

10 9 8 7 6 5 4 3 2 1

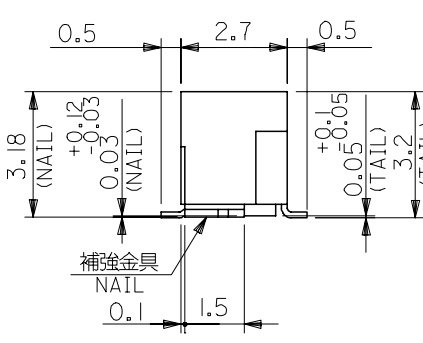
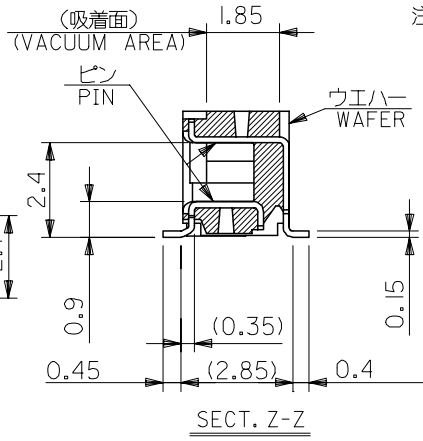
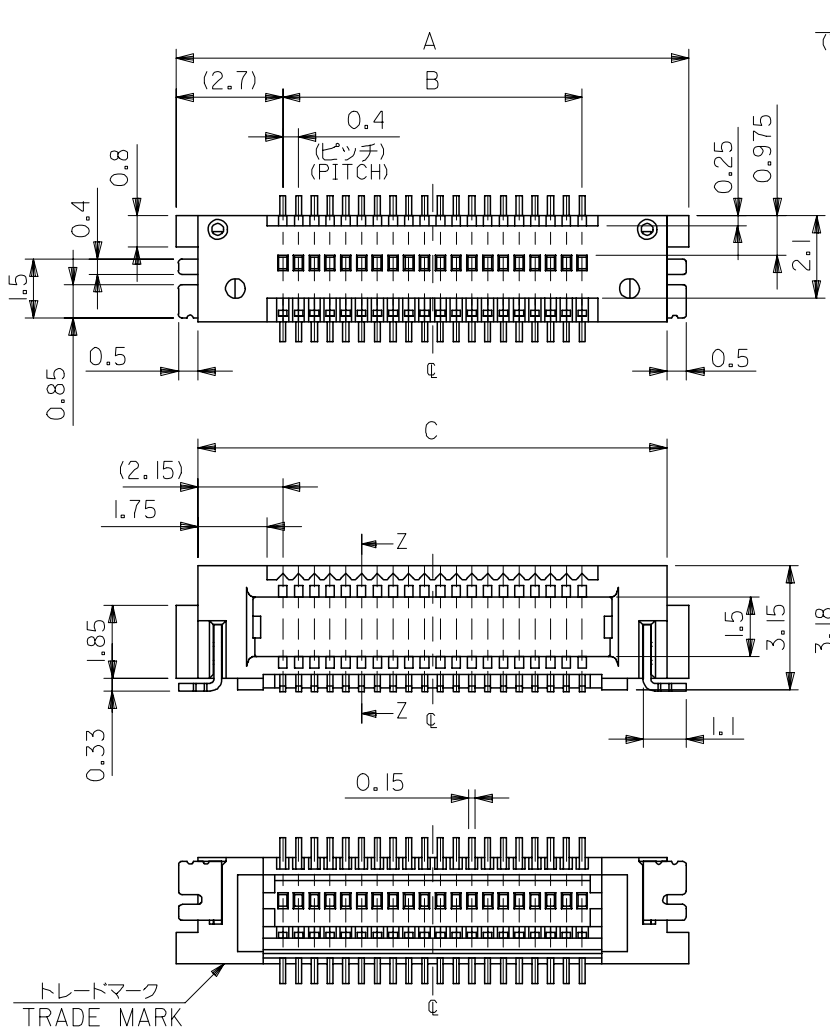

注記 NOTES:

1. 使用材料 MATERIAL
 ウエハー: 液晶ポリマー ガラス充填 UL94V-0 茶色
 WAFER: LIQUID CRYSTAL POLYMER, GLASS FILLED, UL94V-0, COLOR BROWN
 PIN: リン青銅 (t=0.15)
 PIN: PHOSPHOR BRONZE (t=0.15)
 補強金具: リン青銅 (t=0.2)
 FITTING NAIL: PHOSPHOR BRONZE (t=0.2)
2. メッキ仕様 PLATING
 PIN PIN
 金メッキ 0.25 マイクロメートル以上 (コンタクト部)
 GOLD 0.25 MICROMETER MINIMUM (CONTACT AREA)
 金メッキ 0.35 マイクロメートル以下 (テール部)
 GOLD 0.35 MICROMETER MAXIMUM (TAIL AREA)
 下地メッキ: ニッケルメッキ 1.5 マイクロメートル以上
 UNDER PLATING: NICKEL 1.5 MICROMETER MINIMUM
 補強金具 FITTING NAIL
 鍍メッキ: 1.0 マイクロメートル以上
 TIN: 1.0 MICROMETER MINIMUM
 下地メッキ: ニッケルメッキ 1.0 マイクロメートル以上
 UNDER PLATING: NICKEL 1.0 MICROMETER MINIMUM
3. 嵌合相手: 54552 シリーズ
 MATE WITH: 54552 SERIES.
4. テール平坦度は、0.08 以下
 テール及び金具の平坦度は、0.1 以下
 TAIL COPLANARITY TO BE 0.08 MAXIMUM
 TAIL AND FITTING NAIL COPLANARITY TO BE 0.1 MAXIMUM
5. 本製品は 55394-***5 の鉛フリー品である。
 THIS PRODUCT IS LEAD FREE OF 55394-***5.

20.5	21.9	17.6	23	55394-0909	90
18.5	19.9	15.6	21	55394-0809	80
10.5	11.9	7.6	13	55394-0409	40
8.5	9.9	5.6	11	55394-0309	30
6.5	7.9	3.6	9	55394-0209	20
D	C	B	A	MATERIAL NO.	CIRCUIT

MODEL NO.		55394-***9			
DIMENSION STYLE		SCALE	DESIGN UNITS		THIRD ANGLE PROJECTION
MM ONLY		---	METRIC		
DRAWN BY		DATE		TITLE	
HKAWABAT		2004/05/06		0.4 B/B CONN. PLUG ASS'Y (R/A) W/O BOSS -LEAD FREE-	
CHECKED BY		DATE		MOLEX MOLEX INCORPORATED	
KT0JO		2004/05/06			
APPROVED BY		DATE		DOCUMENT NO.	
MSASAO		2004/05/06		SD-55394-015	
MATERIAL NO.		SEE CHART			SHEET NO.
					1 OF 3

REVISED EC NO: J2006-1654 DRW: HVAJIMA 2005/12/27 CHKD: TANAKA 2006/01/05 APPR: NUKITA 2006/01/10	GENERAL TOLERANCES (UNLESS SPECIFIED)	
	10 UNDER	±0.2
	10 OVER 30 UNDER	±0.25
	30 OVER	±0.3
	ANGULAR	±3 °
REV	DRAFT WHERE APPLICABLE MUST REMAIN WITHIN DIMENSIONS	

トレードマーク TRADE MARK

10 9 8 7 6 5 4 3 2 1

F

F

E

E

D

D

C

C

B

B

A

A

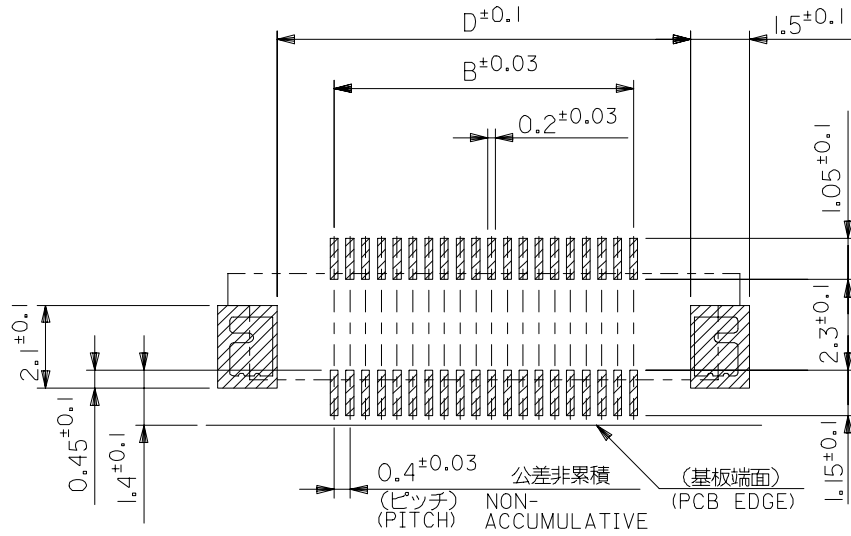

参考基板レイアウト (マウント面)
RECOMMENDED P.C.BOARD
PATTERN DIMENSION. (REFERENCE)
(MOUNTING AREA)

MODEL NO. 55394-***9

REVISED EC NO: J2006-1654 DRW:HYAJIMA 2005/12/27 CHKD:TANAKA 2006/01/05 APPR:NUKITA 2006/01/10	GENERAL TOLERANCES (UNLESS SPECIFIED)		DIMENSION STYLE MM ONLY		SCALE ---	DESIGN UNITS METRIC	THIRD ANGLE PROJECTION	
	10 UNDER	±0.2	DRAWN BY HKAWABAT	DATE 2004/05/06	TITLE 0.4 B/B CONN.PLUG ASS'Y (R/A) W/O BOSS -LEAD FREE-			
	10 OVER 30 UNDER	±0.25	CHECKED BY KTOJO	DATE 2004/05/06	APPROVED BY MSASAO 2004/05/06			
	30 OVER	±0.3	MATERIAL NO.		DOCUMENT NO.		SHEET NO.	
	ANGULAR ±3 °	DRAFT WHERE APPLICABLE MUST REMAIN WITHIN DIMENSIONS		SEE CHART		SD-55394-015		2 OF 3

9

8

7

6

5

4

3

2

10 9 8 7 6 5 4 3 2 1

F

F

E

E

D

D

C

C

B

B

A

A

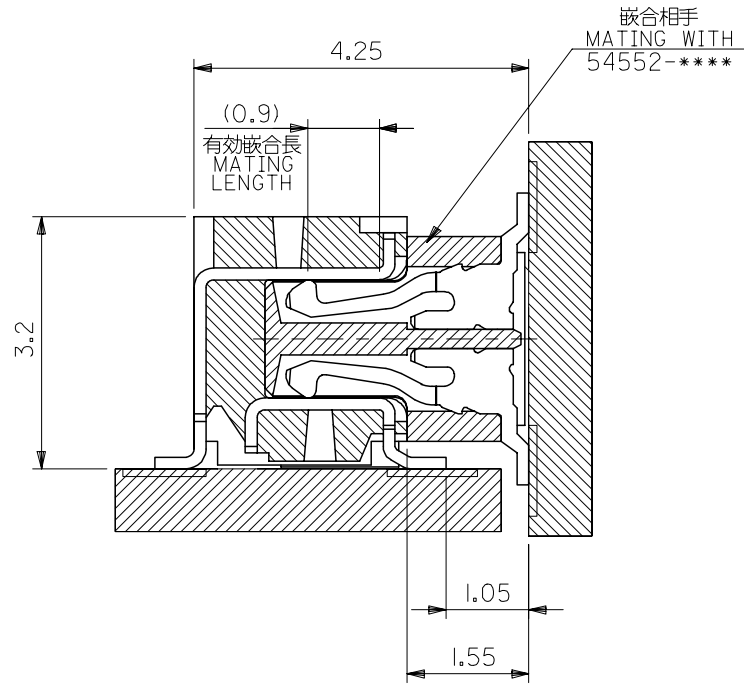

嵌合断面図 (参考)
MATED DRAWING (REFERENCE)

MODEL NO. 55394-****9

REVISED EC NO: J2006-1654 DRW:HYAJIMA 2005/12/27 CHK:D:TANAKA 2006/01/05 APPR:NUKITA 2006/01/10	GENERAL TOLERANCES (UNLESS SPECIFIED)		DIMENSION STYLE MM ONLY		SCALE ---	DESIGN UNITS METRIC	THIRD ANGLE PROJECTION	
	10 UNDER	±0.2	DRAWN BY HKAWABAT	DATE 2004/05/06	TITLE 0.4 B/B CONN.PLUG ASS'Y (R/A) W/O BOSS -LEAD FREE-			
	10 OVER 30 UNDER	±0.25	CHECKED BY KTOJO	DATE 2004/05/06				
	30 OVER	±0.3	APPROVED BY MSASAO	DATE 2004/05/06	MOLEX INCORPORATED			
	ANGULAR	±3 °	MATERIAL NO. SEE CHART					
DRAFT WHERE APPLICABLE MUST REMAIN WITHIN DIMENSIONS		SIZE A3		THIS DRAWING CONTAINS INFORMATION THAT IS PROPRIETARY TO MOLEX INCORPORATED AND SHOULD NOT BE USED WITHOUT WRITTEN PERMISSION				