

ALLOW EXTRA SPACE  
4.00 MM PER SIDE  
(REQUIRED FOR RE-WORK PER AS-46436-100)

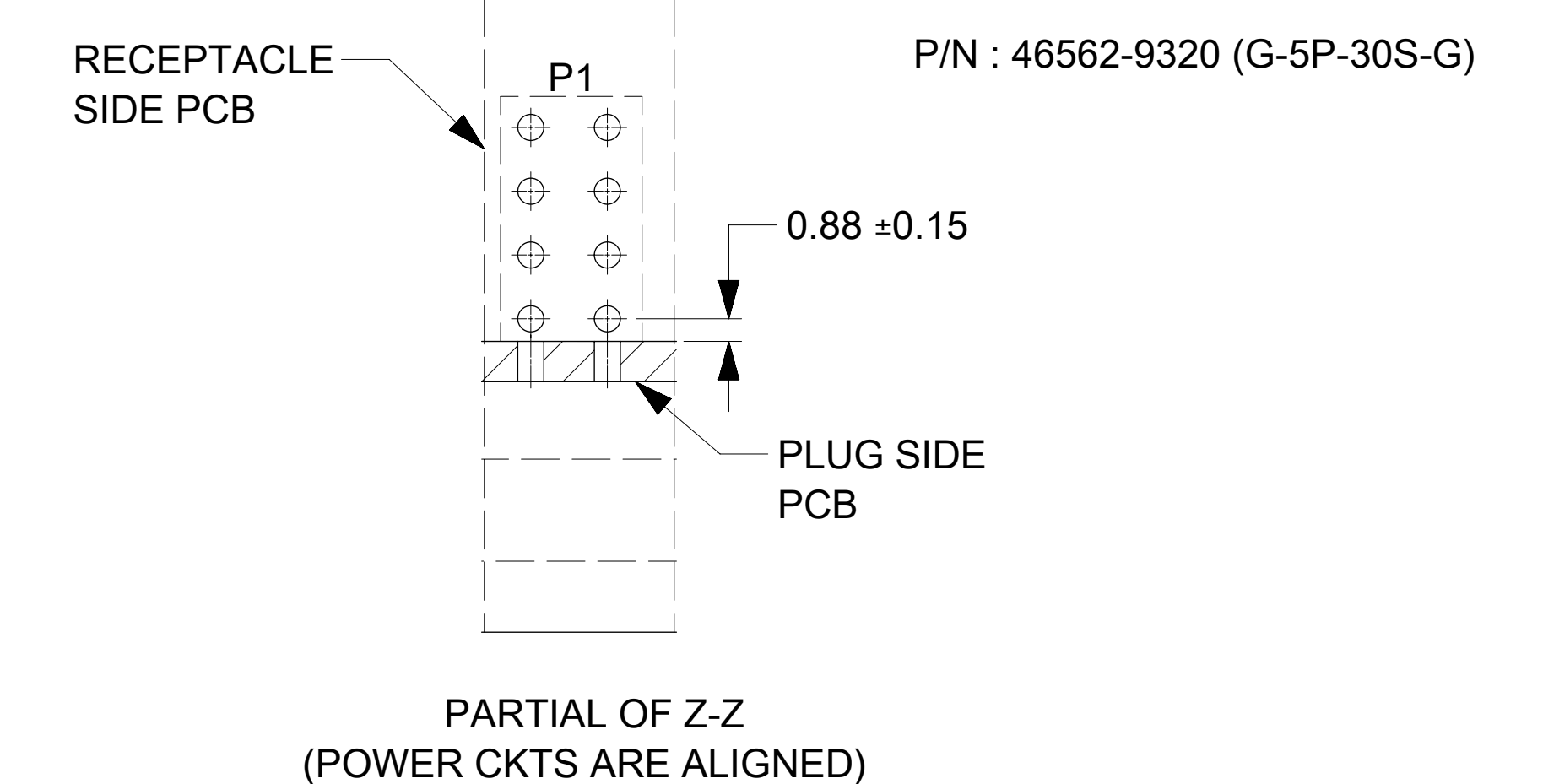

- NOTES:
- MATERIAL:
    - HOUSINGS: LCP UL94, V-0, COLOR: BLACK
    - TERMINALS: HIGH CONDUCTIVITY COPPER ALLOY
    - PLATING: 1.27 MICROMETER (50 MICROINCH) NICKEL OVERALL WITH 2.54 MICROMETER (100 MICROINCH) SELECTIVE TIN ON TAILS AND 0.762 MICROMETER (30 MICROINCH) SELECTIVE GOLD ON CONTACT AREA
  - PACKAGING: ASSEMBLIES TO BE TRAY PACKED PER PACKAGING SPEC: 465621001-PK
  - PLATED THRU HOLE SIZE, REFER TO PS-46436-100 FOR DETAILS
  - PRODUCT SPEC: PS-46436-100
  - APPLICATION SPEC: AS-46436-100
  - PRODUCT TO MEET RoHS REQUIREMENTS
  - ASSEMBLY MATES TO MOLEX PLUG ASSEMBLY P/N 46437-\*\*\*\* (SEE TABLE IN SHEET 2).
  - TAIL DESIGN: COMPLIANT PINS
  - POWER AND SIGNAL CONTACTS ARE LUBRICATED.
  - MOLEX LOGO TO BE LOCATED APPROXIMATELY AS SHOWN.
  - FOR USE WITH 2-32 TYPE AB SELF THREADING SCREWS, SCREW LENGTH OF 9.50MM IS RECOMMENDED FOR 1.58MM THICK PCB MAX TORQUE IS 4 LBS-IN.

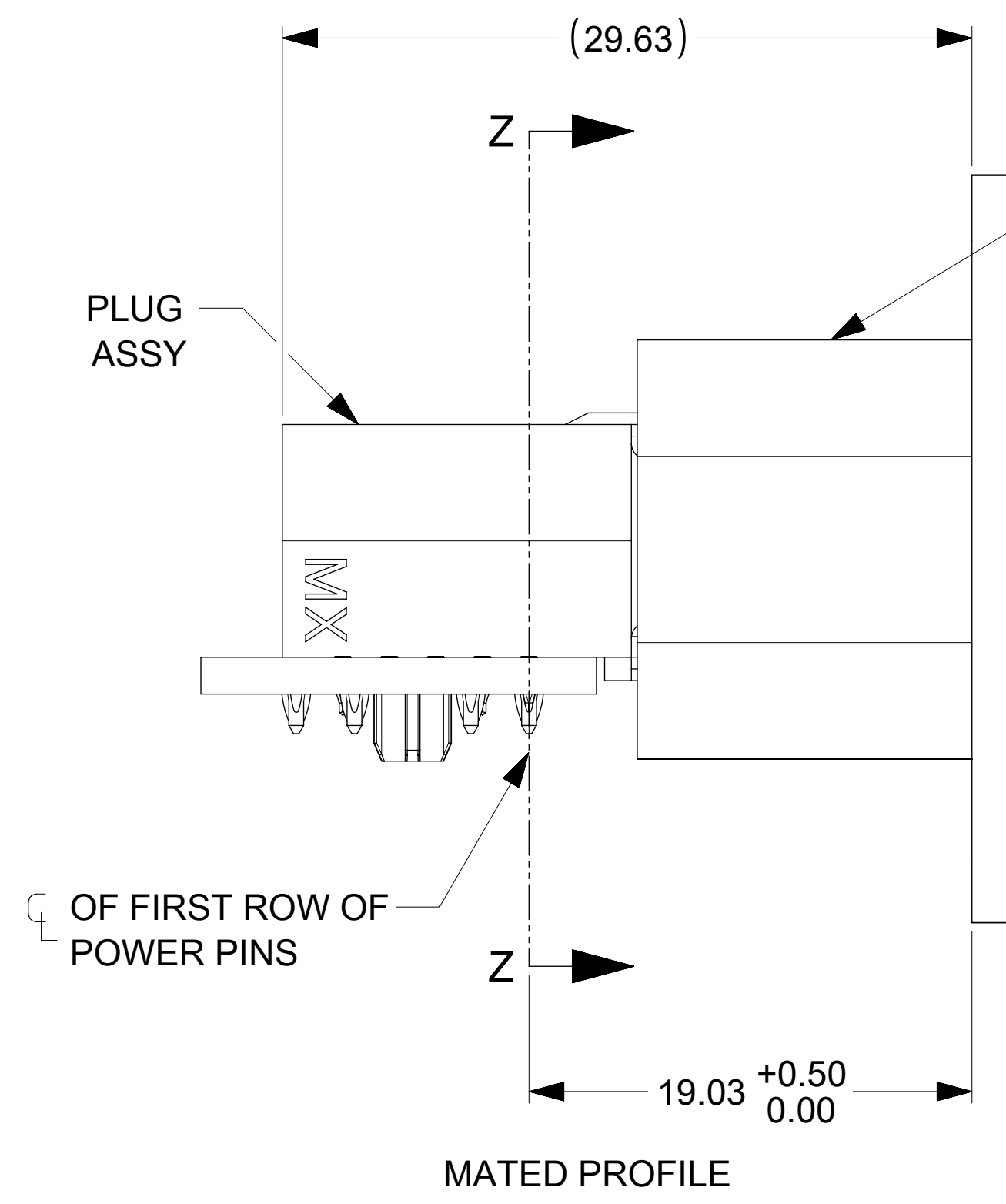
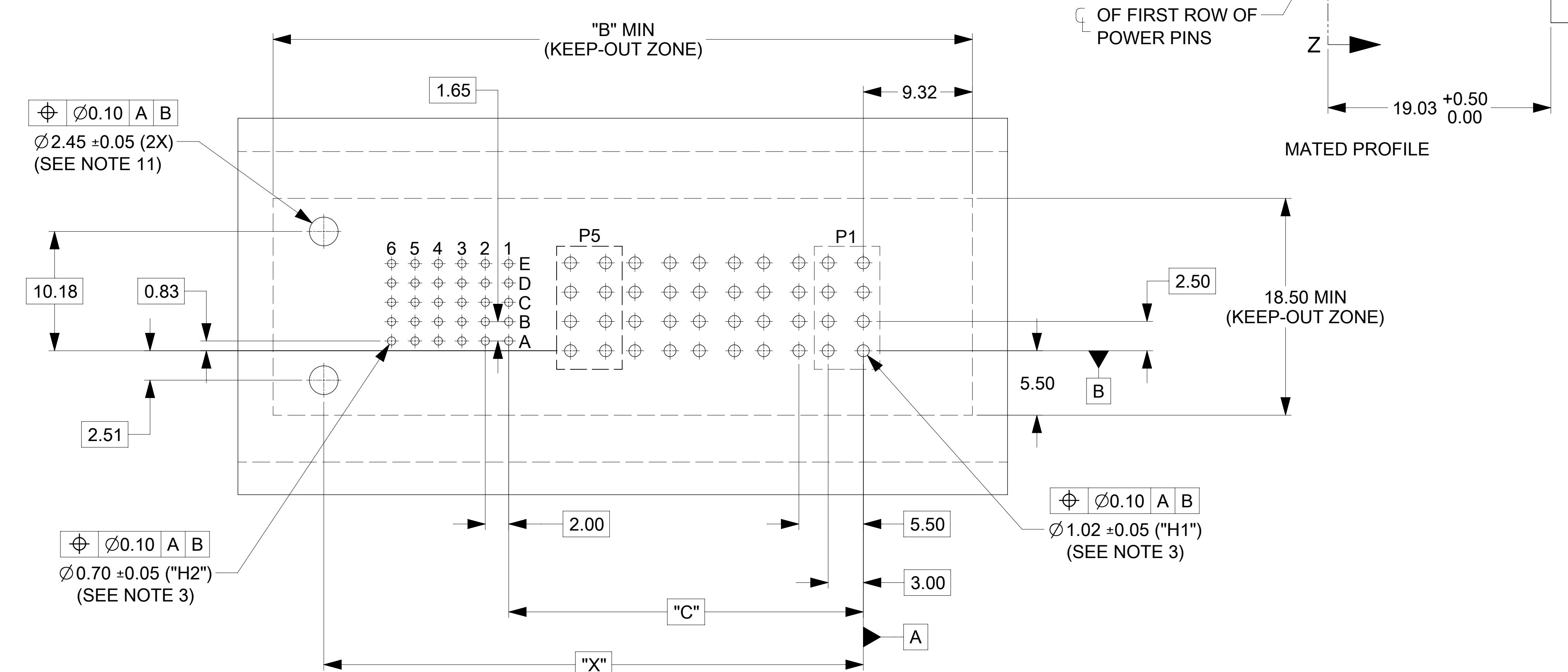

|   |  |                        |  |   |  |              |  |                 |  |
|---|--|------------------------|--|---|--|--------------|--|-----------------|--|
| THIS DRAWING CONTAINS INFORMATION THAT IS PROPRIETARY TO MOLEX ELECTRONIC TECHNOLOGIES, LLC AND SHOULD NOT BE USED WITHOUT WRITTEN PERMISSION |  |                        |  |   |  |              |  |                 |  |
| DIMENSION UNITS   |  | SCALE                  |  | CURRENT REV DESC: ADDED ISOMETRIC VIEWS |  |              |  |                 |  |
| mm  |  | 4:1                    |  |   |  |              |  |                 |  |
| GENERAL TOLERANCES (UNLESS SPECIFIED)   |  |                        |  |   |  |              |  |                 |  |
| ANGULAR TOL ± 0.5°  |  |                        |  |   |  |              |  |                 |  |
| 4 PLACES ±  |  | EC NO: 689821          |  |   |  |              |  |                 |  |
| 3 PLACES ±  |  | DRWN: HARSHG           |  | 2021/12/13                              |  |              |  |                 |  |
| 2 PLACES ± 0.13   |  | CHK'D: GJEEVANSURES    |  | 2021/12/22                              |  |              |  |                 |  |
| 1 PLACE ± 0.25  |  | APPR: HTHYAGARAJ       |  | 2022/02/14                              |  |              |  |                 |  |
| 0 PLACES ±  |  | INITIAL REVISION:      |  |   |  |              |  |                 |  |
|   |  | DRWN: KSUTAR           |  | 2021/08/16                              |  |              |  |                 |  |
|   |  | APPR: HTHYAGARAJ       |  | 2021/10/21                              |  |              |  |                 |  |
| DRAFT WHERE APPLICABLE MUST REMAIN WITHIN DIMENSIONS  |  | THIRD ANGLE PROJECTION |  | DRAWING                                 |  | SERIES       |  | MATERIAL NUMBER |  |
|   |  | D-SIZE                 |  | 46562                                   |  | SEE TABLE    |  | CUSTOMER        |  |
|   |  |                        |  | GENERAL MARKET                          |  | SHEET NUMBER |  | 1 OF 4          |  |

|                 |    |              |            |          |
|-----------------|----|--------------|------------|----------|
| DOCUMENT STATUS | P1 | RELEASE DATE | 2022/02/14 | 09:02:11 |
|-----------------|----|--------------|------------|----------|

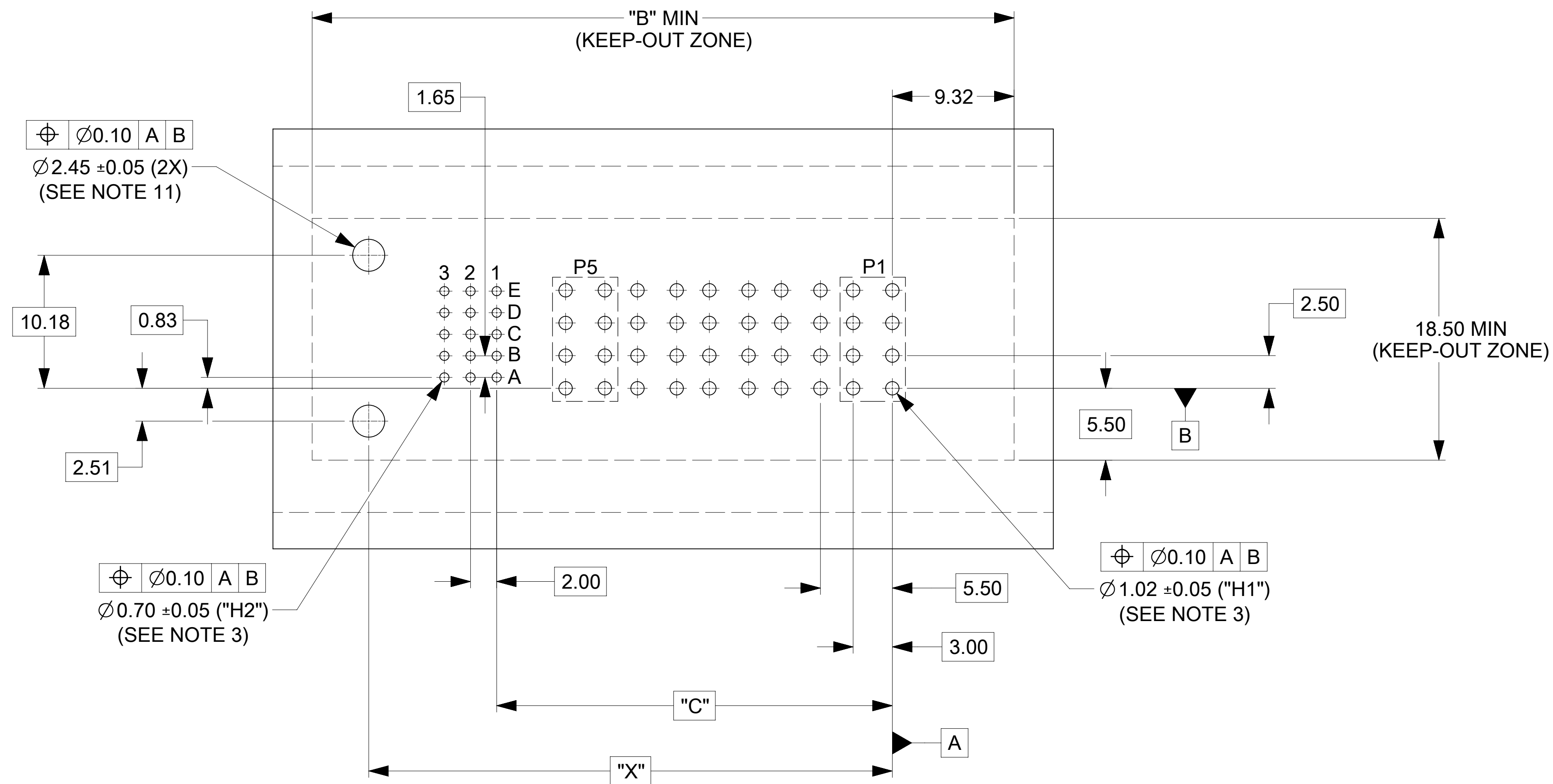

RECOMMENDED PCB LAYOUT AND KEEP-OUT ZONE FOR G-(1P TO 5P)-15S-G

REFER TO BELOW TABLE FOR DIMENSIONS.

| FG P/N    | CONFIGURATION | POWER CKT SIZE | SIGNAL CKT SIZE | DIM "A" (IN MM) | DIM "B" (IN MM) | DIM "C" (IN MM) | DIM "X" (IN MM) | HOLES COUNT "H1" | HOLES COUNT "H2" | MATES WITH R/A PLUG ASSY P/N |
|-----------|---------------|----------------|-----------------|-----------------|-----------------|-----------------|-----------------|------------------|------------------|------------------------------|
| 465629311 | G-1P-15S-G    | 1              | 15              | 30.71           | 31.71           | 8.28            | 18.06           | 08               | 15               | 464379311                    |
| 465629312 | G-2P-15S-G    | 2              | 15              | 36.21           | 37.21           | 13.78           | 23.56           | 16               | 15               | 464379312                    |
| 465629313 | G-3P-15S-G    | 3              | 15              | 41.71           | 42.71           | 19.28           | 29.06           | 24               | 15               | 464379313                    |
| 465629314 | G-4P-15S-G    | 4              | 15              | 47.21           | 48.21           | 24.78           | 34.56           | 32               | 15               | 464379314                    |
| 465629315 | G-5P-15S-G    | 5              | 15              | 52.71           | 53.71           | 30.28           | 40.06           | 40               | 15               | 464379315                    |
| 465629316 | G-1P-30S-G    | 1              | 30              | 36.71           | 37.71           | 8.28            | 24.06           | 08               | 30               | 464379316                    |
| 465629317 | G-2P-30S-G    | 2              | 30              | 42.21           | 43.21           | 13.78           | 29.56           | 16               | 30               | 464379317                    |
| 465629318 | G-3P-30S-G    | 3              | 30              | 47.71           | 48.71           | 19.28           | 35.06           | 24               | 30               | 464379318                    |
| 465629319 | G-4P-30S-G    | 4              | 30              | 53.21           | 54.21           | 24.78           | 40.56           | 32               | 30               | 464379319                    |
| 465629320 | G-5P-30S-G    | 5              | 30              | 58.71           | 59.71           | 30.28           | 46.06           | 40               | 30               | 464379320                    |

THIS DRAWING CONTAINS INFORMATION THAT IS PROPRIETARY TO MOLEX ELECTRONIC TECHNOLOGIES, LLC AND SHOULD NOT BE USED WITHOUT WRITTEN PERMISSION

|  |                     |   |  |                |              |           |
|--|---------------------|---|--|----------------|--------------|-----------|
| DIMENSION UNITS<br><b>mm</b>                         | SCALE<br><b>4:1</b> | CURRENT REV DESC: ADDED ISOMETRIC VIEWS |  |                |              |           |
| GENERAL TOLERANCES (UNLESS SPECIFIED)                |                     |   |  |                |              |           |
| ANGULAR TOL  | ± 0.5°              | EC NO: 689821                           | <b>G-*P-*S-G</b><br>VERT RECEP ASSY - TEN60 POWER FAMILY |                |              |           |
| 4 PLACES   | ±                   | DRWN: HARSHG 2021/12/13                 |  |                |              |           |
| 3 PLACES   | ±                   | CHK'D: GJEEVANSURES 2021/12/22          | PRODUCT CUSTOMER DRAWING                                 |                |              |           |
| 2 PLACES   | ± 0.13              | APPR: HTHYAGARAJ 2022/02/14             |  |                |              |           |
| 1 PLACE  | ± 0.25              | INITIAL REVISION:                       | DOCUMENT NUMBER  | DOC TYPE       | DOC PART     | REVISION  |
| 0 PLACES   | ±                   | DRWN: KSUTAR 2021/08/16                 | <b>465629320</b>   | PSD            | 000          | <b>A1</b> |
| DRAFT WHERE APPLICABLE MUST REMAIN WITHIN DIMENSIONS |                     | APPR: HTHYAGARAJ 2021/10/21             | MATERIAL NUMBER  | CUSTOMER       | SHEET NUMBER |           |
| THIRD ANGLE PROJECTION                               |                     | DRAWING                                 | SEE TABLE  | GENERAL MARKET | 2 OF 4       |           |
| D-SIZE   |                     | SERIES                                  |  |                |              |           |
|  |                     | <b>46562</b>                            |  |                |              |           |

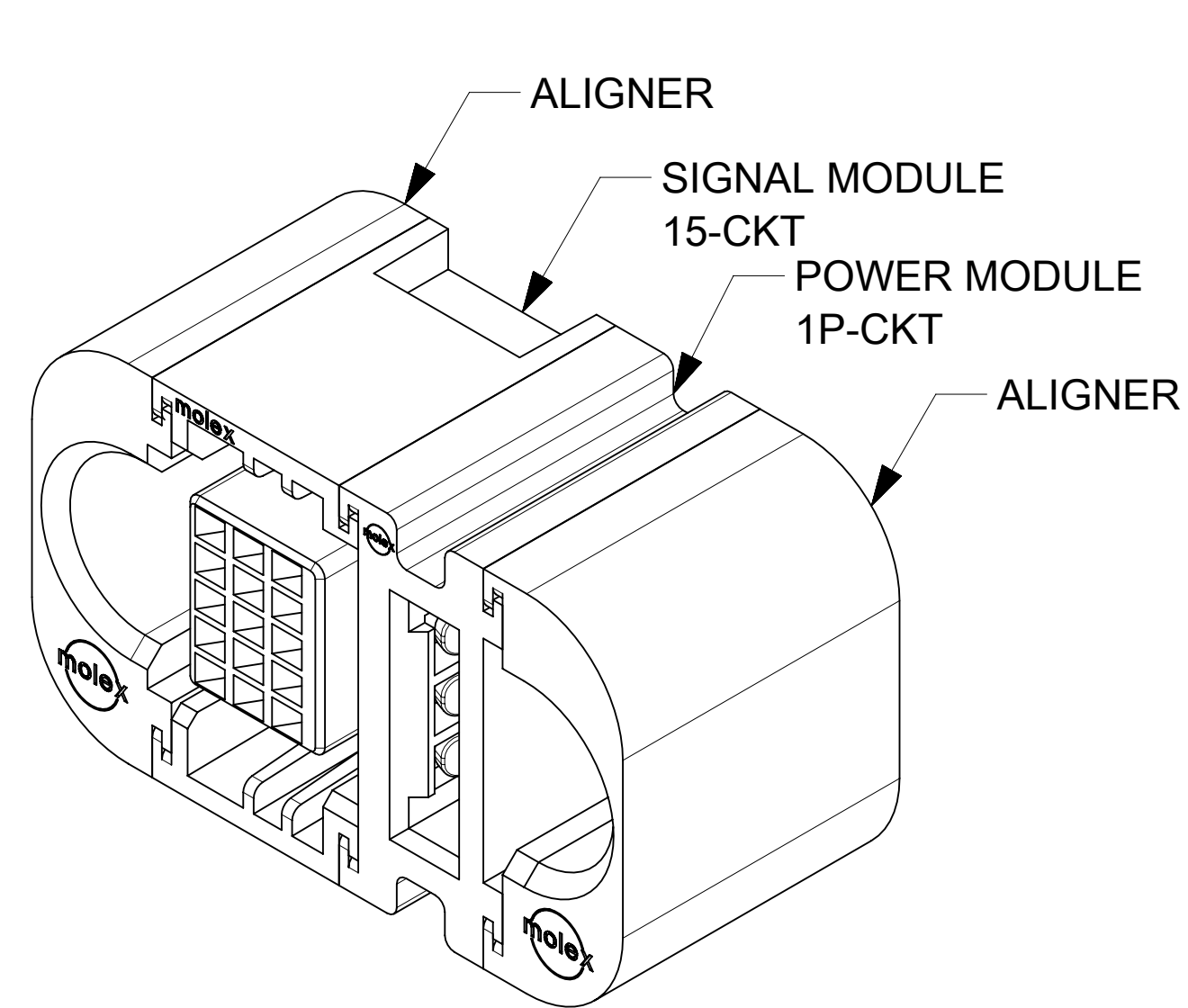

P/N : 46562-9311 (G-1P-15S-G)

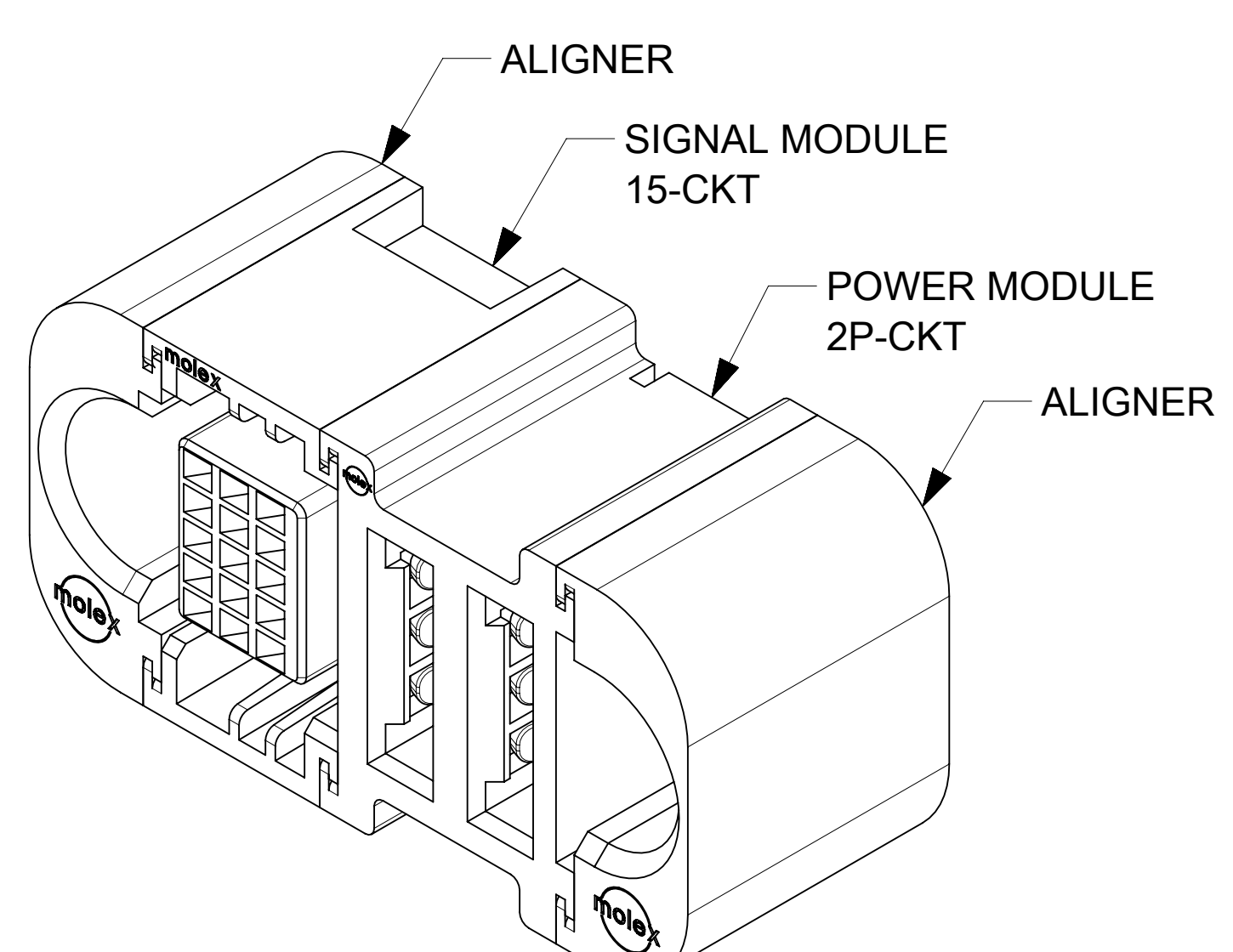

P/N : 46562-9312 (G-2P-15S-G)

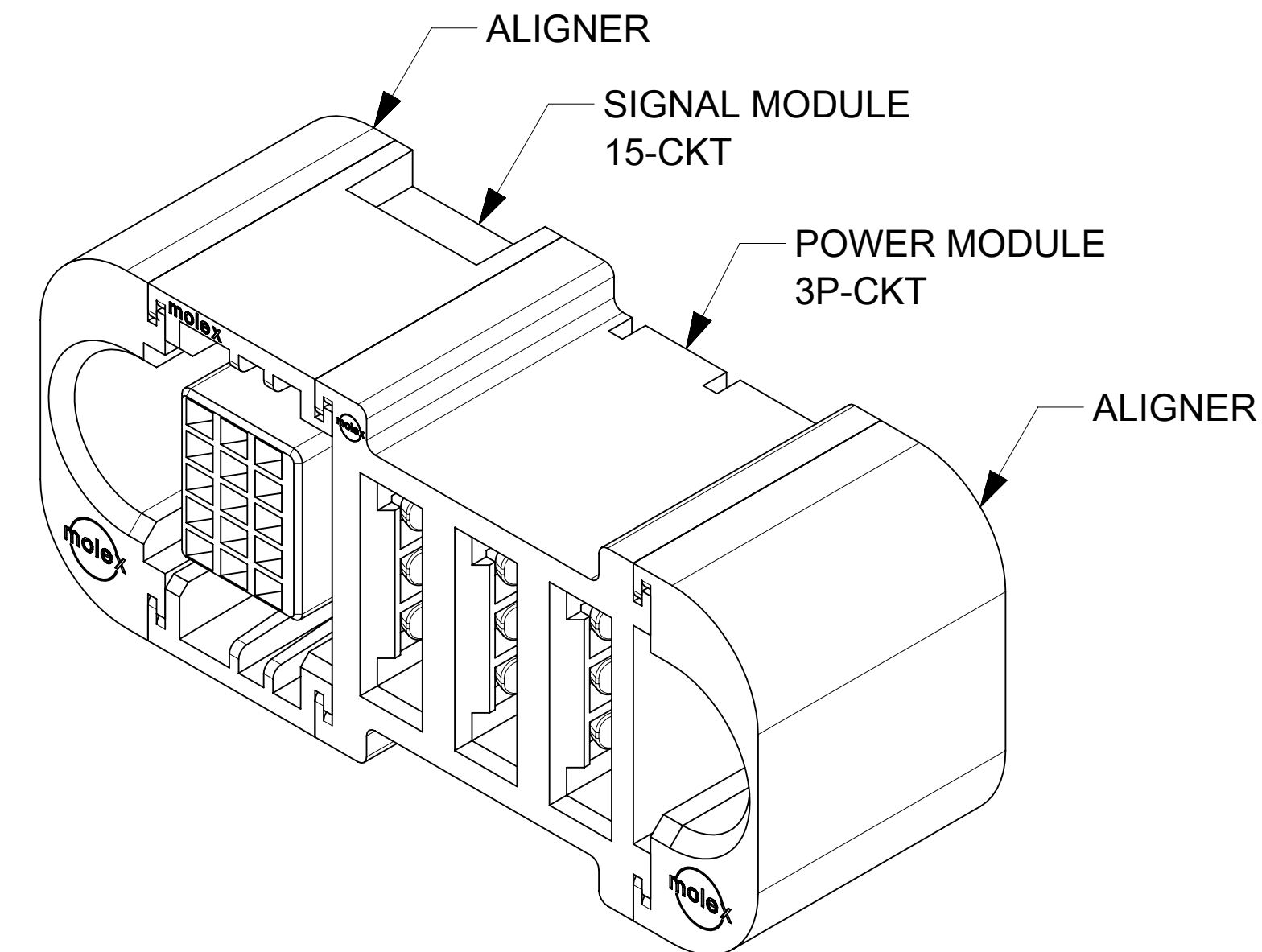

P/N : 46562-9313 (G-3P-15S-G)

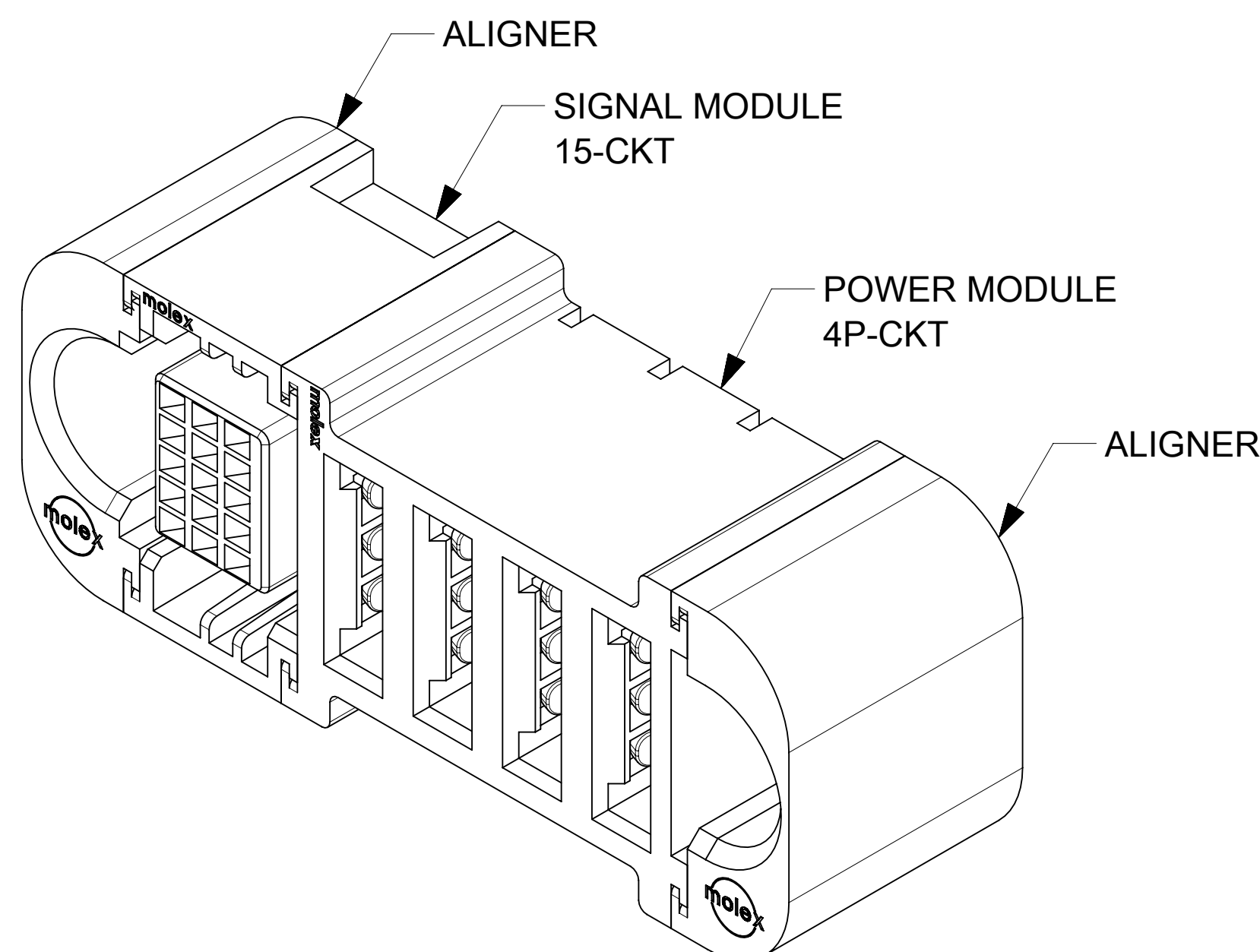

P/N : 46562-9314 (G-4P-15S-G)

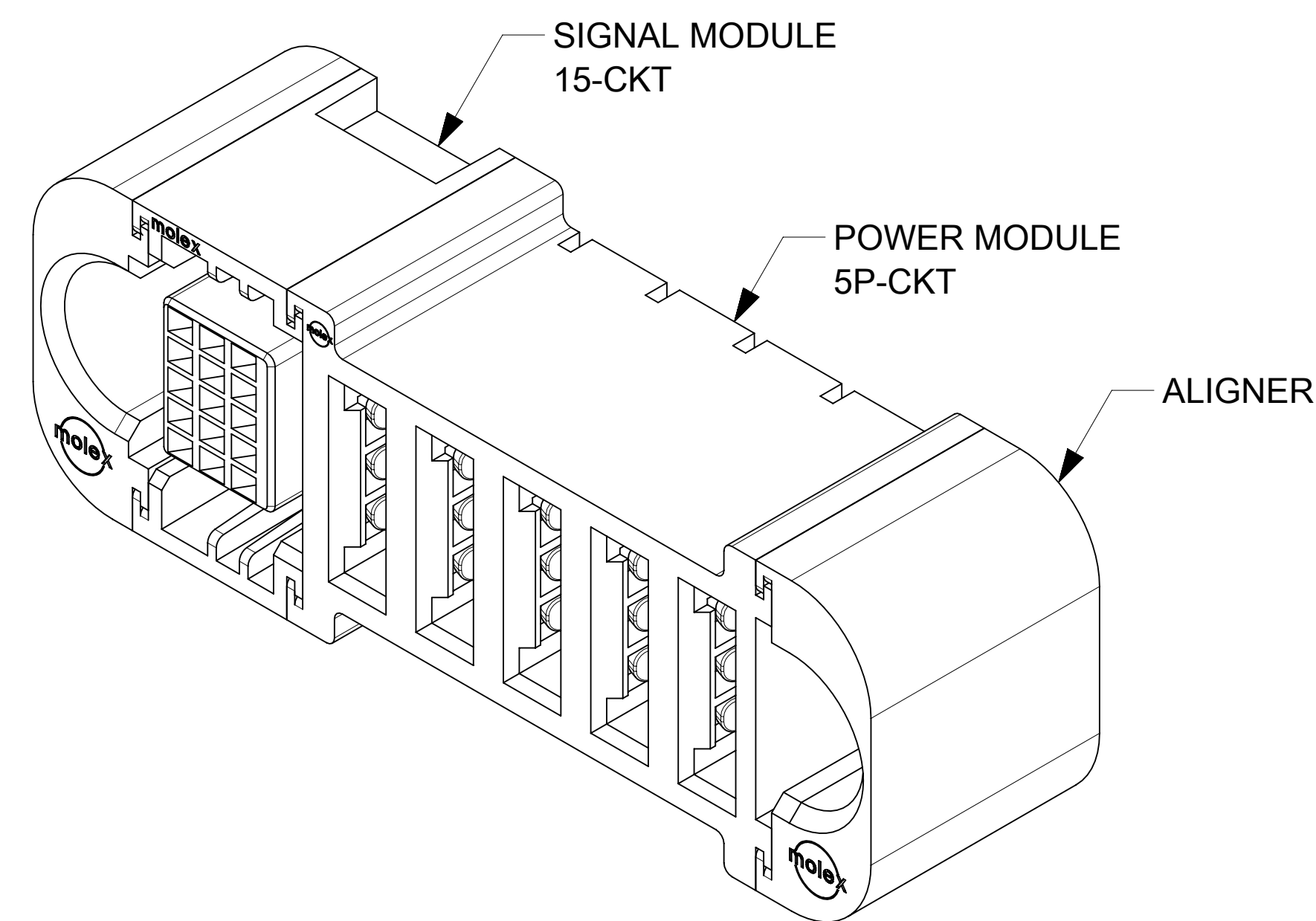

P/N : 46562-9315 (G-5P-15S-G)

|   |  |       |  |   |  |            |  |  |  |           |          |                |
|---|--|-------|--|---|--|------------|--|--|--|-----------|----------|----------------|
| THIS DRAWING CONTAINS INFORMATION THAT IS PROPRIETARY TO MOLEX ELECTRONIC TECHNOLOGIES, LLC AND SHOULD NOT BE USED WITHOUT WRITTEN PERMISSION |  |       |  |   |  |            |  |  |  |           |          |                |
| DIMENSION UNITS   |  | SCALE |  | CURRENT REV DESC: ADDED ISOMETRIC VIEWS |  |            |  |  |  |           |          |                |
| mm  |  | 4:1   |  |   |  |            |  |  |  |           |          |                |
| GENERAL TOLERANCES (UNLESS SPECIFIED)   |  |       |  | EC NO: 689821                           |  |            |  |  |  |           |          |                |
| ANGULAR TOL ± 0.5°  |  |       |  | DRWN: HARSHG                            |  | 2021/12/13 |  | <b>G-*P-*S-G</b><br>VERT RECEP ASSY - TEN60 POWER FAMILY |  |           |          |                |
| 4 PLACES ±  |  |       |  | CHK'D: GJEEVANSURES                     |  | 2021/12/22 |  |  |  |           |          |                |
| 3 PLACES ±  |  |       |  | APPR: HTHYAGARAJ                        |  | 2022/02/14 |  | PRODUCT CUSTOMER DRAWING                                 |  |           |          |                |
| 2 PLACES ± 0.13   |  |       |  | INITIAL REVISION:                       |  |            |  | DOCUMENT NUMBER  |  | DOC TYPE  | DOC PART | REVISION       |
| 1 PLACE ± 0.25  |  |       |  | DRWN: KSUTAR                            |  | 2021/08/16 |  | 465629320  |  | PSD       | 000      | A1             |
| 0 PLACES ±  |  |       |  | APPR: HTHYAGARAJ                        |  | 2021/10/21 |  | MATERIAL NUMBER  |  | CUSTOMER  |          | SHEET NUMBER   |
| DRAFT WHERE APPLICABLE MUST REMAIN WITHIN DIMENSIONS  |  |       |  | THIRD ANGLE PROJECTION                  |  | DRAWING    |  | SERIES   |  | SEE TABLE |          | GENERAL MARKET |
|   |  |       |  |   |  | D-SIZE     |  | 46562  |  |           |          | 3 OF 4         |

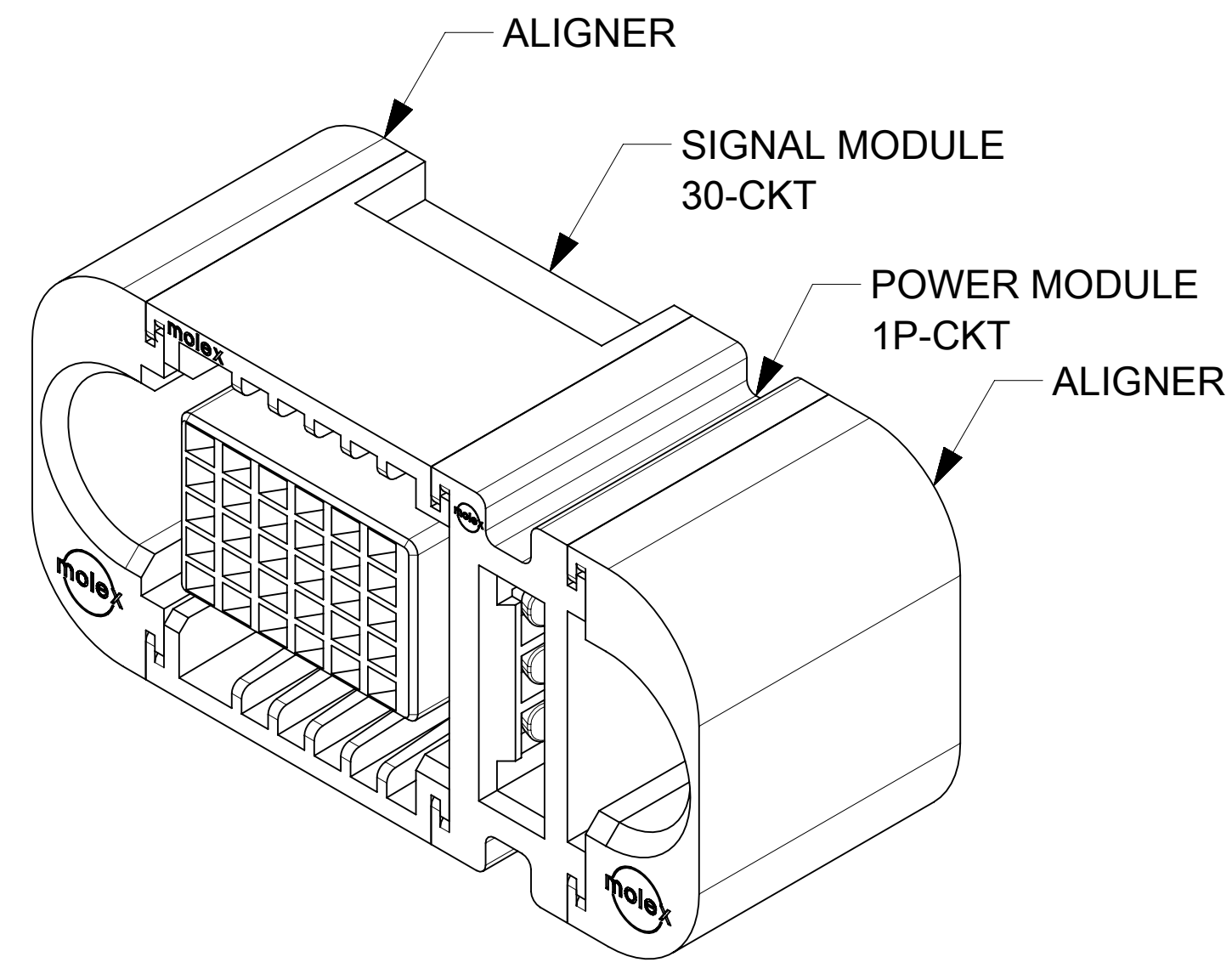

P/N : 46562-9316 (G-1P-30S-G)

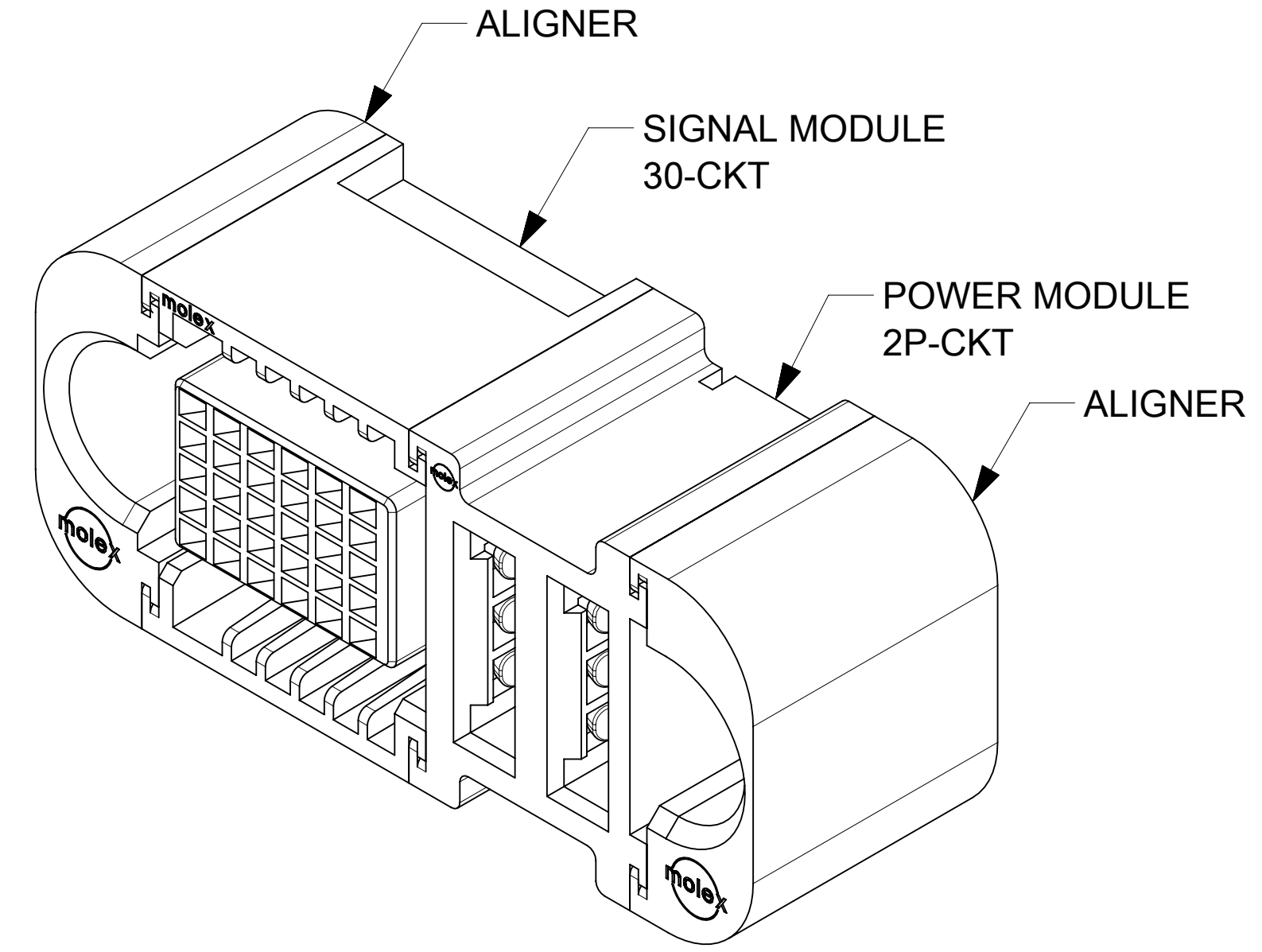

P/N : 46562-9317 (G-2P-30S-G)

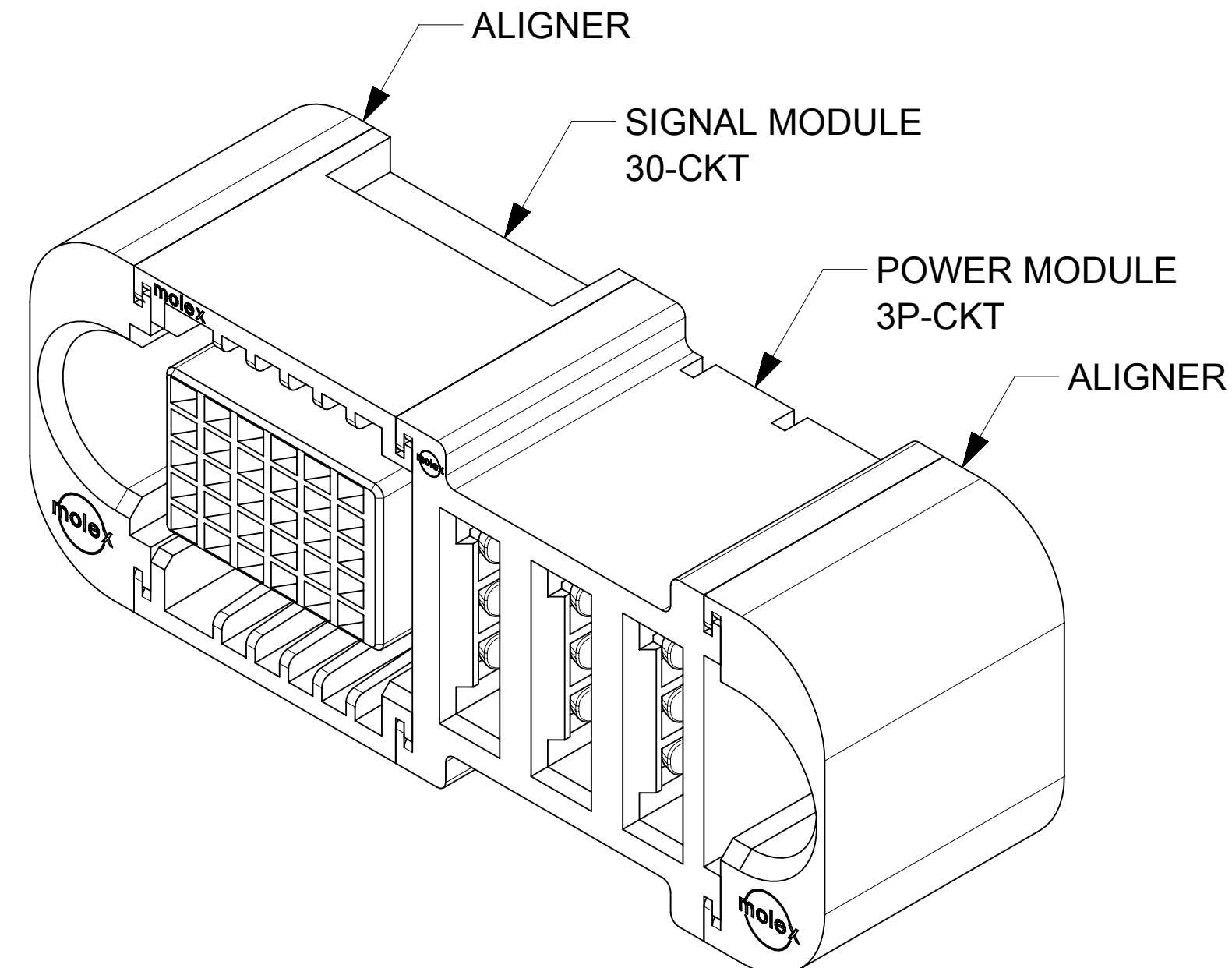

P/N : 46562-9318 (G-3P-30S-G)

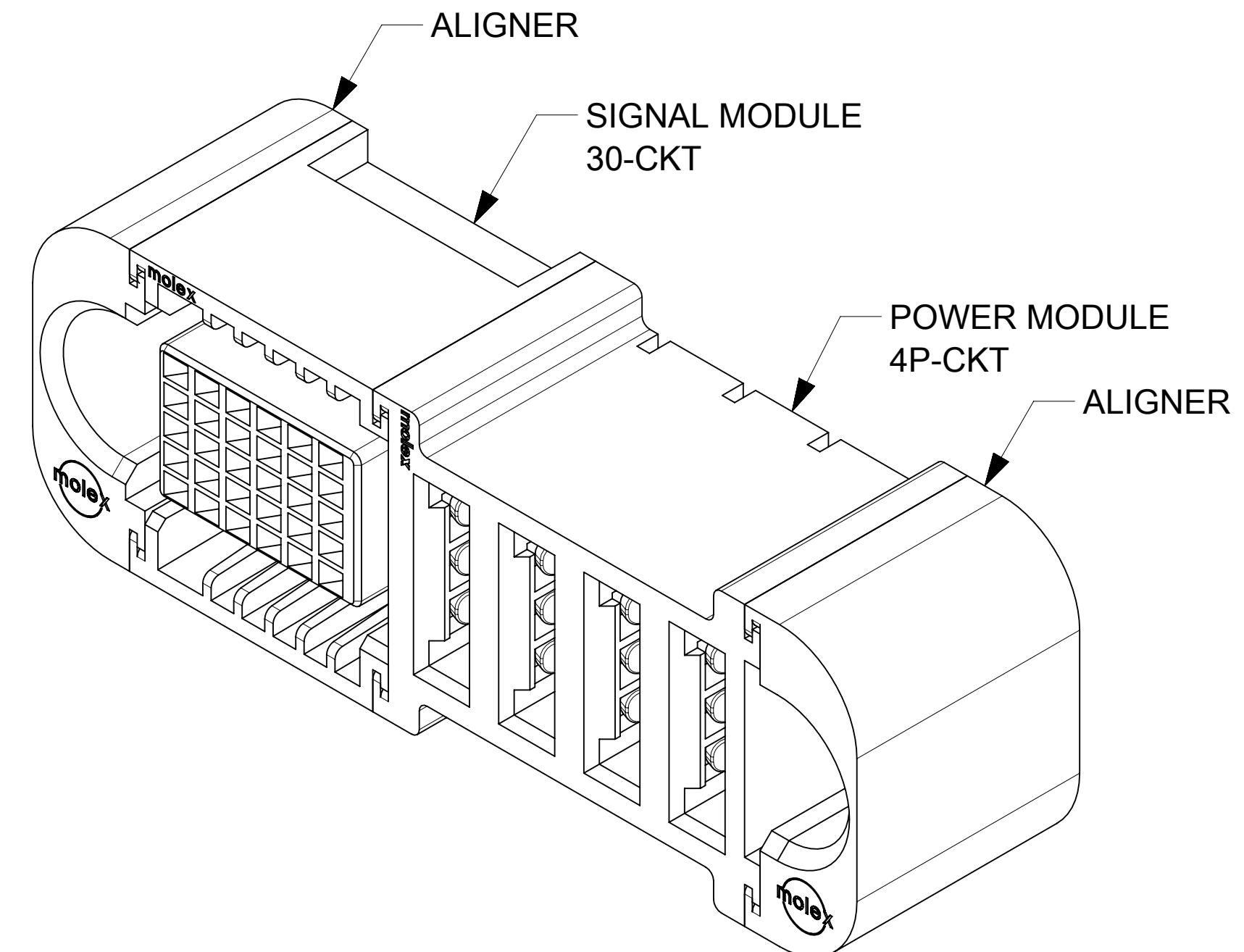

P/N : 46562-9319 (G-4P-30S-G)

|   |  |                        |  |   |  |              |  |  |  |
|---|--|------------------------|--|---|--|--------------|--|--|--|
| THIS DRAWING CONTAINS INFORMATION THAT IS PROPRIETARY TO MOLEX ELECTRONIC TECHNOLOGIES, LLC AND SHOULD NOT BE USED WITHOUT WRITTEN PERMISSION |  |                        |  |   |  |              |  |  |  |
| DIMENSION UNITS   |  | SCALE                  |  | CURRENT REV DESC: ADDED ISOMETRIC VIEWS |  |              |  |  |  |
| mm  |  | 4:1                    |  |   |  |              |  |  |  |
| GENERAL TOLERANCES (UNLESS SPECIFIED)   |  |                        |  |   |  |              |  |  |  |
| ANGULAR TOL   |  | ± 0.5°                 |  |   |  |              |  |  |  |
| 4 PLACES  |  | ±                      |  | EC NO: 689821                           |  |              |  |  |  |
| 3 PLACES  |  | ±                      |  | DRWN: HARSHG                            |  | 2021/12/13   |  |  |  |
| 2 PLACES  |  | ± 0.13                 |  | CHK'D: GJEEVANSURES                     |  | 2021/12/22   |  |  |  |
| 1 PLACE   |  | ± 0.25                 |  | APPR: HTHYAGARAJ                        |  | 2022/02/14   |  |  |  |
| 0 PLACES  |  | ±                      |  | INITIAL REVISION:                       |  |              |  |  |  |
| DRAFT WHERE APPLICABLE  |  | THIRD ANGLE PROJECTION |  | DRWN: KSUTAR                            |  | 2021/08/16   |  |  |  |
| MUST REMAIN WITHIN DIMENSIONS   |  | DRAWING                |  | APPR: HTHYAGARAJ                        |  | 2021/10/21   |  |  |  |
|   |  | D-SIZE                 |  | SERIES                                  |  |              |  |  |  |
|   |  | 46562                  |  | MATERIAL NUMBER                         |  | CUSTOMER     |  |  |  |
|   |  | SEE TABLE              |  | GENERAL MARKET                          |  | SHEET NUMBER |  |  |  |
|   |  | 4 OF 4                 |  |   |  |              |  |  |  |