

1) Die Kräfteinleitung beim Stecken und Ziehen muss entlang der Achse der Kontaktbuchse erfolgen  
*the initiation of the insertion and withdrawal force has to be along the axis of the contact socket*

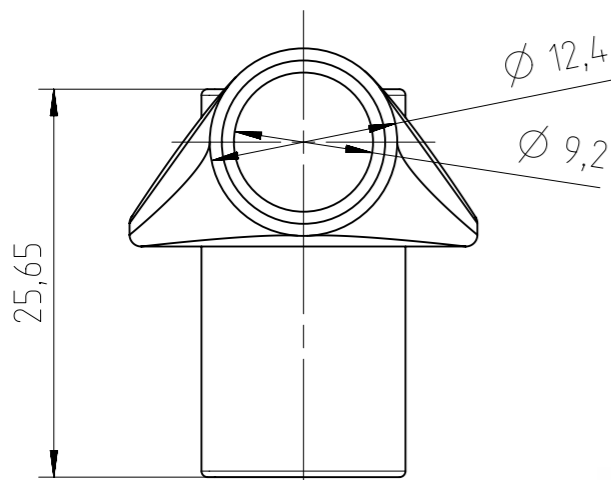

Steckrichtung  
*direction of insertion*

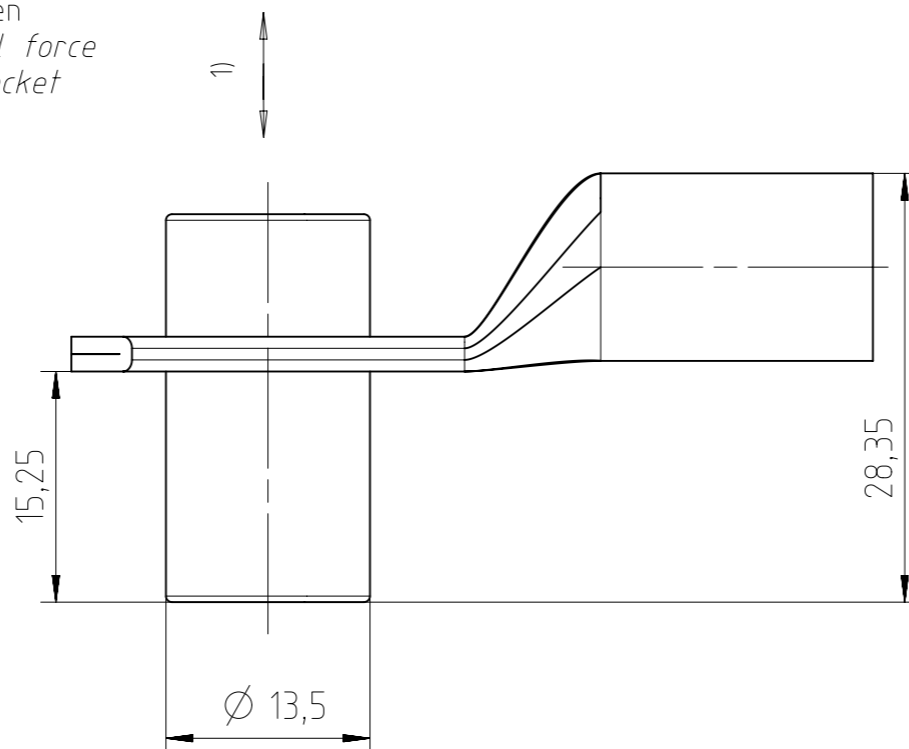

**press|mate**  
 Eine Technologiokooperation von  
**WEITKOWITZ** und **Amphenol**

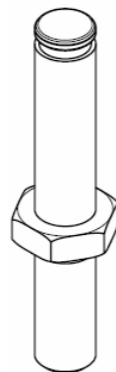

N 01 080 6601 001

<sup>2)</sup> based on tests with mating partner N 01 080 6601 001

Alle technischen Daten wurden unter Laborbedingungen ermittelt und können im Praxisbetrieb abweichen.  
 Es handelt sich bei den Angaben weder um Beschaffenheits- noch um Haltbarkeitsgarantien.  
*All technical data have been measured in a laboratory environment and can be different during practical usage of the product. Any product information is for descriptive usage only and not legally binding; particularly the information does not constitute or provide any legal guarantees ("Beschaffenheitsgarantie" or "Haltbarkeitsgarantie").*

Nominal sizes		
Radsok size	8mm	
cable lug	35mm <sup>2</sup> (13527 from Weitkowitz)	
Material and Surfaces		
Grid	Cu alloy, silver-plated	
cable lug	Cu, tin-plated	
Mechanical Characteristics		
Standard	Value	
Mating and withdrawal force	IEC 60 512-13-2	27 ± 12N
measured with polished steel pin $\varnothing 7,995 +0,001/-0,005$		
Climatic Characteristics		
Standard	Value	
max. operating temperature (incl. self heating)	IEC 60 512-11-9	+150°C
Electric Characteristics		
Standard	Value	
current carrying capacity (@Ta=40°C)	IEC 60 512-5-2	220 A <sup>2)</sup>
empfohlene Crimpwerkzeuge <i>recommended crimp tools</i>		
Hydraulische Akku-Pressen <i>hydraulic battery-press</i>	STIL01 91100 - Weitkowitz	
Presseinsatz WM-Form <i>press insert WM-shape</i>	F-Serie / 35mm <sup>2</sup> 90332 - Weitkowitz	

Gewicht (errechnet) / Calc WT: 38,1 g		Zul. Abw./Tolerances:		Maßstab / Scale: 2:1		A3			
Prüfmaß / Testdimension		ISO 2768-mH		DIN / ISO 13715		CUSTOMER DRAWING			
Teileindex Partindexnumber		Datum/Date		Name		Press-Mate 35mm <sup>2</sup> -Radsok 8.0 crimp socket F-Series			
		Gez. Drawn		18.08.2016		JHÖNN		Inspector: 30.08.2016 MGRIM	
		Status: Released							
		Inspector: 30.08.2016 MGRIM							
		Amphenol-Tuchel Electronics GmbH						Blatt/Sheet 1 1 Bl.	
01		201500516		18.08.2016		JHÖNN		M N 02 080 6151 002	
Index		Änderung/Description		Datum/Date		Name		4.050.363	
								Ers. f. / Replacement for: M-SK 201500516 515	

Copying of this document and giving it to others and the use or communication of the contents thereof, are forbidden without express authority. Offenders are liable to the payment of damages. All rights are reserved in the event of the grant of a patent or the registration of the utility model or design.

Weitergabe sowie Vervielfältigung dieser Unterlage, Verwertung und Mitteilung ihres Inhalts nicht gestattet, soweit nicht ausdrücklich zugestanden. Zuwiderhandlungen verpflichten zu Schadensersatz. Alle Rechte für den Fall der Patenterteilung oder Gebrauchsmuster-Ertragung vorbehalten.