

BAS2 | Bipod supports

Technopolymer



- 1
- 2
- 3
- 4
- 5
- 6
- 7
- 8
- 9
- 10
- 11
- 12
- 13
- 14
- 15
- 16
- 17
- 18

MATERIAL

Glass-fibre reinforced polyamide based (PA) technopolymer, black colour, matte finish.

STANDARD EXECUTIONS

- **BAS2-A**: zinc-plated steel M10 screws, nuts and washers.
- **BAS2-SST**: AISI 304 stainless steel M10 screws, nuts and washers.

ASSEMBLY ON LEVELLING ELEMENTS

The bipod support bases are supplied with brass bosses, threaded pass-through hole for the assembly of the levelling element series LS.A (see page 1224), LV.A (see page 1238), LV.F (see page 1258).

FEATURES

The absence of cavities and the slightly round shapes offer modern and elegant aesthetics and guarantee the easy cleaning. Maximum tightening torque for screw assembly 35 Nm.

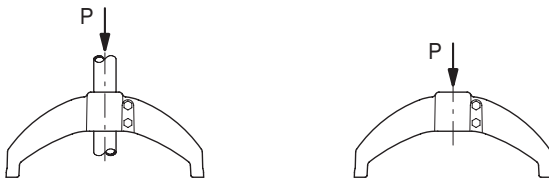

Retention force
P = 2000 N

Max. static load
P = 9800 N

Values obtained with tightening torque 35 Nm

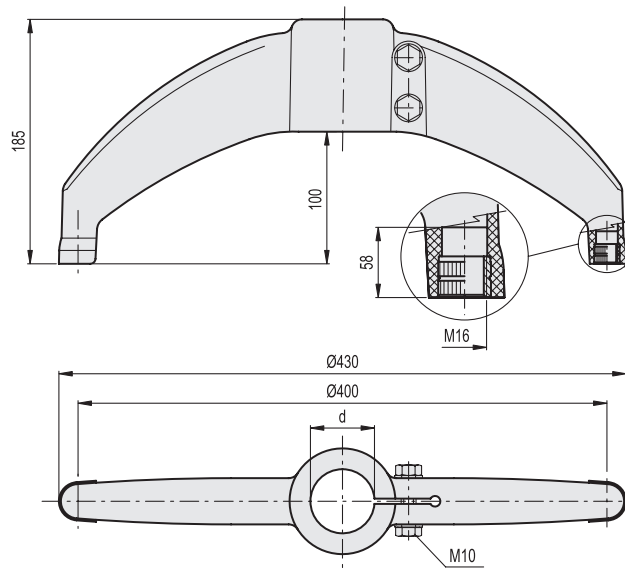

Conversion Table	
1 mm = 0,039 inch	
d	
mm	inch
42.4	1.67
48.3	1.90
60.3	2.37

BAS2-A

Code	Description	d Tube (mm)	d Tube (GAS)	Δ
419636	BAS2-42-A	42.4	1"1/4	680
419634	BAS2-48-A	48.3	1"1/2	670
419632	BAS2-60-A	60.3	2"	650

METRIC

BAS2-SST

Code	Description
419637	BAS2-42-SST
419635	BAS2-48-SST
419633	BAS2-60-SST

METRIC

INOX STAINLESS STEEL

Levelling elements and supports