

Product Brief

Lite DCDC SBC Shield for Arduino

Lite DCDC System Basis Chip Shield with the TLE9471-3ES

The Lite SBC Shield for Arduino uses a TLE9471-3ES, which is part of the TLE94x1 Lite SBC family of Infineon's SBC portfolio.

The SBC enables the shield to drive 9 WS2812B RGB LEDs with its integrated powerful buck converter as well as feature and integrated charge pump to switch external loads up to 2.5 amps. In addition, the shield feature a microchip MCP2515 CAN protocol handler enables CAN communication up to 1 Mb/s.

If desired, the user can also connect an external signal to the high voltage "WK" input to either control the power mode of the SBC or to read the level of the signal.

All functions can be used independently.

A Microcontroller Library offers an intuitive user interface to quickly setup and configure the SBC. Moreover, different code examples are available which can be used as a reference for further projects.

Key benefits

- > Easy to use reference code examples for CAN communication, LED control and configuration of the Lite SBC
- > Lite SBC Microcontroller Library based on Config Wizard available for easy device initialization

Block diagram of the shield

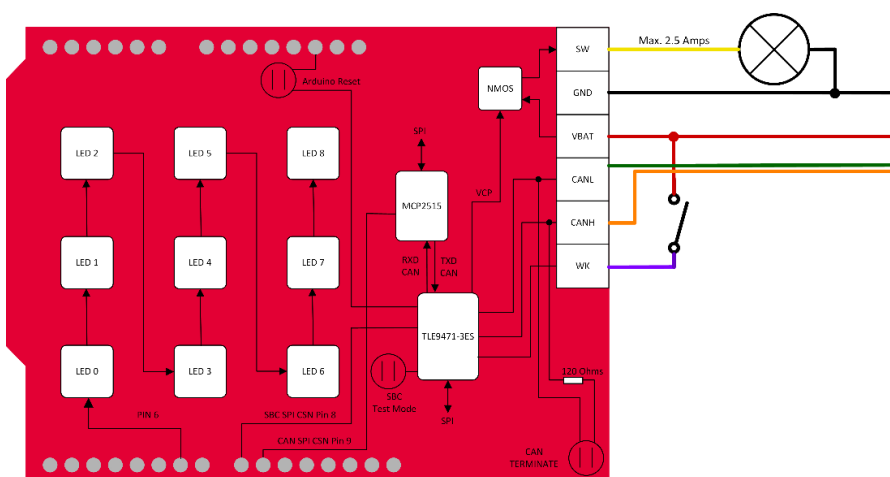

Key features

- > Supply voltage range 9V to 12V
- > 9 WS2812B LEDs powered by the integrated buck converter of TLE9471-3ES
- > Microchip MCP2515 SPI-CAN protocol handler for CAN communication
- > Power MOSFETs driven by the integrated charge pump of the Lite SBC to switch loads up to 2.5 amps. An external freewheeling diode allows switching of inductive loads
- > High voltage level input for wake signalization and/or standard high voltage input
- > Switchable 120 Ohm CAN termination
- > Switchable SBC test mode and reset for Arduino

Key applications of shield

- > Intelligent room lighting
- > Connected LED pixel arrays for e.g. pixel walls
- > RC applications
- > IO node for CAN bus networks
- > Distributed power control of e.g. motors, heating, lighting
- > Pinball machine

Software

A microcontroller library for the TLE9471-3ES is available inside the Infineon Toolbox.

Arduino code examples and user manuals for the shield and for the microcontroller library are available under <https://github.com/Infineon/SBC-for-Arduino/>

About TLE9471-3ES

The TLE9471-3ES is a monolithically integrated circuit in an exposed pad PG-TSDSO-24-1 (150 mil) power package. The device is designed for various CAN automotive applications as main supply for the microcontroller and as interface for a CAN bus network including the CAN Partial Networking feature. To support these applications, the System Basis Chip (SBC) provides the main functions, such as a 5 V lowdropout voltage regulator (Buck SMPS) for e.g. a microcontroller supply, another 5 V low-dropout voltage regulator with off-board protection for e.g. sensor supply, a HS-CAN transceiver supporting CAN FD and CAN Partial Networking (incl. FD tolerant mode) for data transmission, a high-voltage GPIO with embedded protective functions and a 16-bit Serial Peripheral Interface (SPI) to control and monitor the device. Also implemented are a configurable timeout / window watchdog circuit with a reset feature, one Fail Output and an undervoltage reset feature. The device offers low-power modes in order to minimize current consumption on applications that are connected permanently to the battery. A wake-up from the low-power mode is possible via a message on the buses, via the bi-level sensitive monitoring/wake-up input as well as via cyclic wake.

Useful links:

www.infineon.com/lite-sbc

www.infineon.com/shields-for-arduino

github.com/Infineon/SBC-for-Arduino

Order Nr: SBCSHIELDTLE9471TOBO1

Related Products: [TLE9471 family](#), [TLE9471-3ES](#), [Lite DCDC SBC Board](#)

Contain: LTE9471-3ES, 9 WS2812B RGB LEDs, MCP2515

Published by
Infineon Technologies AG
85579 Neuburg, Germany

© 2019 Infineon Technologies AG.
All Rights Reserved.

Please note!

THIS DOCUMENT IS FOR INFORMATION PURPOSES ONLY AND ANY INFORMATION GIVEN HEREIN SHALL IN NO EVENT BE REGARDED AS A WARRANTY, GUARANTEE OR DESCRIPTION OF ANY FUNCTIONALITY, CONDITIONS AND/OR QUALITY OF OUR PRODUCTS OR ANY SUITABILITY FOR A PARTICULAR PURPOSE. WITH REGARD TO THE TECHNICAL SPECIFICATIONS OF OUR PRODUCTS, WE KINDLY ASK YOU TO REFER TO THE RELEVANT PRODUCT DATA SHEETS PROVIDED BY US. OUR CUSTOMERS AND THEIR TECHNICAL DEPARTMENTS ARE REQUIRED TO EVALUATE THE SUITABILITY OF OUR PRODUCTS FOR THE INTENDED APPLICATION.

WE RESERVE THE RIGHT TO CHANGE THIS DOCUMENT AND/OR THE INFORMATION GIVEN HEREIN AT ANY TIME.

Additional information

For further information on technologies, our products, the application of our products, delivery terms and conditions and/or prices please contact your nearest Infineon Technologies office (www.infineon.com).

Warnings

Due to technical requirements, our products may contain dangerous substances. For information on the types in question please contact your nearest Infineon Technologies office.

Except as otherwise explicitly approved by us in a written document signed by authorized representatives of Infineon Technologies, our products may not be used in any life endangering applications, including but not limited to medical, nuclear, military, life critical or any other applications where a failure of the product or any consequences of the use thereof can result in personal injury.