



AH4724 Series



1. Features of AH4724 Series:

- Ferrite based SMD inductor with lower core loss.
- Inductance range: 180.0 nH to 365.0 nH , custom values are welcomed.
- High current output chokes up to 95.0 Amp with approx. 20% roll off.
- Low profile 6.0mm Max. height.
- 12.1 x 10.0 mm Foot Print.
- Ideal for Buck Converter, VRM & High Density Board Design.
- Operating frequency of up to 5.0MHz.
- Operating temperature range of -55° C to + 130° C. RoHS & HF compliant.
- T & R Qty's: 500pcs, 13" Reel.



2. Electrical Characteristics of AH4724 Series:

ITG Part Number	OCL ¹	DCR ³	Isat1 ⁴	Isat2 ⁴	Isat3 ⁴	Irms ⁵
	(nH) ± 10% or 15%	(mΩ) ± 7.0%	(A) @25°C	(A) @45°C	(A) @100°C	(A) @25°C
AH4724-R18KHF	180.00 ,10%	0.48	60.00	58.00	52.00	40.00
AH4724-R21KHF	215.00 ,10%	0.48	54.00	50.00	47.00	40.00
AH4724-R23KHF	230.00 ,10%	0.48	47.00	45.00	42.00	40.00
AH4724-R32KHF	325.00 ,10%	0.48	32.00	31.00	29.00	40.00
AH4724-R36LHF	365.00 ,15%	0.48	30.00	29.00	27.00	40.00

3. Mechanical Dimension of AH4724 Series:

A	B	C	D	E	F	G
Max.	Max.	Max.	Max.	Nom.	Nom.	Nom.
10.00	11.70	6.00	12.10	7.00	3.80	2.30

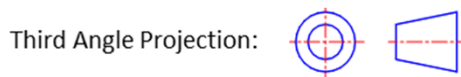
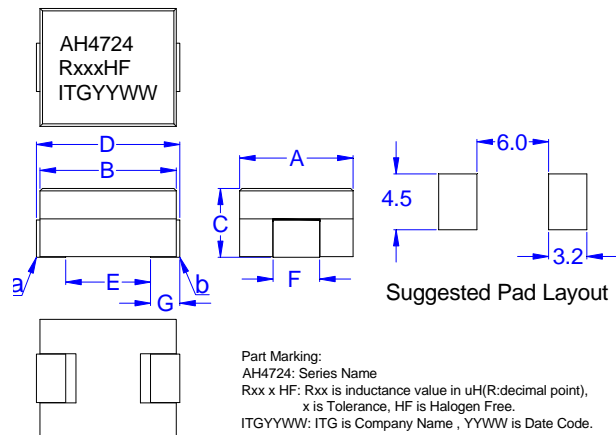

Notes:

1. Open Circuit Inductance (OCL) test condition: 500KHz,0.25Vrms,0A_{dc} at 25°C.
2. L @ Isat and L @ Irms Test condition: 500KHz,0.25Vrms (Ta=25°C).
3. The nominal DCR is measured from point "a" to point "b",as shown above on the mechanical drawing (Ta=25°C).
4. Isat1 , Isat2 & Isat3 : DC current that will cause inductance to drop approximately by 20%.
5. Irms: DC current for an approximate temperature rise of 40°C without core loss. Derating is necessary for AC currents. PCB pad layout,trace thickness and width,air-flow and proximity of other heat generating components will affect the temperature rise.
6. It is recommended the part temperature not exceed 130° C under worst case operating conditions as verified in the end application.

● New York 1 914 347 2474 ● Taipei 886 2 2698 8669 ● Kaohsiung 886 7 350 2275
 ● Japan 81 568 85 2830 ● Shenzhen 86 755 8418 6263 ● Shanghai 86 21 5424 5141 ● Hong Kong 852 9688 9767
 ● sales@ITG-Electronics.com ● www.ITG-Electronics.com Revision E.0 : March 29 , 2018

*Due to continuous product improvement, all specifications are subject to change without prior notice. Kindly contact an ITG field application engineer or a sales representative prior to purchase.



AH4724 Series



4. Inductance Characteristics of AH4724 Series (Inductance vs Current):

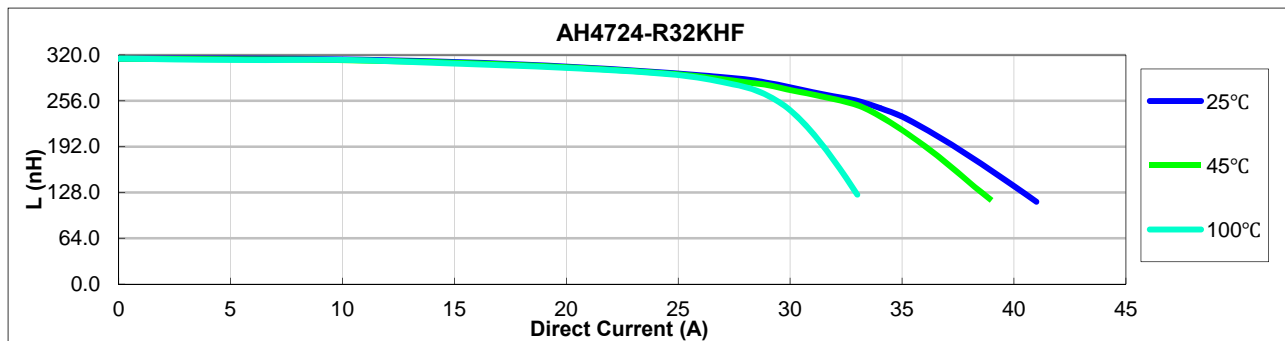
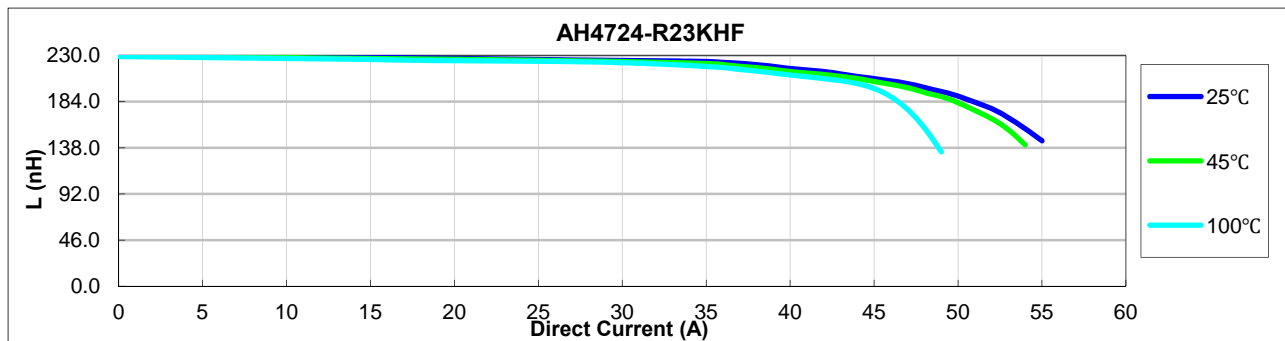
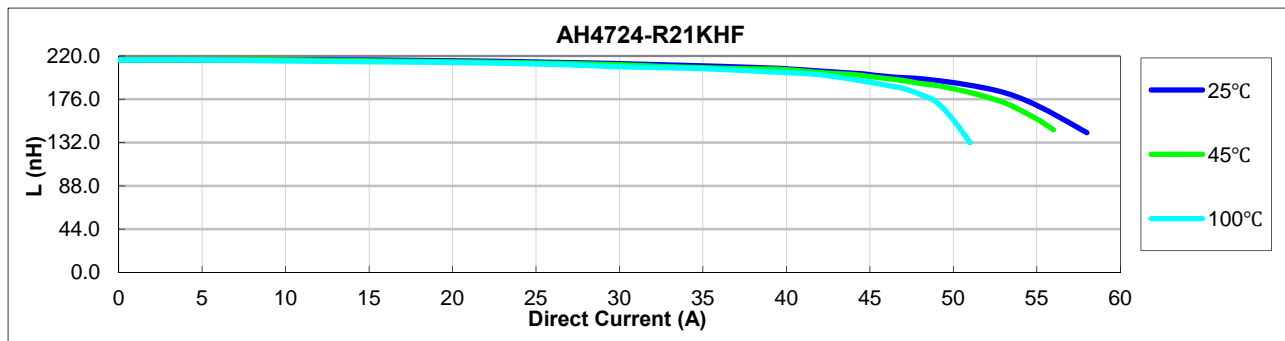
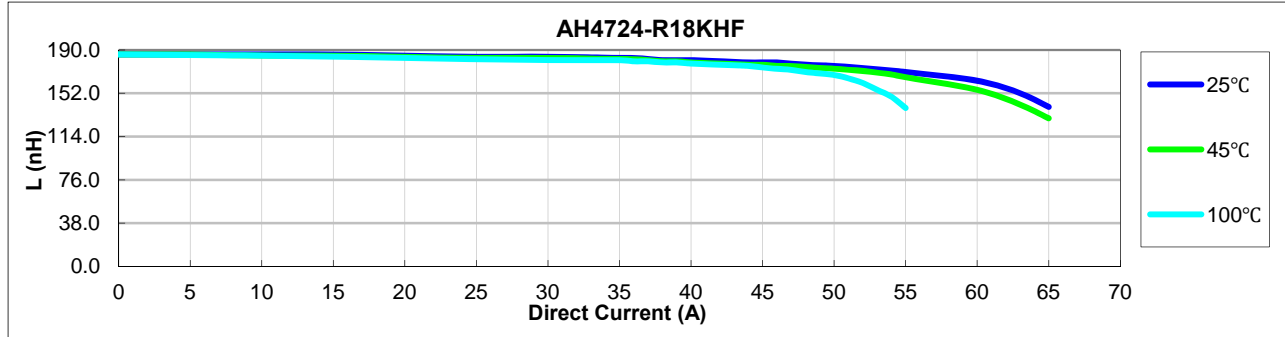

● New York 1 914 347 2474 ● Taipei 886 2 2698 8669 ● Kaohsiung 886 7 350 2275
 ● Japan 81 568 85 2830 ● Shenzhen 86 755 8418 6263 ● Shanghai 86 21 5424 5141 ● Hong Kong 852 9688 9767
 ● sales@ITG-Electronics.com ● www.ITG-Electronics.com Revision E.0 : March 29 , 2018

**Due to continuous product improvement, all specifications are subject to change without prior notice. Kindly contact an ITG field application engineer or a sales representative prior to purchase.*



AH4724 Series



4. Inductance Characteristics of AH4724 Series (Inductance vs Current):

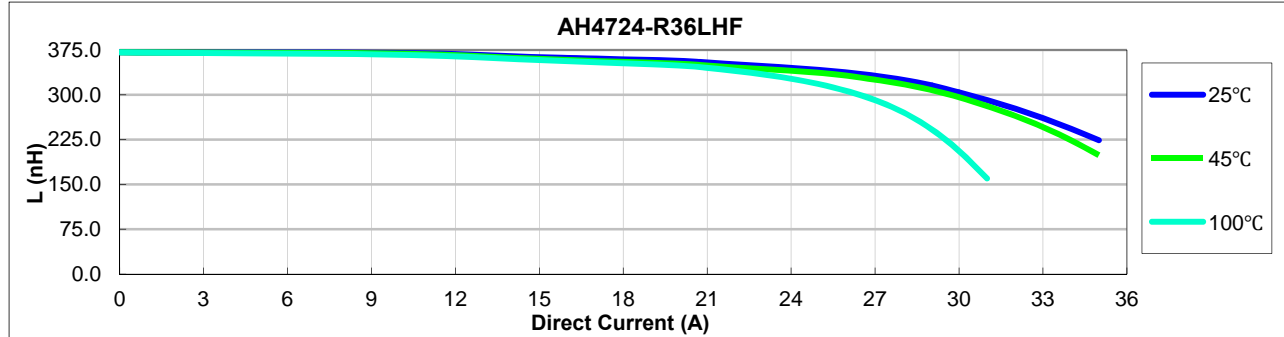

● New York 1 914 347 2474 ● Taipei 886 2 2698 8669 ● Kaohsiung 886 7 350 2275
● Japan 81 568 85 2830 ● Shenzhen 86 755 8418 6263 ● Shanghai 86 21 5424 5141 ● Hong Kong 852 9688 9767
● sales@ITG-Electronics.com ● www.ITG-Electronics.com Revision E.0 : March 29 , 2018

**Due to continuous product improvement, all specifications are subject to change without prior notice. Kindly contact an ITG field application engineer or a sales representative prior to purchase.*



AH4724 Series



6. PACKAGE SPECIFICATION.(UNIT:mm):

(1).ENCAPSULATION MODE:

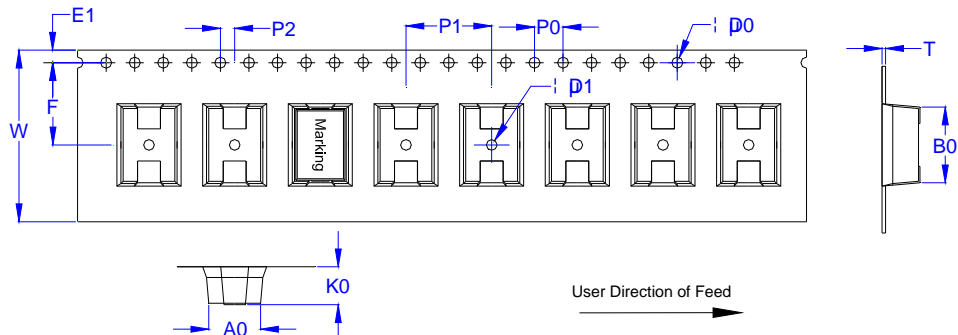

(2).DIMENSION(mm):

W	A0	B0	K0	P1	P0	P2	D0	D1	F	E1	T
24.0+0.3/-0.1	10.2±0.1	12.3±0.10	6.20±0.10	16.0±0.10	4.00±0.10	2.00±0.10	1.50+0.10/-0	1.50+0.10/-0	11.5±0.10	1.75±0.10	0.40±0.05

(3).REEL SIZE:

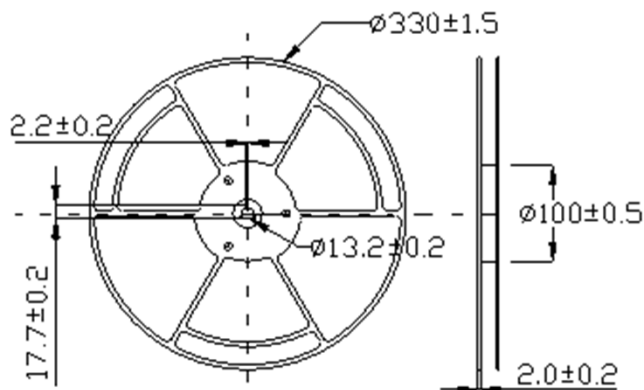

(4).PACKAGE MODE:

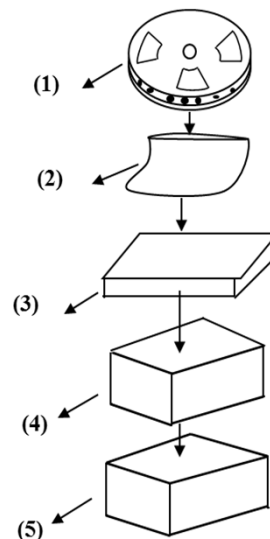

(5).PACKAGING LIST:

No.	Packing Part	Dimension (mm)	Material	Quantity
1	Reel	330	Plastic	500Pcs/Reel
2	Bag	450x360x0.075	Plastic	1Reel/Bag
3	Small Box	340X335X45	Paper	1Bag/Small Box
4	Middle Box	356X350X226	Paper	4Small Boxes/Middle Box
5	Outer Box	378X362X252	Paper	1Middle Box/Outer Box

(6).WEIGHT: N.W: 2.95 g/pcs (APPROX), TOTAL 5.95 Kg(APPROX),G.W:TOTAL 8.90Kg (APPROX).

(7).Storage conditions: -40°C~85°C ,75%RH (Max.).

● New York 1 914 347 2474 ● Taipei 886 2 2698 8669 ● Kaohsiung 886 7 350 2275
 ● Japan 81 568 85 2830 ● Shenzhen 86 755 8418 6263 ● Shanghai 86 21 5424 5141 ● Hong Kong 852 9688 9767
 ● sales@ITG-Electronics.com ● www.ITG-Electronics.com Revision E.0 : March 29 , 2018

*Due to continuous product improvement, all specifications are subject to change without prior notice. Kindly contact an ITG field application engineer or a sales representative prior to purchase.



AH4724 Series



7.RELIABILITY TEST:

TEST ITEMS	SPECIFICATIONS	TEST METHOD AND REMARKS
Solder ability	The electrodes shall be at least 90% covered with new solder coating	According to IEC68-2-20. 1. Soldering temperature:245±5°C 2. Solder:99.3Sn/0.7Cu 3. Flux:Rosin 4. Immersion time:5±1Sec
Soldering heat resistance	1. Appearance :no damage 2. Inductance change:within± 10%of initial value	1. Preheat temperature150°C. 2. Preheat time:1min 3. Solder temperature260±5°C 4. Dipping time:10±1Sec 5. Measured at room temperature after placing for 24hours
Vibration(OUT LAB)	1. Appearance:no damage 2. All Electrical and mechanical parameters within tolerance	According to MIL-STD-202 Method 204. 1.Frequency:10 to 55Hz. 2.Amplitude:1.52mm 3.Direction and timeX Y and Z Direction for 2 hours each
Humidity resistance test	1. Appearance: no damage 2. All Electrical and mechanical parameters within tolerance	According to IEC68-2-1MethodCa: 1. Temp:40±2°C 2. Humidity:90%-95%RH 3. Test time:500±2H 4. The component should be stabilized at normal condition for24 Hours before test
High temperature resistance test	1. Appearance: no damage 2. All Electrical and mechanical parameters within tolerance	According to IEC68-2-2. 1. 1. Temperature:85±3°C 2. Test time:500+24H 3. The component should be stabilized at normal condition for 24hours before test
Low Temperature resistance test	1. Appearance: no damage 2. All Electrical and mechanical parameters within tolerance	According to IEC68-2-1 Method A(Ad). 1. Temperature:-40±3°C 2. Test time:500+24H 3. The component should be stabilized at normal condition for 24hours before test
Temperature cycles test	1. Appearance: no damage 2. All Electrical and mechanical parameters within tolerance	According to IEC68-2-14 Method N(Nb). 1. High-temp:85±3duration:30min 2. room -temp:25±2°CDuration3H 3. Low-temp:-40±3Duration30min 4. room-temp: 25±2°CDuration3H 5. Number of cycle:10cycles 6. The component should be stabilized at normal condition for 24hours before test

● New York 1 914 347 2474 ● Taipei 886 2 2698 8669 ● Kaohsiung 886 7 350 2275
 ● Japan 81 568 85 2830 ● Shenzhen 86 755 8418 6263 ● Shanghai 86 21 5424 5141 ● Hong Kong 852 9688 9767
 ● sales@ITG-Electronics.com ● www.ITG-Electronics.com Revision E.0 : March 29 , 2018

**Due to continuous product improvement, all specifications are subject to change without prior notice. Kindly contact an ITG field application engineer or a sales representative prior to purchase.*



AH4724 Series



Soldering Reflow Chart

Stage	Precaution	Recommended temperature profile
Reflow soldering	<p>Temperature profile can be referenced after confirming of adhesion , temperature of resistance to soldering heat , component size , soldering etc. sufficient .</p> <p>Note: please refer to the latest IPC/JEDEC J-STD-020: "Moisture/Reflow Sensitivity Classification for Nonhermetic Solid State Surface Mount Devices"</p>	<p>The graph shows a reflow temperature profile. The y-axis is Temperature in °C, with markers at 25, 125, 220, 250, and 260. The x-axis represents time in seconds. The profile starts at 25°C, ramps up to 125°C (150s to 210s), then to 220°C (240s to 480s), peaks at 260°C (10s MAX), and finally cools down (60s to 90s). A shaded cyan area highlights the ramping phase from 125°C to 220°C. The cooling phase is labeled 'Natural cooling'.</p>

● New York 1 914 347 2474 ● Taipei 886 2 2698 8669 ● Kaohsiung 886 7 350 2275
 ● Japan 81 568 85 2830 ● Shenzhen 86 755 8418 6263 ● Shanghai 86 21 5424 5141 ● Hong Kong 852 9688 9767
 ● sales@ITG-Electronics.com ● www.ITG-Electronics.com Revision E.0 : March 29 , 2018

**Due to continuous product improvement, all specifications are subject to change without prior notice. Kindly contact an ITG field application engineer or a sales representative prior to purchase.*