

PART NUMBER	REVISION	DESCRIPTION	FEED TYPE
2150253-2	D	FINE CRIMP HEIGHT ADJUST	PNEUMATIC
7-2150253-2	D	PNEUMATIC AND CRIMP TOOLING KIT	PNEUMATIC
7-2150253-7	A	CRIMP TOOLING KIT	-

ATLANTIC VERSION TERMINATOR INTERFACE ADAPTER

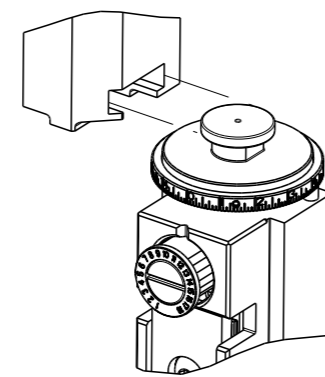

APPLICATOR DATA		
CRIMP	SIZE	TYPE
WIRE	6.02 mm [.237]	D
INSUL	-	-
APPL INSTRUCTIONS 408-35043		

TERMINAL DATA: TE TERMINAL		TE CRIMP SPECIFICATION	
TERMINAL NAME: RECPT, ULTRA-FAST FLAG, .250 SERIES			
WIRE STRIP LENGTH		INSULATION DIAMETER RANGE	
7.51-8.33 mm [.296-.328 IN]		∅ 4.70mm MAX [.185 MAX]	
TERMINAL APPLICATION SPECIFICATION	114-2123	-	-
TERMINALS APPLIED			
TE TERMINAL	TE TERMINAL	TE TERMINAL	TE TERMINAL
3-520132-2	9-520132-2	3-521127-2	

WIRE SIZE	CRIMP HEIGHT mm [INCH]	CRIMP HEIGHT REFERENCE SETTING	∅ SOLDER
14	1.90+/-0.05 [.075+/-0.002]	6.7	.19 in [4.83mm]
16	1.78+/-0.05 [.070+/-0.002]	8.0	.19 in [4.83mm]



- RECOMMENDED SPARE PARTS
- REFER TO SUPPLIED INSTRUCTION SHEET FOR CLEANING, LUBRICATION AND STORAGE OF APPLICATOR.
- CRIMP HEIGHT REFERENCE SETTING WAS THE SETTING USED WHEN THE APPLICATOR WAS QUALIFIED AT THE FACTORY. ADJUSTMENT MAY BE NECESSARY WHEN RUNNING APPLICATOR IN THE FIELD.
- TERMINAL PITCH NOT COMPATIBLE WITH MECHANICAL FEED.
- TO CHECK CRIMP HEIGHT, CRIMP SOLDER (∅.19 IN [4.83mm] 60/40 SOLID CORE) AND MEASURE AT CENTER OF SLUG.

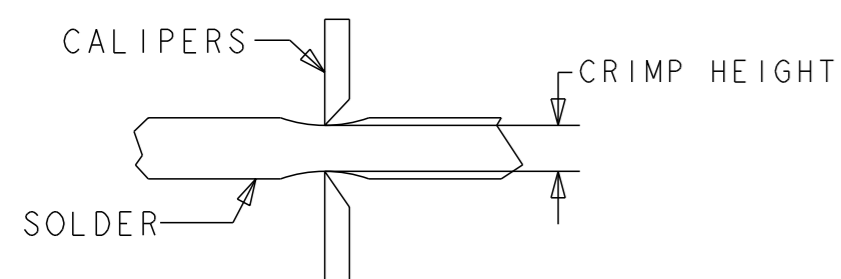

7. UNLESS SPECIFIED OTHERWISE TORQUE VALUES SHALL BE USED PER DOCUMENT, 101-35000.

**\*WARNING**  
ON INSTALLATION, SET WIRE DISC TO CRIMP HEIGHT REFERENCE SETTING FOR LARGEST WIRE SIZE. CRIMP HEIGHT REFERENCE SETTINGS GREATER THAN THE VALUE SHOWN MAY CAUSE DAMAGE TO THE CRIMP TOOLING. REFER TO THE INSTRUCTION SHEET FOR PROPER SETUP AND ADJUSTMENTS.

LOC	DIST	REVISIONS					
A	66	P	LY#	DESCRIPTION	DATE	OWN	APVD
		A1		ECR-13-012598	08AUG2013	XZ	TE
		B		ECR-14-003864	14MAR2014	YY	UG
		C		ECR-18-012215	01AUG2018	JAH	CT
		D		ECR-19-008826	05JUN2019	LG	TE

-	1	1	2119641-1	FEED CAM, AIR FEED	248		
-	1	1	2844940-3	AIR FEED MODULE	238		
-	2	2	2168400-4	SHCS, LOW HEAD, RoHS, M4 X 8	208		
-	1	1	467281-1	RETAINER, SHEAR, FLOATING	207		
-	1	1	2161936-1	HOLDER, SHEAR, FLOATING	206		
-	1	1	467500-1	SHEAR, FLOATING	205		
-	1	1	1-18028-0	WASHER, FLAT, REG M8	192		
-	REF	REF	994970-2	COUNTER, MAGNETIC	164		
-	1	1	2161937-1	STABILIZER	154		
-	1	1	455888-5	SPACER, CRIMPER	82		
-	1	1	1803607-4	DOCUMENTATION PACKAGE	71		
-	1	1	3-18032-3	SCR, SET, FLT PNT, M3 X 20.0	70		
-	1	1	2-18032-2	SCR, SET, FLT PNT, M3 X 10.0	69		
-	1	1	2119740-1	TAG, IDENTIFICATION	67		
-	2	2	2168078-1	SCREW, DRIVE, RH, RoHS, 2 x .188	66		
-	1	1	2079383-4	SCR, BHSC, RoHS (M4 X 8)	60		
-	1	1	5-18022-5	SCR, HEX HD CAP, M4 X 6.0	59		
-	4	4	2168400-1	SHCS, LOW HEAD, RoHS, M4 X 12	57		
-	2	2	2168083-2	SCR, SKT HD CAP, RoHS, M4 X 8.0	56		
-	2	2	5018030-1	NUT, HEX, REG, RoHS, M3	54		
-	2	2	986965-8	NUT, LOCK, HEX, TORQUE (M4)	53		
-	1	1	2352966-1	FEED FINGER	51		
-	1	1	18023-9	SCR, SKT HD CAP M4 X 6.0	49		
-	1	1	1-2119655-5	APPLICATOR BASIC ASSEMBLY, EF	46		
-	1	1	1803517-1	RAM ASSEMBLY, EF ATLANTIC	44		
-	1	1	1803602-1	SCR, BHSC, RoHS (M8 X 25)	41		
-	2	2	5-22278-1	SPRING, COMPRESSION	36		
-	8	8	1-18028-2	WASHER, FLAT, REG M4	33		
-	2	2	2079383-4	SCR, BHSC, RoHS (M4 X 8)	31		
-	2	2	2168083-2	SCR, SKT HD CAP, RoHS, M4 X 8.0	29		
-	1	1	240639-1	STRIPPER (MACHINING)	27		
-	2	2	1-2168083-6	SCR, SKT HD CAP, RoHS, M4 X 35	25		
-	1	1	2161941-1	PLATE, GUIDE, STRIP	24		
-	2	2	2-22281-3	SPRING, COMPRESSION	22		
-	1	1	2161948-1	DRAG	20		
-	1	1	683736-1	GUIDE, STRIP, REAR	19		
-	1	1	683737-1	FRONT STRIP GUIDE	18		
-	4	4	1-2079383-1	SCR, BHSC, RoHS (M6 X 12)	17		
-	1	1	4-22280-7	SPRING, COMPRESSION	13		
	1	2	1	2161935-2	ANVIL, RIGHT HAND	8	
-	1	1	1	2161957-1	DEPRESSOR, SHEAR	5	
-	1	1	1	238011-2	BLOCK, CRIMPER SPACER	4	
-	1	1	1	2161331-1	SPACER, WIRE FUNNEL DEPRESSOR	2	
	1	2	1	467342-2	CRIMPER, RIGHT HAND	1	
				-77-72-2	PART NO		
					DESCRIPTION		ITEM NO

ATLANTIC VERSION  
Shown on sheets 1 of 4 & 2 of 4  
(Pacific version shown on sheets 3 of 4 & 4 of 4)

DIMENSIONS:		TOLERANCES UNLESS OTHERWISE SPECIFIED:		OWN: HOFFNER 10MAY2012		TE Connectivity	
mm		0 PLC ±		CHK: T. ELBIN 11MAY2012		Harrisburg, PA 17105-3608	
		1 PLC ±		APVD: T. ELBIN 11MAY2012		NAME: Ocean End Feed Applicator	
		3 PLC ±		PRODUCT SPEC		SIZE: A1	
		4 PLC ±		APPLICATION SPEC		CAGE CODE: 00779	
		ANGLES FINISH ±		WEIGHT: -		DRAWING NO: 2150253	
MATERIAL: -		FINISH: -		RESTRICTED TO: -		SCALE: 1:1	
				Customer Accessible Production Drawing		SHEET 1 OF 4	

LOC	DIST	REVISIONS			
A	66	REV	DATE	OWN	APVD
		-	SEE SHEET 1	-	-

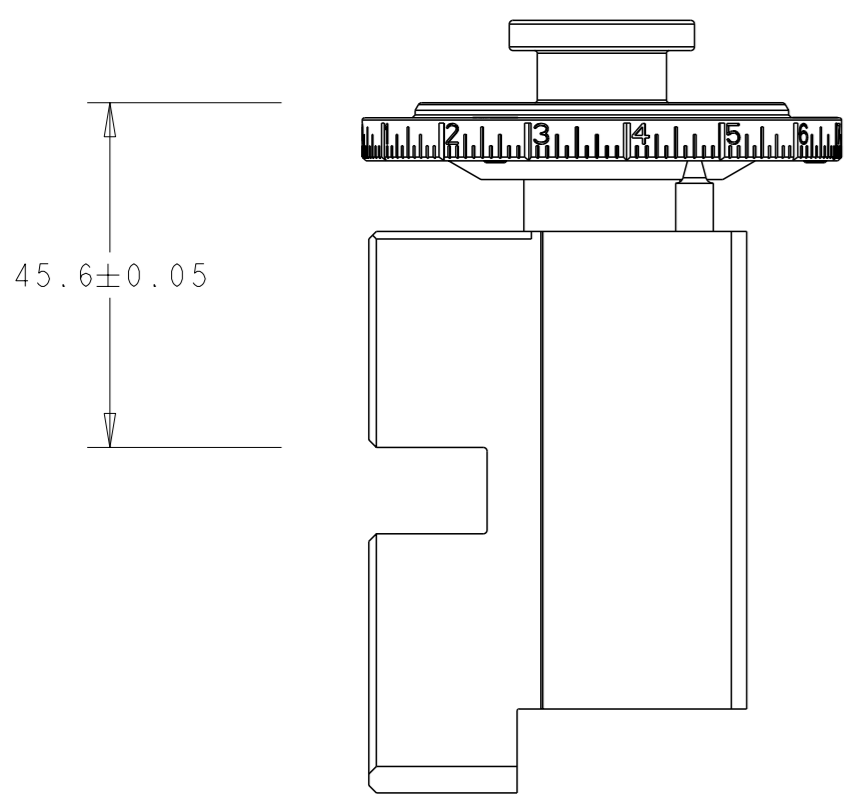

RAM SET-UP

FEED TYPE

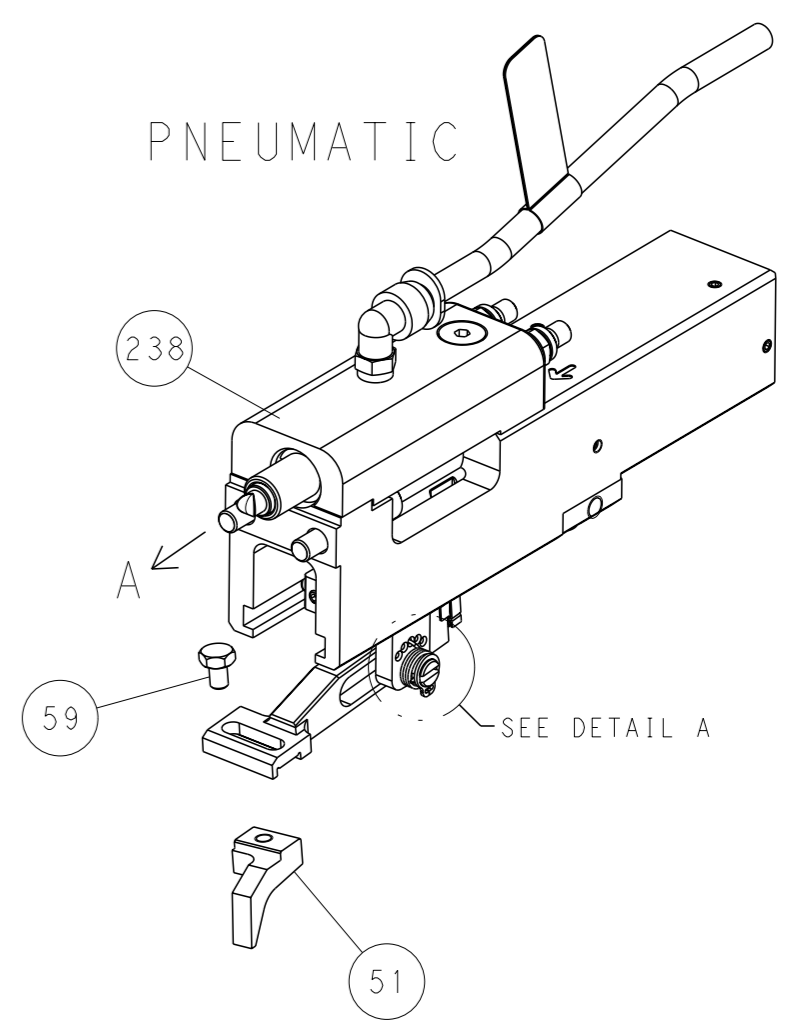

FEED SPRING SETTING POSITION

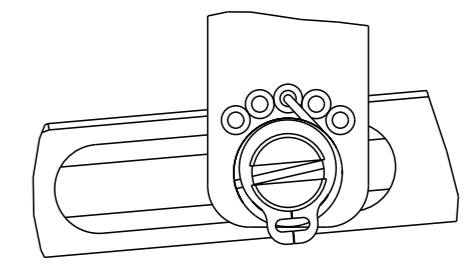

DETAIL A

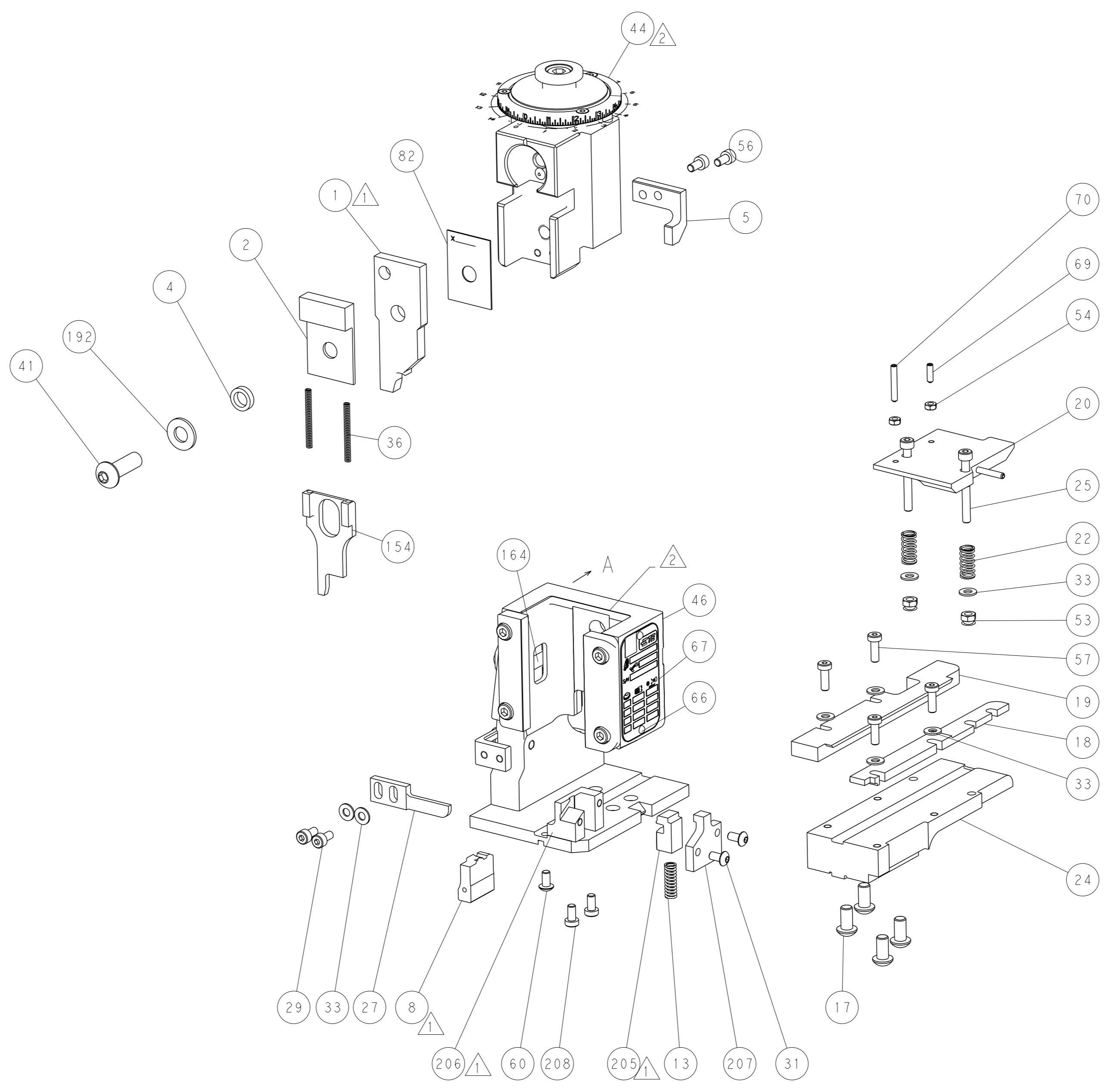

CAM POSITION

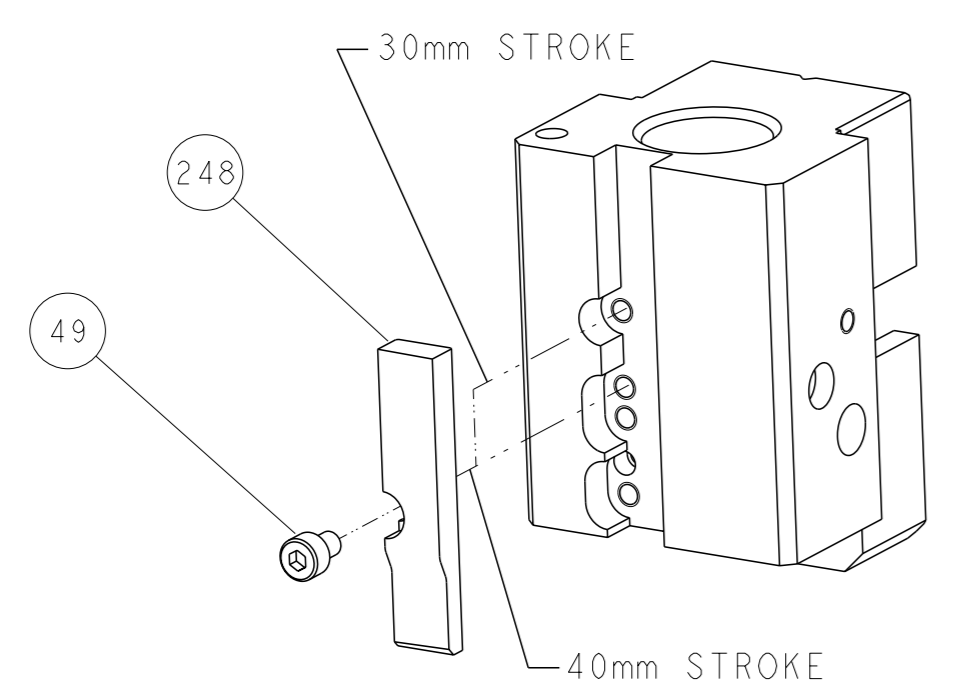

AIR FEED

ATLANTIC VERSION  
 Shown on sheets 1 of 4 & 2 of 4  
 (Pacific version shown on sheets 3 of 4 & 4 of 4)

<small>THIS DRAWING IS A CONTROLLED DOCUMENT FROM TYCO ELECTRONICS CORPORATION. IT IS SUBJECT TO CHANGE AND ITS CONTENTS AND EXISTING DESIGNATION SHOULD BE CONTACTED FOR THE LATEST REVISION.</small>		OWN: HOFFNER 10MAY2012 CHK: T. ELBIN 11MAY2012 APVD: T. ELBIN 11MAY2012	TE Connectivity Harrisburg, PA 17105-3608
DIMENSIONS: mm TOLERANCES UNLESS OTHERWISE SPECIFIED: 0 PLC ± 1 PLC ± 2 PLC ± 3 PLC ± 4 PLC ± ANGLES FINISH ±		NAME: Ocean End Feed Applicator SIZE: A1 CAGE CODE: 00779 DRAWING NO: C=2150253	RESTRICTED TO: - SCALE: 1:1 SHEET: 2 of 4 REV: D
MATERIAL: - FINISH: - WEIGHT: -		Customer Accessible Production Drawing	

PART NUMBER	REVISION	DESCRIPTION	FEED TYPE
2-2150253-2	D	FINE CRIMP HEIGHT ADJUST	PNEUMATIC
7-2150253-7	A	CRIMP TOOLING KIT	-

PACIFIC VERSION TERMINATOR  
 INTERFACE ADAPTER

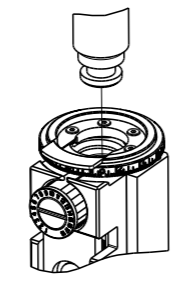

APPLICATOR DATA		
CRIMP	SIZE	TYPE
WIRE	6.02 mm [.237]	D
INSUL	-	-
APPL INSTRUCTIONS 408-35043		

TERMINAL DATA: TE TERMINAL		TE CRIMP SPECIFICATION	
TERMINAL NAME: RECPT, ULTRA-FAST FLAG, .250 SERIES			
WIRE STRIP LENGTH 7.51-8.33 mm [.296-.328 IN]		INSULATION DIAMETER RANGE ∅ 4.70mm MAX [.185 MAX]	
TERMINAL APPLICATION SPECIFICATION 114-2123		-	
TERMINALS APPLIED 4			
TE TERMINAL	TE TERMINAL	TE TERMINAL	TE TERMINAL
3-520132-2	9-520132-2	3-521127-2	

WIRE SIZE	CRIMP HEIGHT mm [INCH]	CRIMP HEIGHT REFERENCE SETTING	∅ SOLDER
14	1.90 +/- 0.05 [0.075 +/- .002]	6.7	.19 in [4.83mm]
16	1.78 +/- 0.05 [0.070 +/- .002]	8.0	.19 in [4.83mm]

**RECOMMENDED SPARE PARTS**

REFER TO SUPPLIED INSTRUCTION SHEET FOR CLEANING, LUBRICATION AND STORAGE OF APPLICATOR.

CRIMP HEIGHT REFERENCE SETTING WAS THE SETTING USED WHEN THE APPLICATOR WAS QUALIFIED AT THE FACTORY. ADJUSTMENT MAY BE NECESSARY WHEN RUNNING APPLICATOR IN THE FIELD.

TERMINAL PITCH NOT COMPATIBLE WITH MECHANICAL FEED.

TO CHECK CRIMP HEIGHT, CRIMP SOLDER (∅.19 IN [4.83mm] 60/40 SOLID CORE) AND MEASURE AT CENTER OF SLUG.

**\*WARNING**  
 ON INSTALLATION, SET WIRE DISC TO CRIMP HEIGHT REFERENCE SETTING FOR LARGEST WIRE SIZE. CRIMP HEIGHT REFERENCE SETTINGS GREATER THAN THE VALUE SHOWN MAY CAUSE DAMAGE TO THE CRIMP TOOLING, REFER TO THE INSTRUCTION SHEET FOR PROPER SETUP AND ADJUSTMENTS.

7. UNLESS SPECIFIED OTHERWISE TORQUE VALUES SHALL BE USED PER DOCUMENT, 101-35000.

LOC	DIST	REVISIONS			
P	LYR	DESCRIPTION	DATE	OWN	APVD
A	66	SEE SHEET 1	-	-	-

-	1	2844940-3	AIR FEED MODULE	238
-	2	2168400-5	SHCS, LOW HEAD, RoHS, M4 X 20	209
-	1	467281-1	RETAINER, SHEAR, FLOATING	207
-	1	2161936-1	HOLDER, SHEAR, FLOATING	206
-	1	467500-1	SHEAR, FLOATING	205
-	1	1-18028-0	WASHER, FLAT, REG M8	192
-	4	2079383-9	SCR, BHSC, RoHS (M6 X 20)	186
-	REF	994970-2	COUNTER, MAGNETIC	164
-	1	2161937-1	STABILIZER	154
-	1	2119641-2	FEED CAM, AIR FEED	152
-	1	2079383-8	SCR, BHSC, RoHS (M4 X 16)	144
-	1	1-2119655-6	APPLICATOR BASIC ASSEMBLY, EF	141
-	1	1803518-1	RAM ASSEMBLY, EF PACIFIC	140
-	1	455888-5	SPACER, CRIMPER	82
-	1	1803607-4	DOCUMENTATION PACKAGE	71
-	1	3-18032-3	SCR, SET, FLT PNT, M3 X 20.0	70
-	1	2-18032-2	SCR, SET, FLT PNT, M3 X 10.0	69
-	1	2119740-1	TAG, IDENTIFICATION	67
-	2	2168078-1	SCREW, DRIVE, RH, RoHS, 2 x .188	66
-	1	5-18022-5	SCR, HEX HD CAP, M4 X 6.0	59
-	4	2168400-1	SHCS, LOW HEAD, RoHS, M4 X 12	57
-	2	2168083-2	SCR, SKT HD CAP, RoHS, M4 X 8.0	56
-	2	5018030-1	NUT, HEX, REG, RoHS, M3	54
-	2	986965-8	NUT, LOCK, HEX, TORQUE (M4)	53
-	1	2352966-1	FEED FINGER	51
-	1	18023-9	SCR, SKT HD CAP M4 X 6.0	49
-	1	1803602-1	SCR, BHSC, RoHS (M8 X 25)	41
-	2	5-22278-1	SPRING, COMPRESSION	36
-	8	1-18028-2	WASHER, FLAT, REG M4	33
-	2	2079383-4	SCR, BHSC, RoHS (M4 X 8)	31
-	2	2168083-2	SCR, SKT HD CAP, RoHS, M4 X 8.0	29
-	1	240639-1	STRIPPER (MACHINING)	27
-	2	1-2168083-6	SCR, SKT HD CAP, RoHS, M4 X 35	25
-	1	2161941-1	PLATE, GUIDE, STRIP	24
-	2	2-22281-3	SPRING, COMPRESSION	22
-	1	2161948-1	DRAG	20
-	1	683736-1	GUIDE, STRIP, REAR	19
-	1	683737-1	FRONT STRIP GUIDE	18
-	1	4-22280-7	SPRING, COMPRESSION	13
1	1	2161935-2	ANVIL, RIGHT HAND	8
-	1	2161957-1	DEPRESSOR, SHEAR	5
-	1	238011-2	BLOCK, CRIMPER SPACER	4
-	1	2161331-1	SPACER, WIRE FUNNEL DEPRESSOR	2
1	1	467342-2	CRIMPER, RIGHT HAND	1

**PACIFIC VERSION**  
 Shown on sheets 3 of 4 & 4 of 4  
 (Atlantic version shown on sheets 1 of 4 & 2 of 4)

DIMENSIONS:		TOLERANCES UNLESS OTHERWISE SPECIFIED:		DRAWING NO.	
mm	0 PLC ±	1 PLC ±	2 PLC ±	3 PLC ±	4 PLC ±
	ANGLES	FINISH			
MATERIAL		FINISH		WEIGHT	
				A1 00779	
				SCALE 1:1	
				SHEET 3 OF 4	
				REV D	

Customer Accessible Production Drawing

LOC	DIST	REVISIONS			
		REV	DATE	BY	APPV
A	66	1			

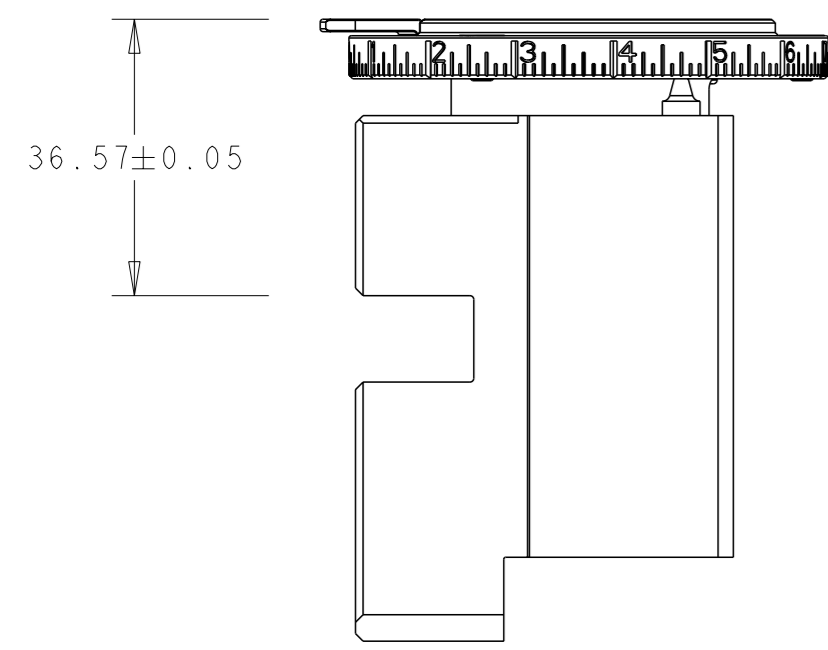

RAM SET-UP

FEED TYPE

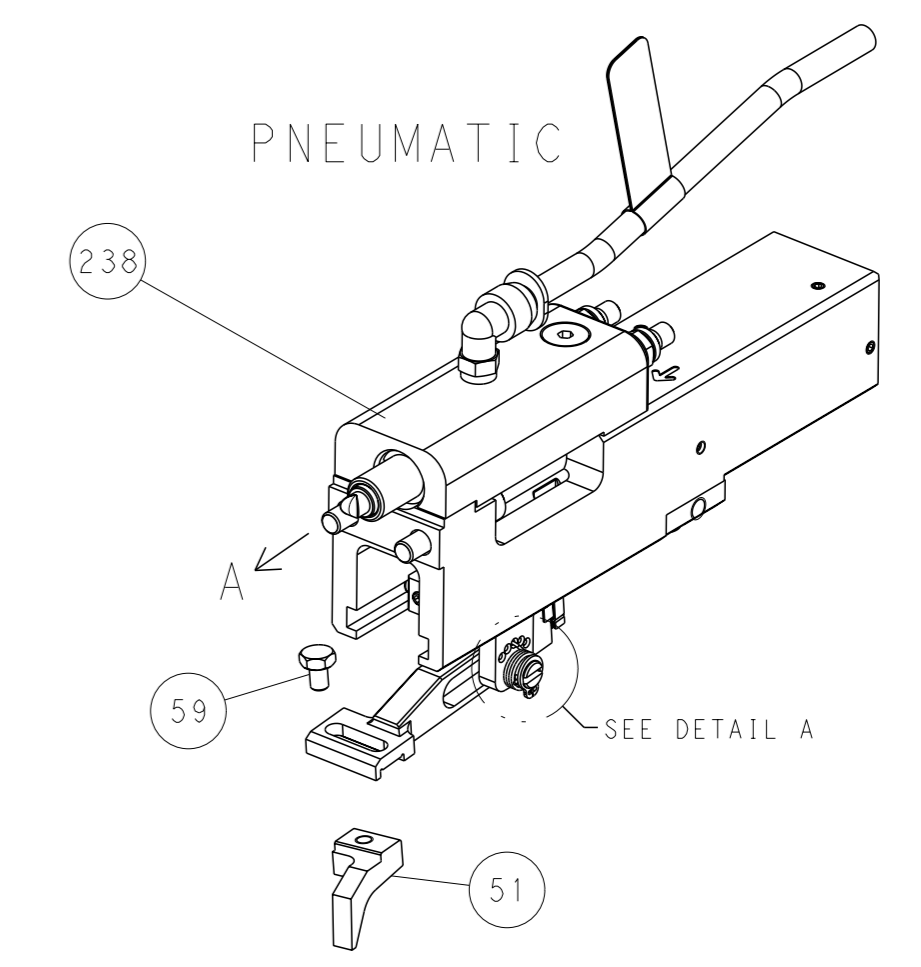

FEED SPRING SETTING POSITION

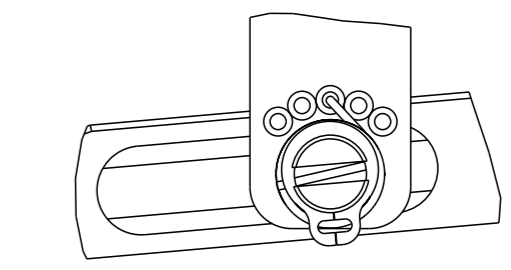

DETAIL A

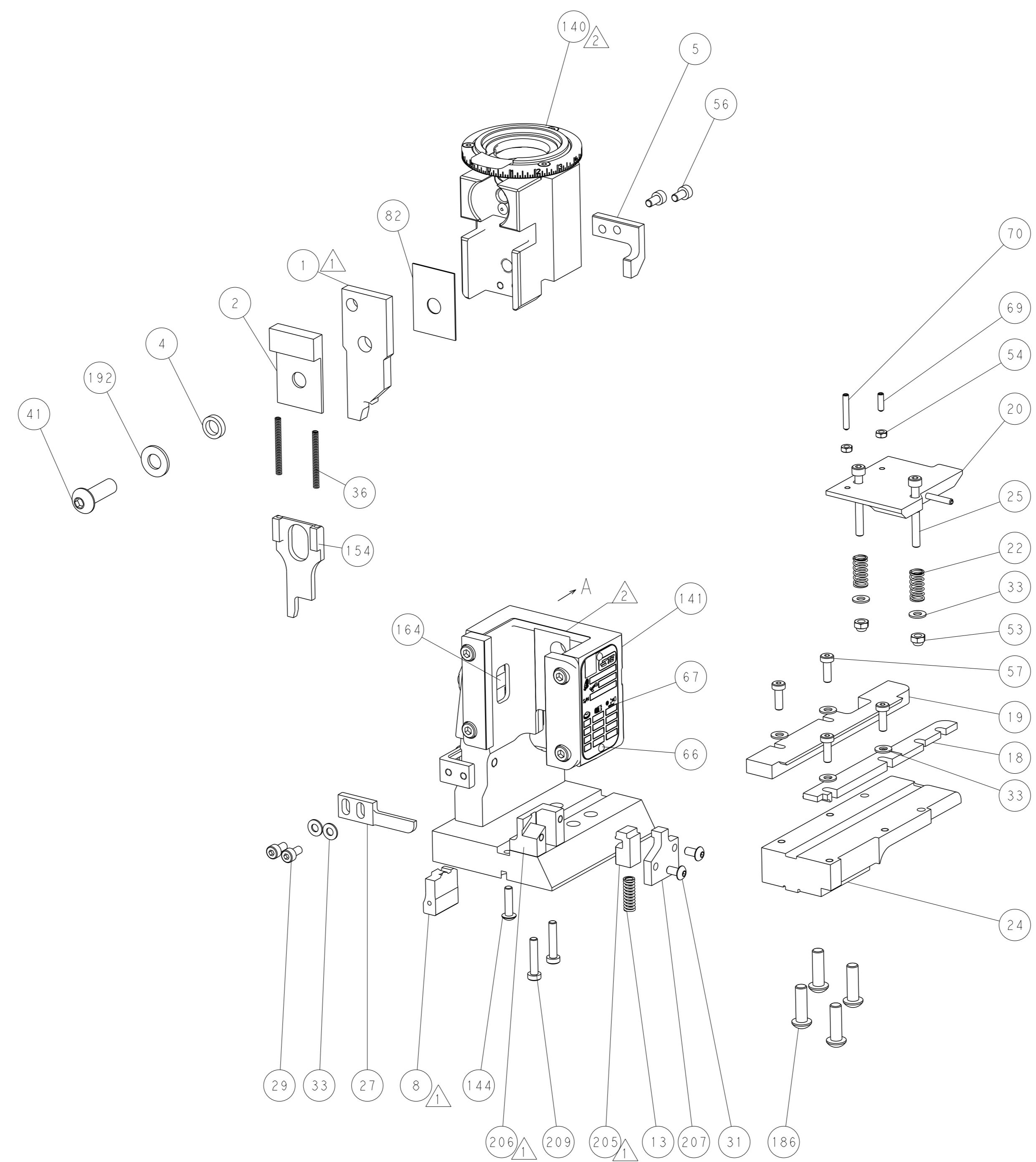

CAM POSITION

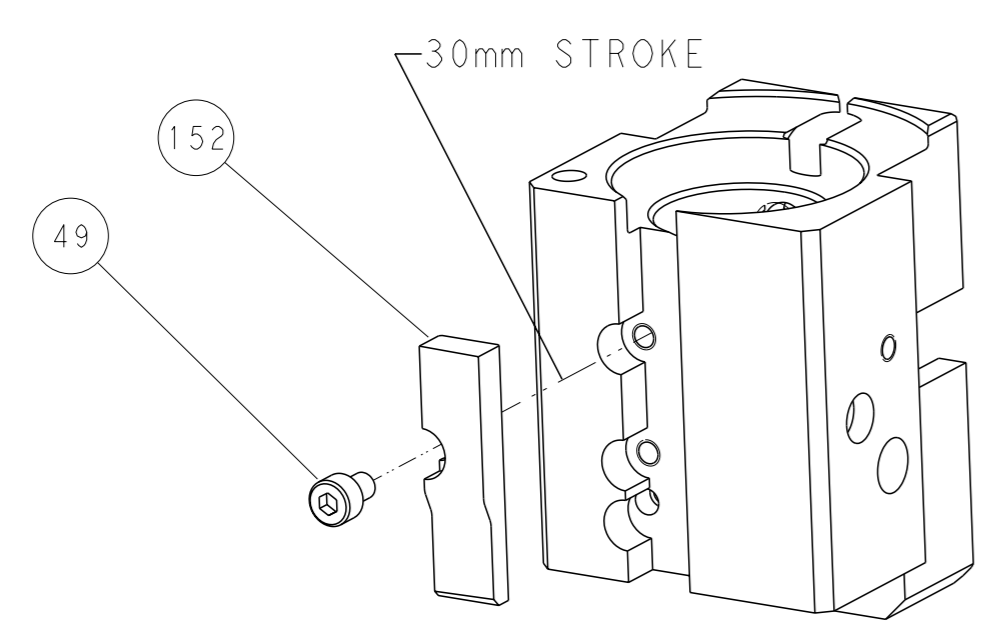

AIR FEED

PACIFIC VERSION  
 Shown on sheets 3 of 4 & 4 of 4  
 (Atlantic version shown on sheets 1 of 4 & 2 of 4)

<small>THIS DRAWING IS A CONTROLLED DOCUMENT FOR TYCO ELECTRONICS CORPORATION. IT IS SUBJECT TO CHANGE AND THE CONTROLLING ENGINEERING ORGANIZATION SHOULD BE CONTACTED FOR THE LATEST REVISION.</small>		DWN: HOFFNER 10MAY2012 CHK: T. ELBIN 11MAY2012 APVD: T. ELBIN 11MAY2012	NAME: STE TE Connectivity Harrisburg, PA 17105-3608
DIMENSIONS: mm TOLERANCES UNLESS OTHERWISE SPECIFIED: 0 PLC ± 1 PLC ± 2 PLC ± 3 PLC ± 4 PLC ± ANGLES FINISH *	APPLICATION SPEC PRODUCT SPEC	SIZE: A1 CAGE CODE: 00779 DRAWING NO: C=2150253	RESTRICTED TO: - SCALE: 1:1 SHEET: 4 of 4 REV: D
MATERIAL: - FINISH: -		WEIGHT: - Customer Accessible Production Drawing	SCALE: 1:1 SHEET: 4 of 4 REV: D