

LOC		DIST		REVISIONS			
P	LTN	DESCRIPTION	DATE	DMN	APVD		
A		RELEASED	08NOV11	EW	KO		
A1		REVISED ECO-15-009724	23JUN15	RZ	WY		

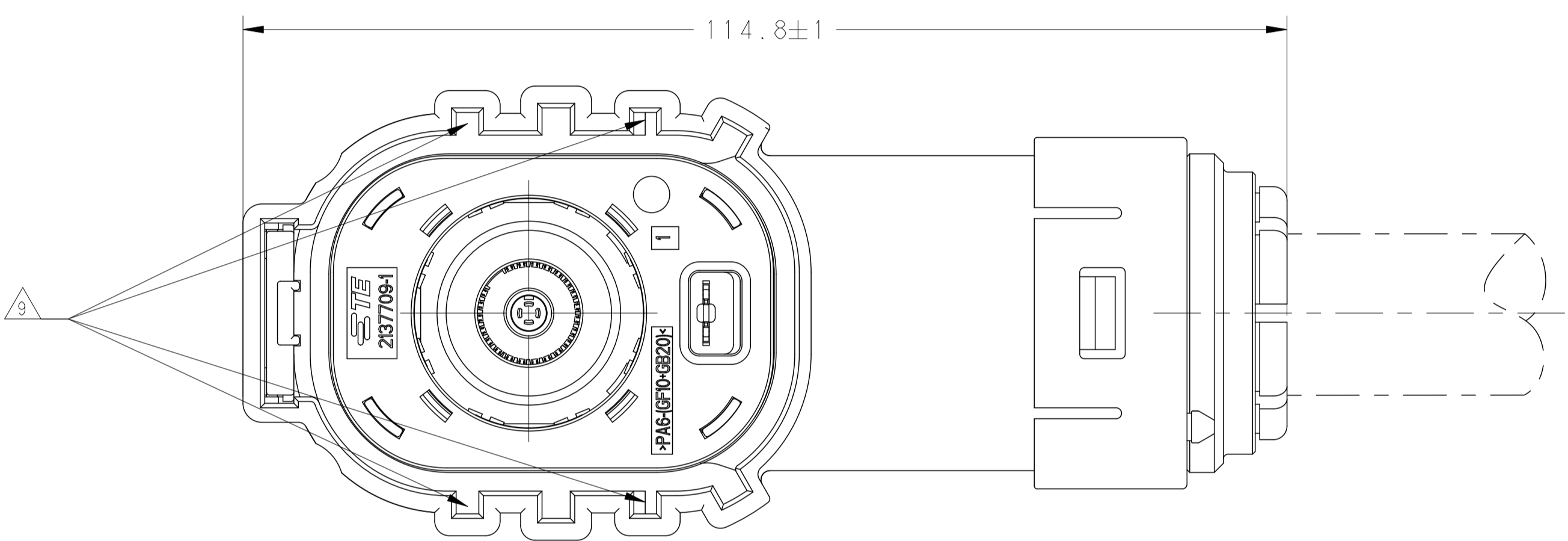

NOTES

- COUNTERPART SEE TE-PN: 2137740-X.
 - NOT FOR SALE, DESCRIBES ONLY THE MOUNTING STATE.
 - SPECIFIED WIRE RANGE: SEE TABLE.
- △ CODING AREA
 (A1) △ COMPONENTS OF WIRE SIZE: 35/50/95 MM² ARE NOT AVAILABLE NOW.

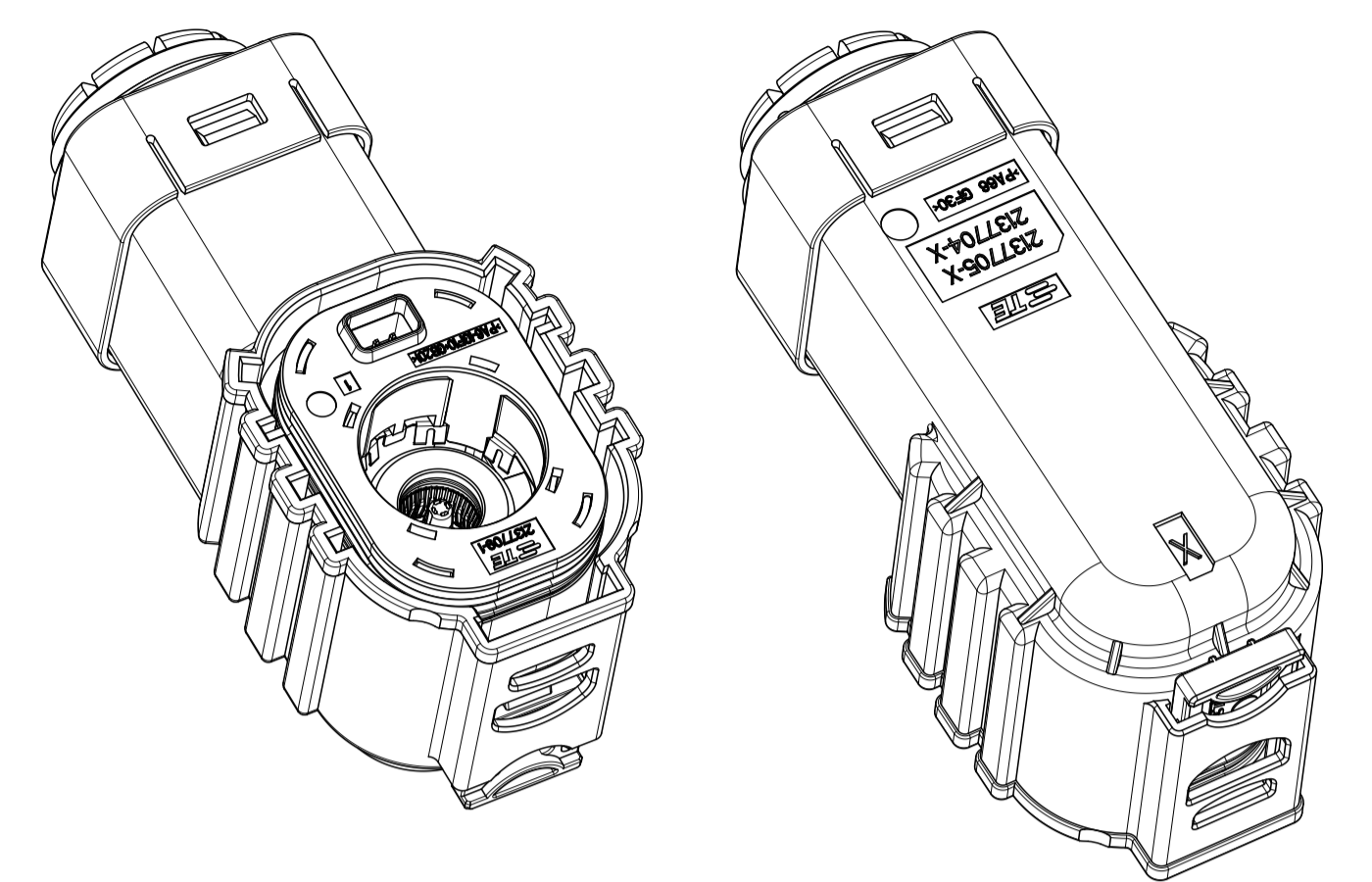
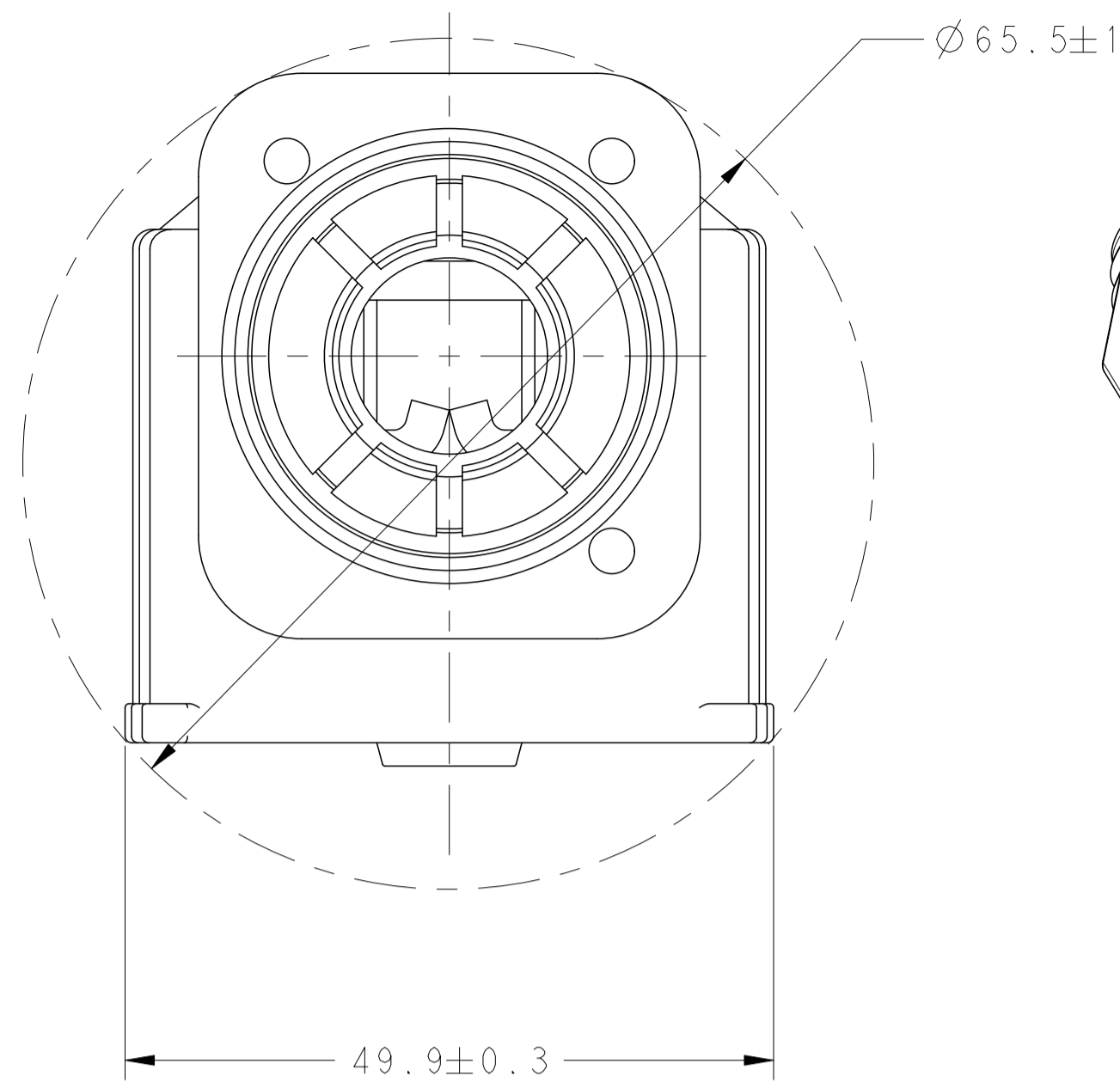
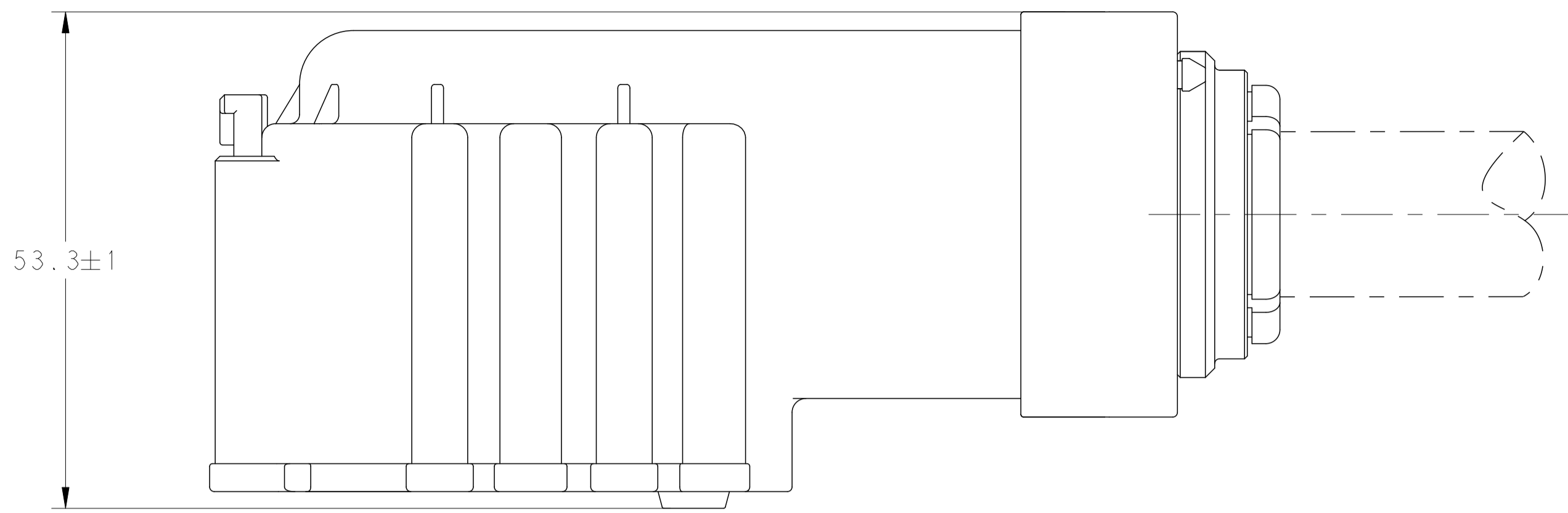
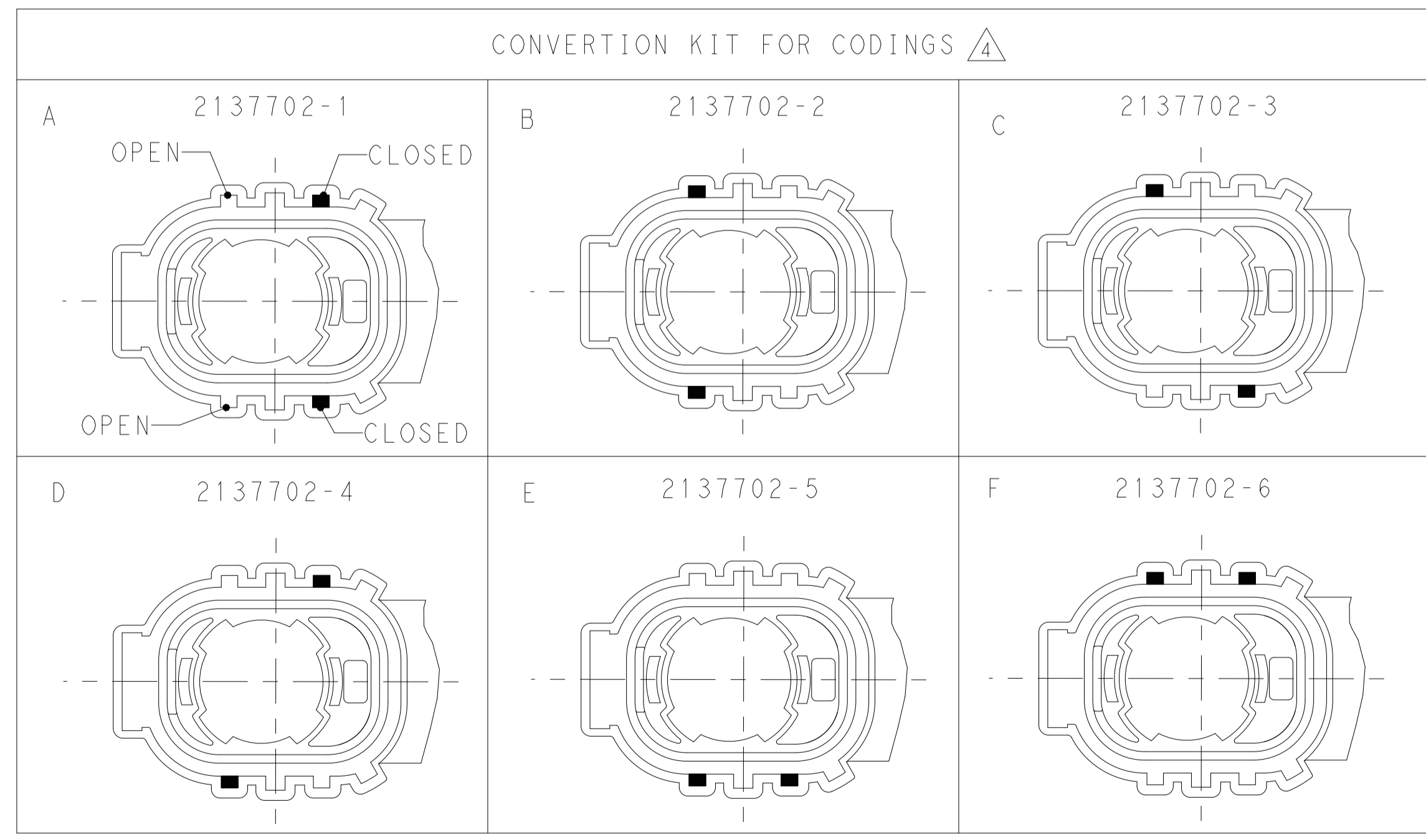
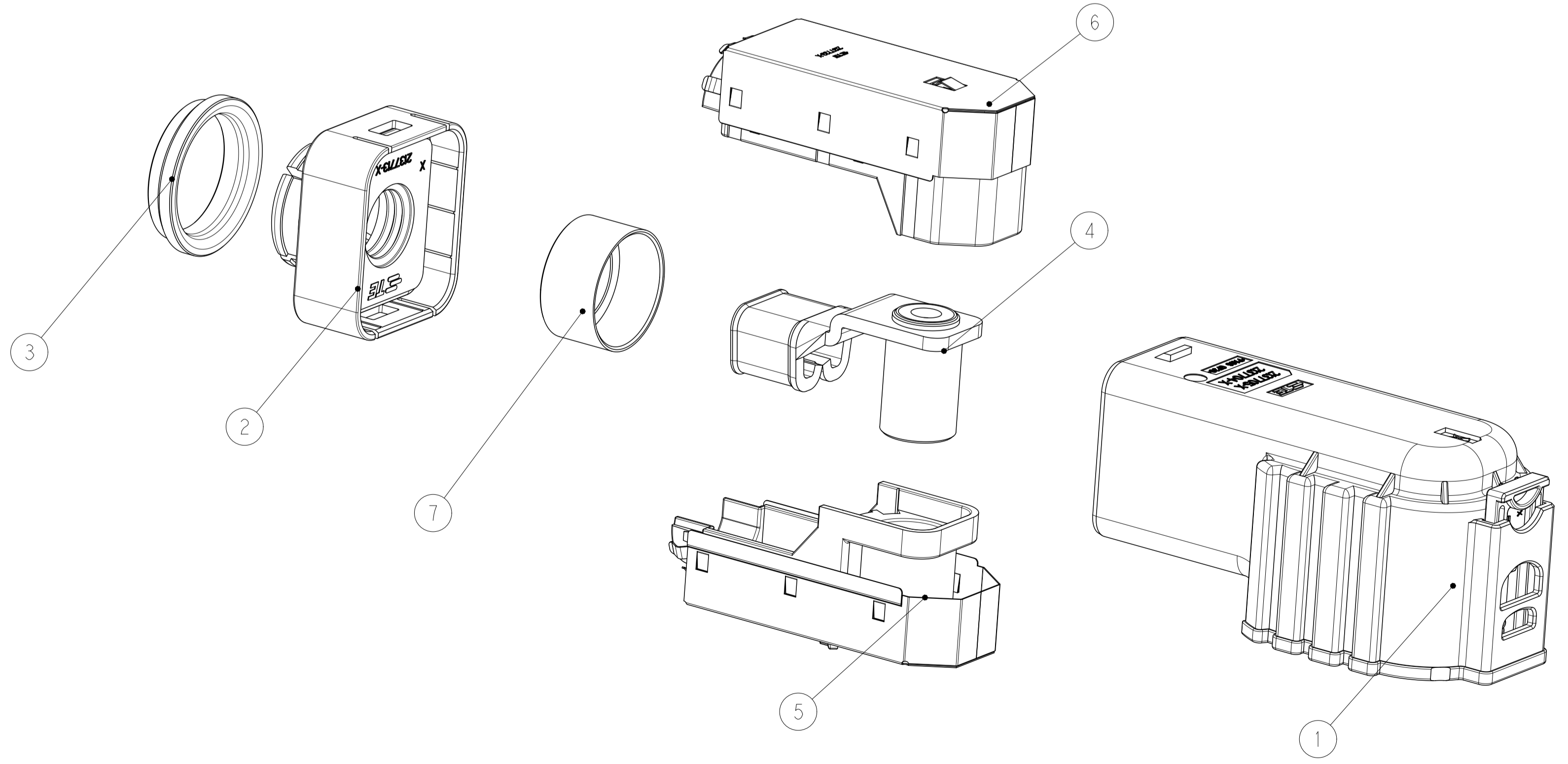

THIS DRAWING IS A CONTROLLED DOCUMENT.		DMN E. WANG 08NOV11	TE Connectivity NAME HV1100 1POS PLUG 90 DEG ASSY SLD
DIMENSIONS: mm		CHK N. ZHOU 08NOV11	
TOLERANCES UNLESS OTHERWISE SPECIFIED:		APVD K. QDA 08NOV11	PRODUCT SPEC 108-101010 (A1)
0 PLC ±0.5 1 PLC ±0.5 2 PLC ±0.13 3 PLC ±0.13 4 PLC ±0.001 ANGLES ±1°		APPLICATION SPEC 114-101010	SIZE A1
MATERIAL		WEIGHT	SCALE 2:1
FINISH		CUSTOMER DRAWING	SHEET 1 OF 2
			REV A1

LOC	DIST	REVISIONS					
ES	00	P	LYR	DESCRIPTION	DATE	DWN	APVD
		-		SEE SHEET 1		-	-

HV1100 1POS PLUG 90 DEG ASSY SLD	F	95mm ² ⚠️ (A1)	1						1														
	E									1													
	D				1						1				1				1				
	C					1						1				1							
	B					1						1											
	A						1	1															
	F	70mm ²	1																				
	E			1																			
	D				1						1								1				
	C					1						1											
	B					1						1											
	A						1	1															
	F	50mm ² ⚠️ (A1)	1																				
	E																						
	D				1														1				
	C					1							1										
B					1							1											
A						1	1																
F	35mm ² ⚠️ (A1)	1																					
E																							
D					1													1					
C						1							1										
B						1							1										
A							1	1															
DISCRIPTION	KEY	WIRE SIZE	OPTION(CODES)	-6	-5	-4	-3	-2	-1	-4	-3	-2	-1	-2	-1								
			DISCRIPTION	HV1100 1POS PLUG HSG SLD 90 DEG					CABLE SEAL ASSY					CABLE ENFORCE RING		TERMINAL GRID ASSY		LOWER INSERT ASSY		UPPER INSERT ASSY		SHIELDING FERRULE	
			TE-PART-NO	2137704-X					2137711-X					2137710-X		2137715-X		2137722-1		2137735-1		2209388-1	
			ITEM	1					2					3		4		5		6		7	

THIS DRAWING IS A CONTROLLED DOCUMENT.

DIMENSIONS:	TOLERANCES UNLESS OTHERWISE SPECIFIED:	DWN	E. WANG	08OCT11
mm	0 PLC ±0.5	CHK	N. ZHOU	08NOV11
	1 PLC ±0.3	APVD	K. QDA	08NOV11
	3 PLC ±0.13	NAME	HV1100 1POS PLUG 90 DEG ASSY SLD	
	4 PLC ±0.001	PRODUCT SPEC	(A1)	
	ANGLES ±1°	APPLICATION SPEC	108-101010	
MATERIAL	FINISH	114-101010	SIZE	CAGE CODE
		WEIGHT	A100779C=2137702	
		CUSTOMER DRAWING	SCALE	2:1
			SHEET	2 OF 2
			REV	A1

4805 (3/11)