

THIS DRAWING IS UNPUBLISHED. RELEASED FOR PUBLICATION  
 © COPYRIGHT - By - ALL RIGHTS RESERVED.

LOC		DIST		REVISIONS			
P	LTR	DESCRIPTION		DATE	DWN	APVD	
AF	50	J2	ECR-15-005665	10AUG2015	BDA	PKS	

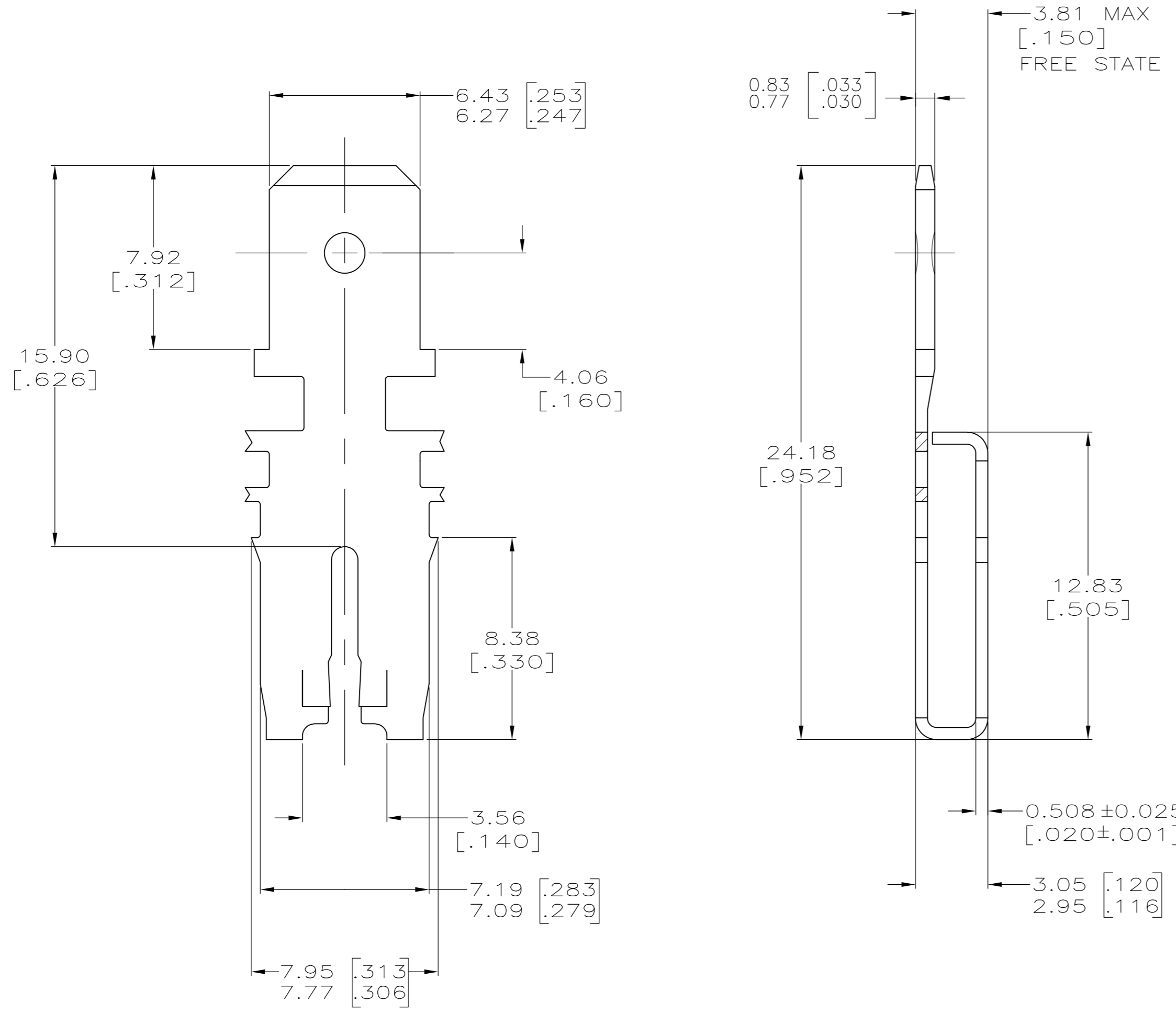

- CONTINUOUS STRIP ON REELS WITH TERMINALS LOCATED ON 8.38±0.08 [.330±.003] CENTERS.
- △ SLOT ACCEPTS 1.45-1.29mm DIA [#15-#16] AWG COPPER MAGNET WIRE.  
SLOT ACCEPTS 1.37-1.54mm DIA [#15.5-#14.5] AWG ALUMINUM MAGNET WIRE.  
ALUMINUM WIRE RANGE APPLIES FOR POST-TIN PLATED VERSIONS ONLY.TWO WIRES OF THE SAME SIZE MAX PER SLOT.
- AFTER INSERTION INTO PLASTIC HOLDER, TAB PORTION MUST BE BENT OVER 45° TO 90° OR POTTED-IN TO PREVENT PULL-OUT WHEN MATING RECEPTACLE IS DISCONNECTED.
- △ VARNISH RESIST OVER TIN PLATE.
- △ PRELIMINARY - NOT FOR PRODUCTION.

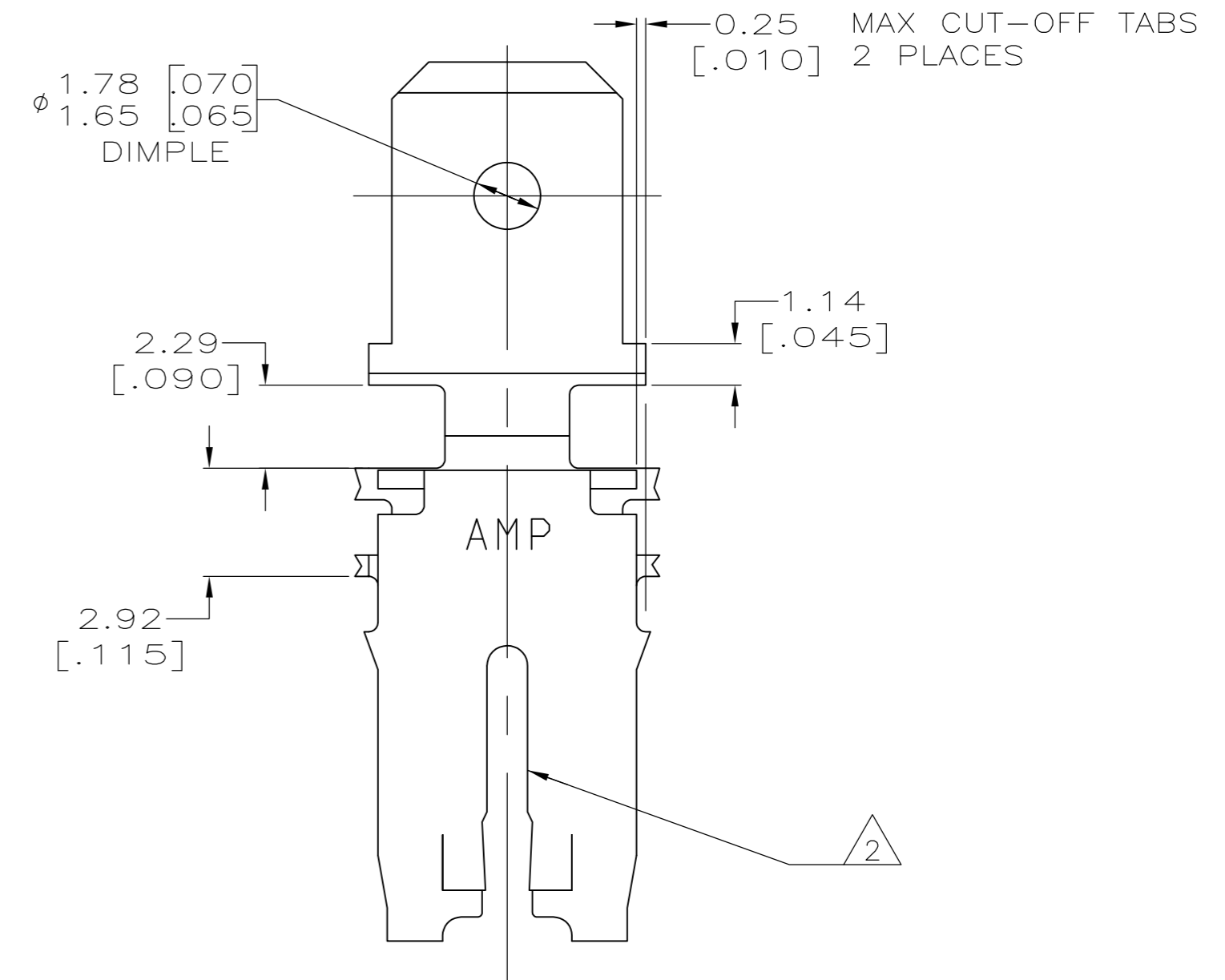

H04 PRE-MILLED PHOS BRONZE	△ 63064-2
4M PRE-MILLED BRASS	63064-1
MATERIAL	PART NUMBER

THIS DRAWING IS A CONTROLLED DOCUMENT.		DWN 07MAY1999 MICHAEL S. FEHER	<b>TE</b> TE Connectivity	
DIMENSIONS: mm [INCHES]		CHK 07JUN1999 JEFF R. RUTH		
TOLERANCES UNLESS OTHERWISE SPECIFIED:		APVD 07JUN1999 KURT A. RANDOLPH	NAME	
0 PLC ± -		PRODUCT SPEC	TAB, 6.35 [.250] FASTON, 500 SERIES MAG-MATE	
1 PLC ± -		108-2053	-	
2 PLC ± 0.25 [.010]		APPLICATION SPEC	SIZE	CAGE CODE
3 PLC ± -		114-2066	A2	00779
4 PLC ± -		WEIGHT	SCALE	DRAWING NO
4 ANGLES ± -		-	6:1	63064
FINISH		CUSTOMER DRAWING	SHEET	RESTRICTED TO
△ 4			1 of 1	-
SEE TABLE			REV	J2