

LEGEND

◆ = KEY PRODUCT CHARACTERISTICS

○ = CRITICAL INSPECTION DIMENSIONS

REVISION HISTORY					
REV	DESCRIPTION	BY	APP'D	DATE	ECN
1	FIRST ISSUED	MH	PM	10-08-16	----
2	CHANGE FROM MATT TO ZINC BLACK PLATING	MH	PM	10-08-16	9389

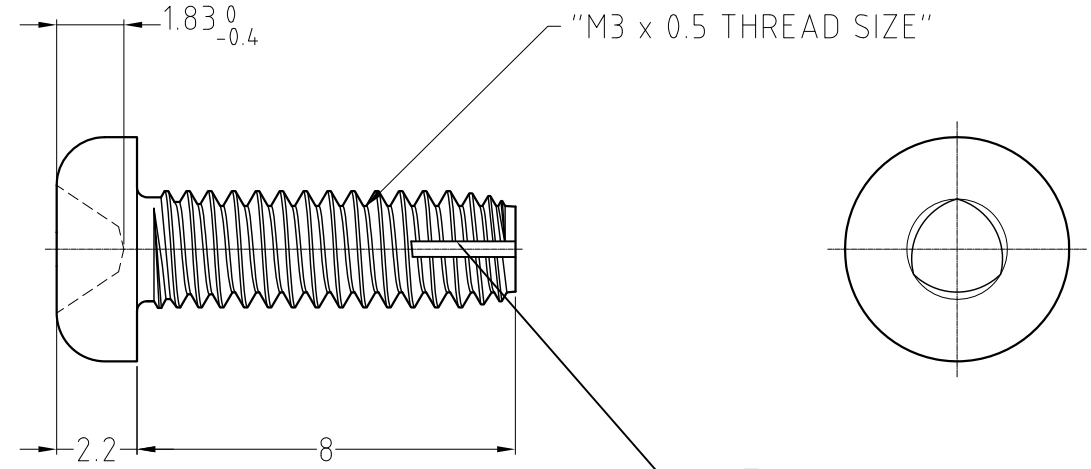
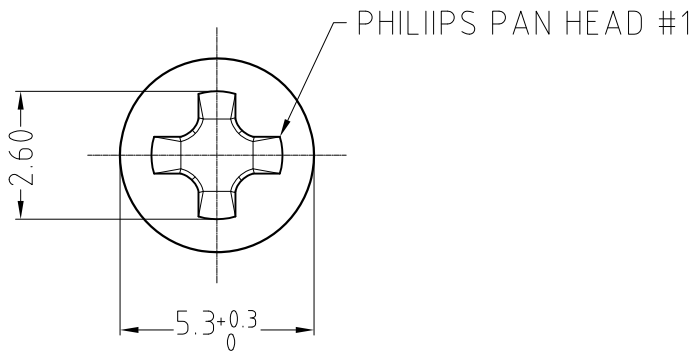

52500016-300	NICKEL PLATE
52500016-400	BLACK ZINC PLATING
PART NUMBER	FINISH

NOTE:  
 1.MATERIAL: CARBON STEEL C1018A.  
 PARTS TO BE HEAT TREATED TO HARDEN  
 TO HARDNESS OF 55 HRC

UNLESS OTHERWISE SPECIFIED TOLERANCE TO BE		THIS DOCUMENT IS THE PROPERTY OF AMPHENOL AUSTRALIA PTY. LTD.. NO PART THEREOF MAY BE REPRODUCED AND USED WITHOUT THE PRIOR WRITTEN CONSENT OF THE OWNER				<b>Amphenol</b> Amphenol Australia Pty Ltd 22 Industry Blvd Carrum Downs VIC 3201	
LINEAR	ANGULAR	MATL: CARBON STEEL SEE NOTE	DRN: MH	DATE: 10-08-16	TITLE: SCREW M3 x 0.5		PART No: SEE TABLE
X ± 0.5	X° ± 1°		CKD: MH	DATE: 05-12-16			DRAWING NO. 52500016-300-1
X,X ± 0.1	X°X' ± 30'	FINISH: REFER TABLE	APP'D: PM	DATE: 05-12-16	SCREW M3 x 0.5		
X,XX ± .N	X°X'X" ± 15'		SCALE: 5:1	SIZE: A4			
BREAK ALL SHARP EDGES AND REMOVE ALL BURRS		DIMENSIONS IN MILLIMETRES		THIRD ANGLE PROJECTION		CB4.17.F1	