

Mechanical Dimensions: Inches [mm]

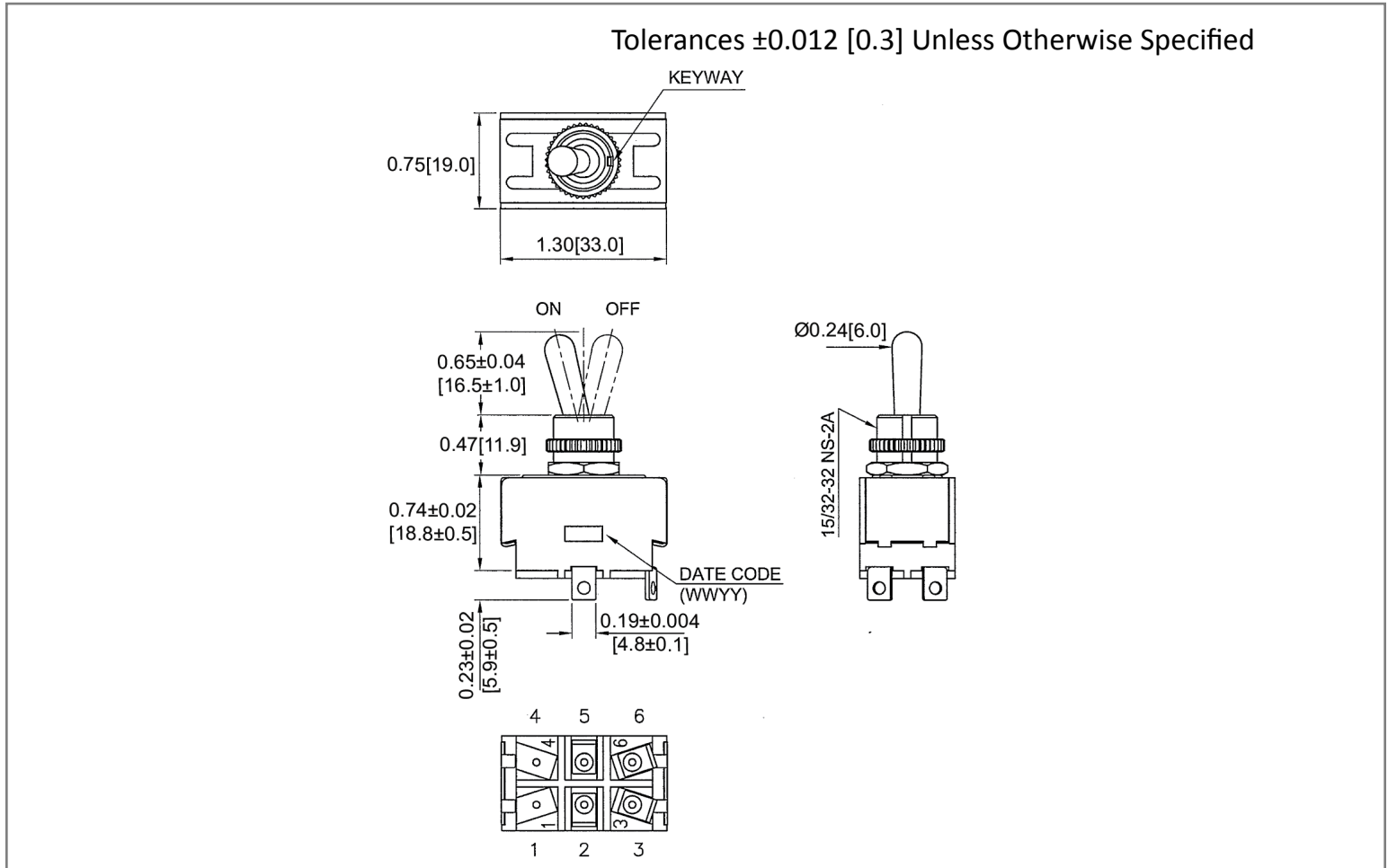

Mounting Hole

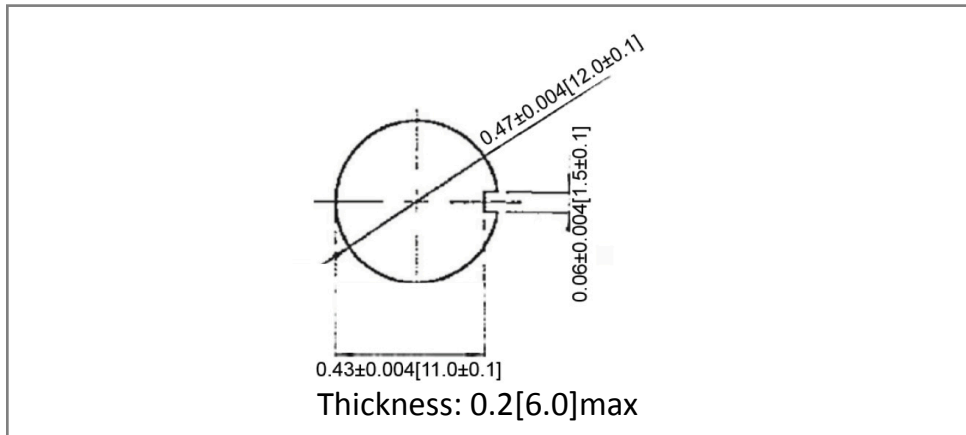

Circuit Diagram

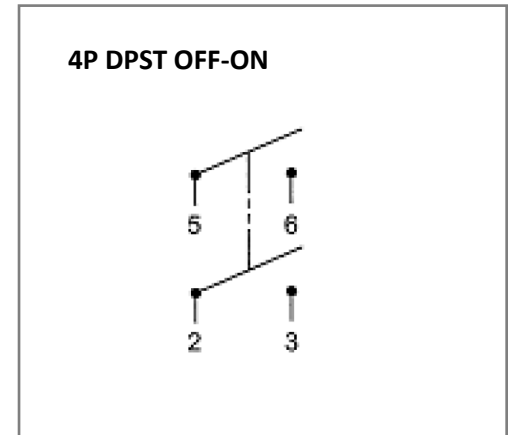

Electrical Specifications

Rating 10(4)A 125/250V AC, 10A 125/250V AC

20A 125V AC, 10A 277V AC, 1 1/2HP 125-250V AC

Contact Resistance 50m ohm Max

Insulation Resistance DC 500V 100M ohm Min.

Dielectric Strength AC 1500V 1 minute

Operation Temperature 1200gf ± 300 gf

Material Specifications

1 HEX NUT ASSY

1 KNURL NUT

Rev	Date of issue	Revision Notes	Designed	Approved
A	05-13-2021	Initial Drawing	RC	OF