

**PC712A**

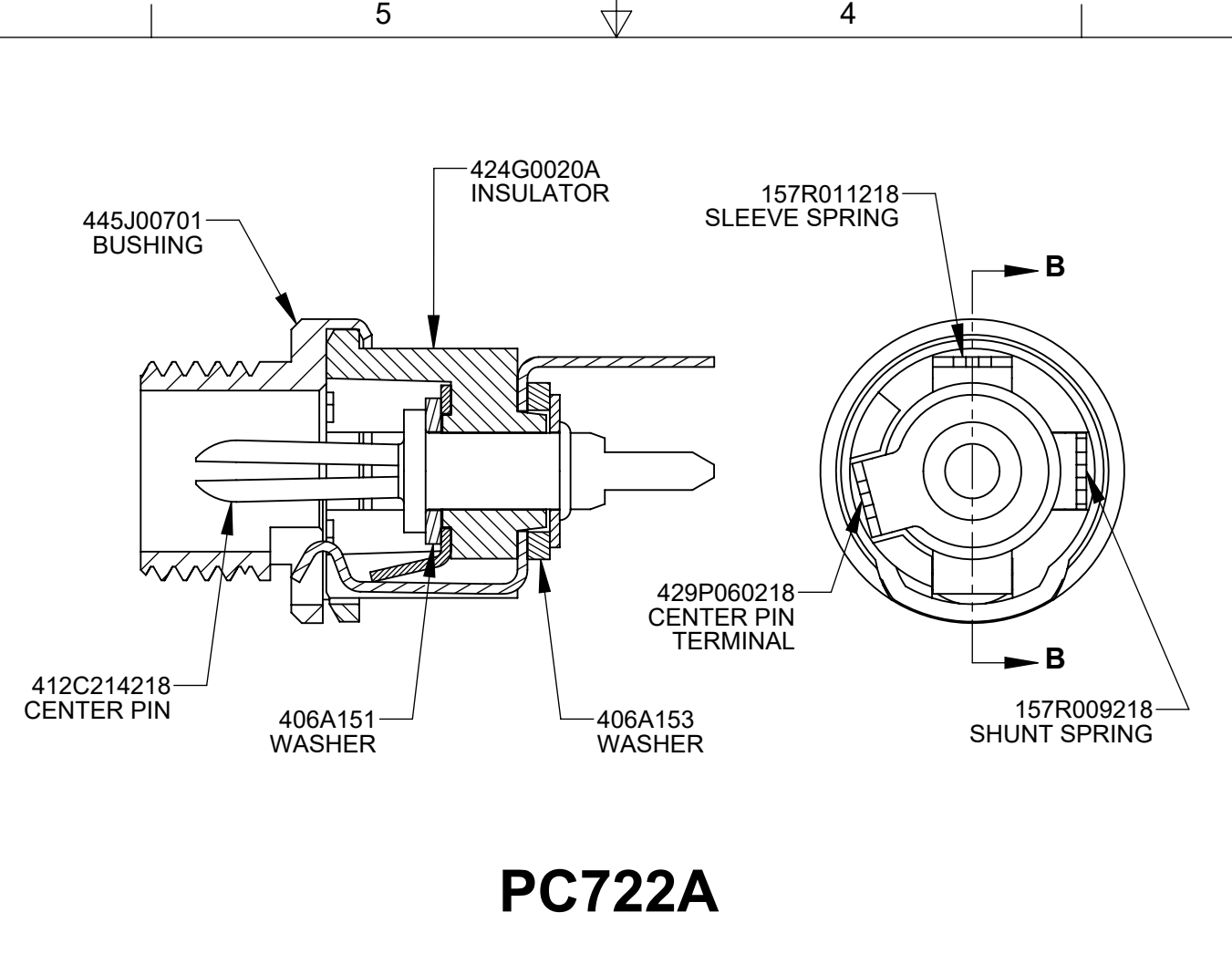

**PC722A**

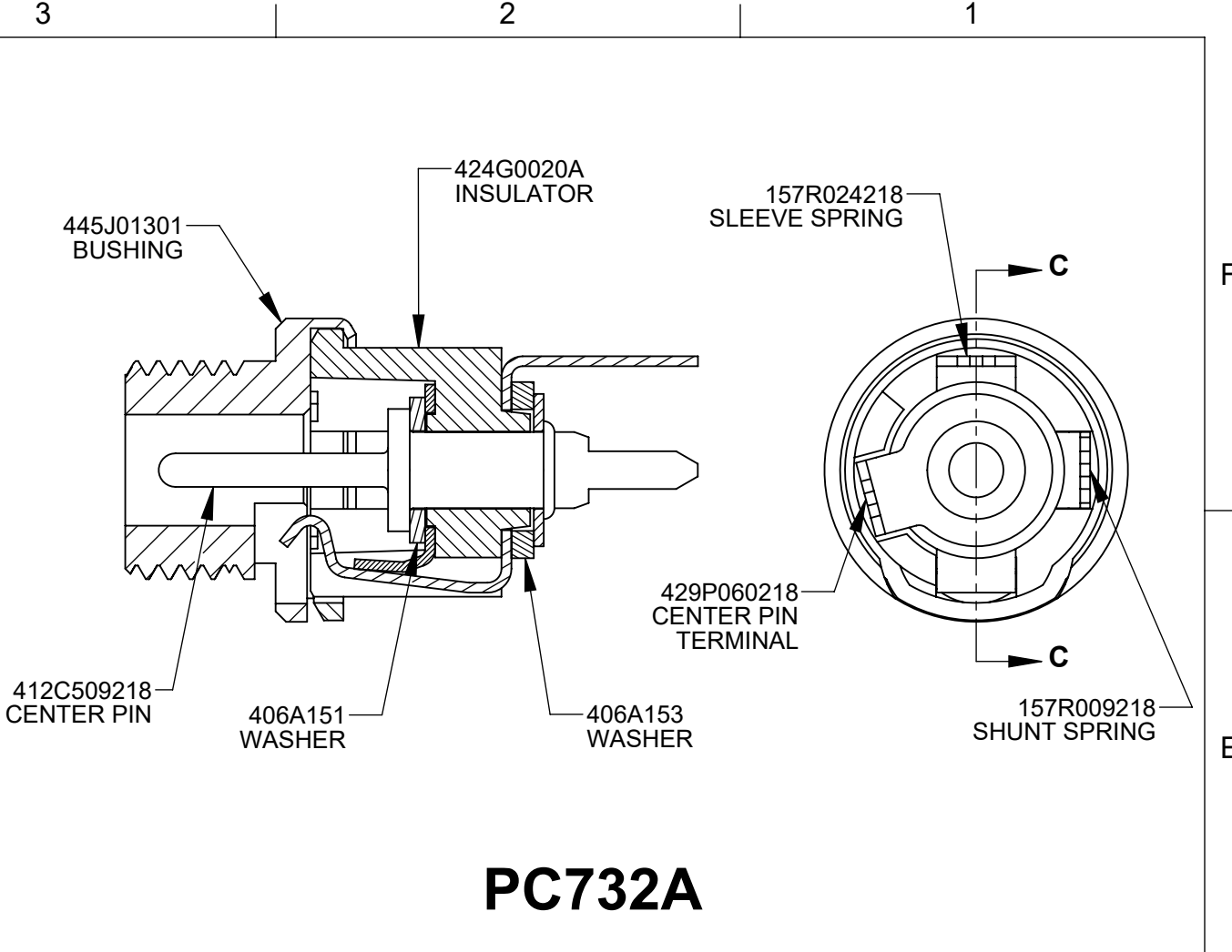

**PC732A**

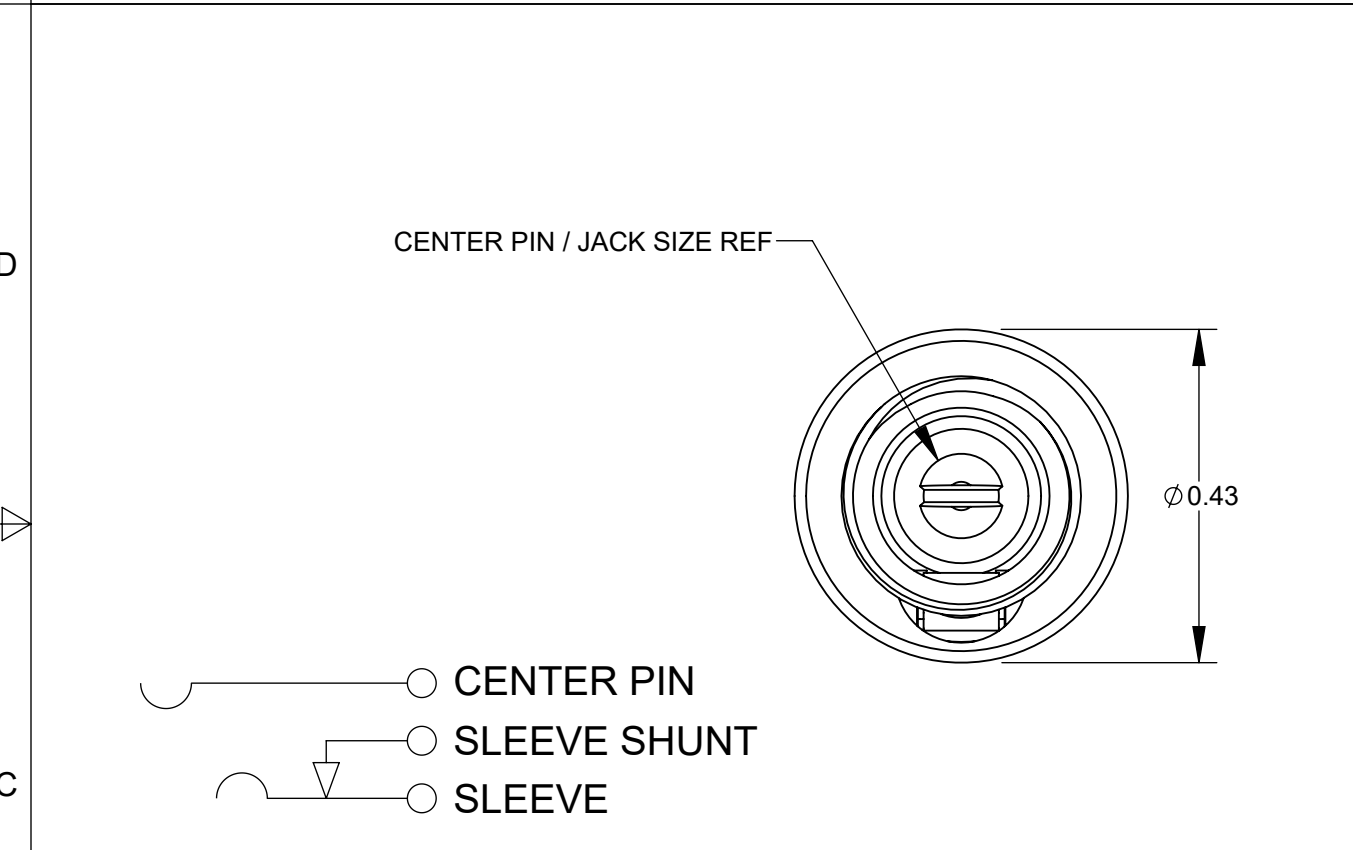

**SCHEMATIC**

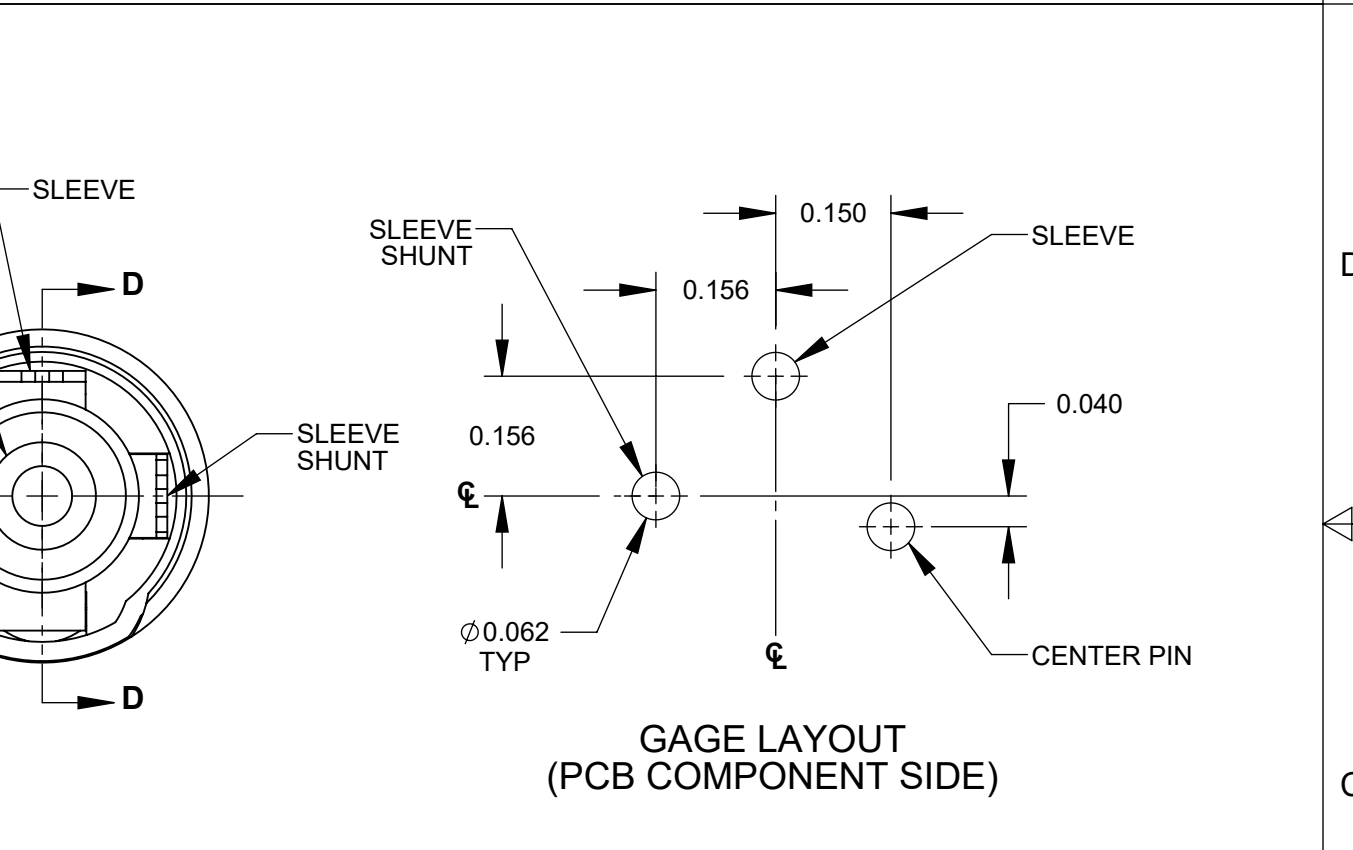
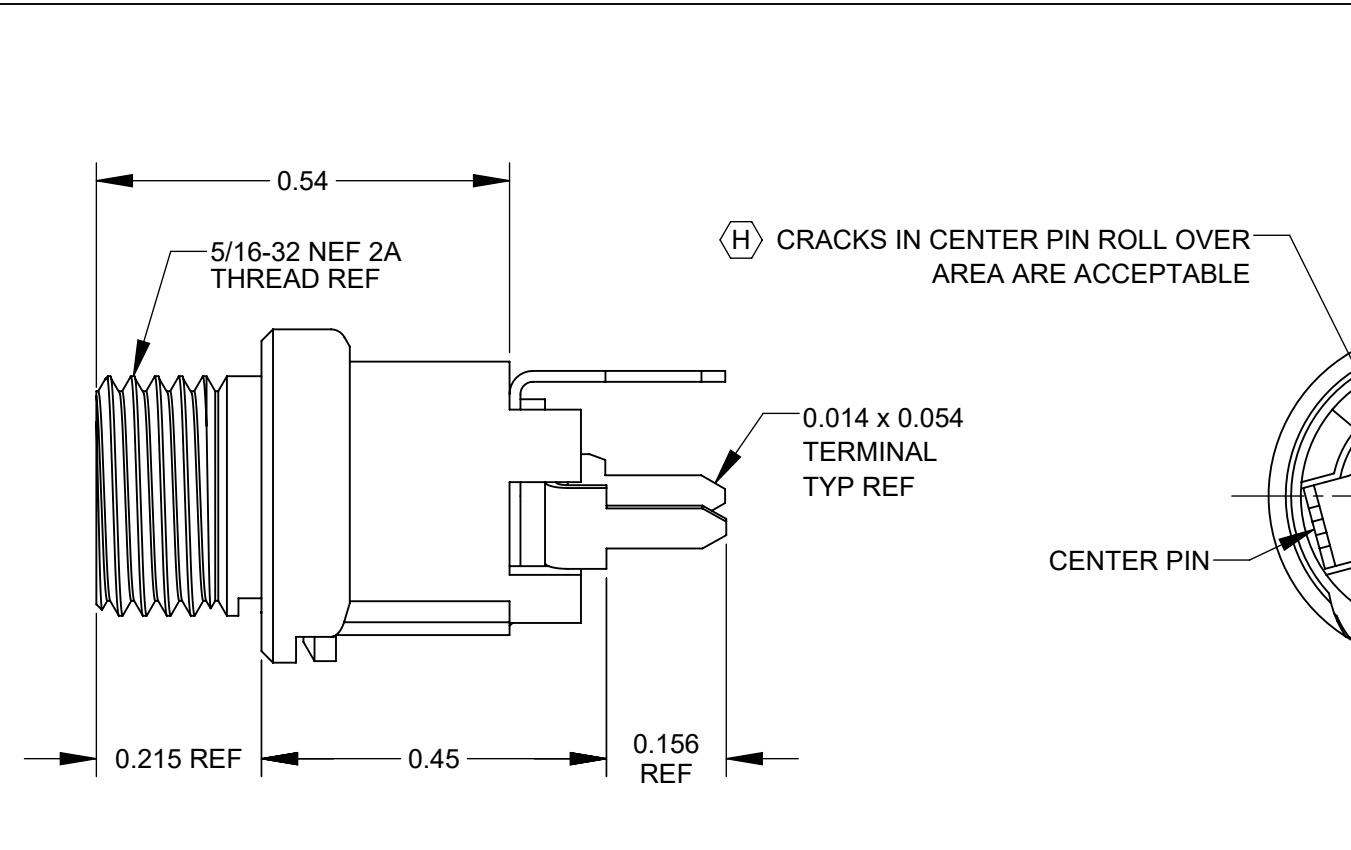

**NOTES:**

- (a) CONTINUITY CHECK (E-1103-1) TEST SET  
CHECK TRANSFER OF CONTINUITY BETWEEN JACK SLEEVE AND SHUNT TO THE JACK SLEEVE AND PLUG GAGE WITH THE INSERTION OF PLUG GAGE M518-01.
- (b) BUSHING I.D. / TIP POSITION CHECK  
CHECK BUSHING I.D. AND SLEEVE SPRING TIP POSITION WITH M518-02 PLUG GAGE.
- DIELECTRIC CHECK  
CHECK FOR DIELECTRIC STRENGTH OF 500 VAC MINIMUM BETWEEN SLEEVE AND SHUNT WITH PLUG GAGE INSERTED.
- INSERTION AND WITHDRAWAL FORCE  
INSERTION FORCE: 3 LB MAX.  
WITHDRAWAL FORCE: 4 OZ. MIN.
- FORCE TO OPEN SHUNT-APPLIED AT THE POINT "X" OF THE SLEEVE SPRING.  
USING M578 FORCE GAGE.  
MINIMUM FORCE: 125 GRAMS
- FREQUENCY OF IN-PROCESS CHECKS BY PRODUCTION ON A PERCENTAGE BASIS:  
NOTE 1 (a) : 100%  
NOTE 1 (b) : 5%  
NOTE 4 : 1%
- HEX NUT AND FLAT WASHER SHIPPED UNASSEMBLED.
- THESE ASSEMBLIES ARE RoHS COMPLIANT.

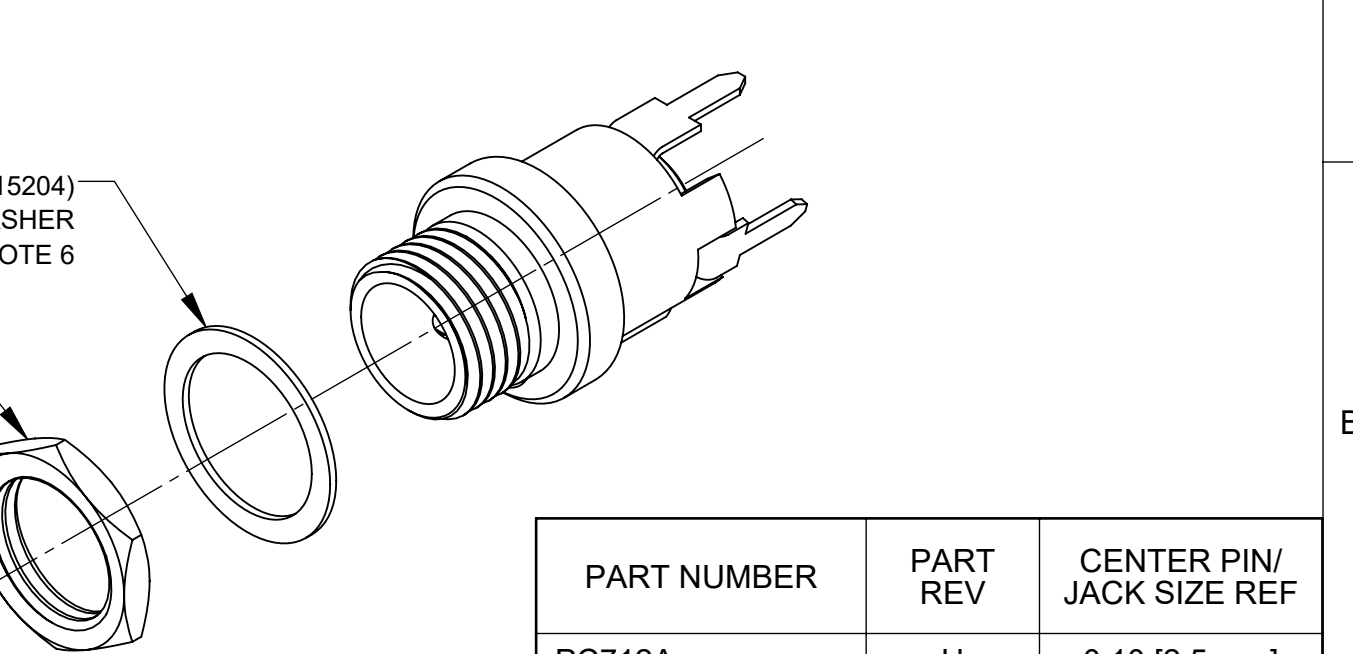
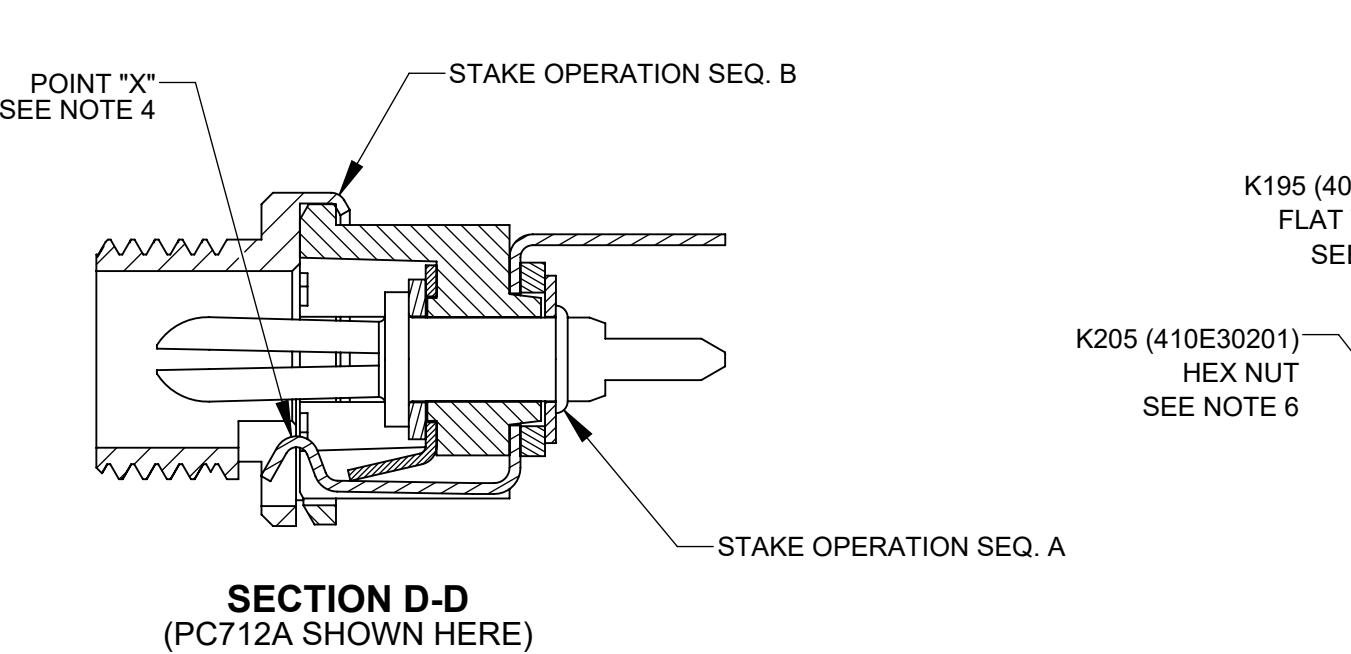

PART NUMBER	PART REV	CENTER PIN/JACK SIZE REF
PC712A	H	0.10 [2.5 mm]
PC722A	H	0.080 [2.0 mm]
PC732A	H	0.05 [1.3 mm]

☆ STAR SYMBOL DENOTES CRITICAL DIMENSION UNLESS OTHERWISE SPECIFIED 1. ALL DIMENSIONS IN INCHES - TWO PLACE DECIMALS ±0.01 - THREE PLACE DECIMALS ±0.005 - ANGLES ±1° - ALL DIA. CONCENTRIC WITHIN 0.005 T.I.R. 2. FEATURES ON THE SAME CENTERLINE MUST BE ALIGNED WITHIN ±0.002 3. REMOVE ALL BURRS				THIS DRAWING DESCRIBES A DESIGN CONSIDERED PROPRIETARY IN NATURE, DEVELOPED AND MANUFACTURED BY SWITCHCRAFT INC. AND IS RELEASED ON A CONFIDENTIAL BASIS FOR IDENTIFICATION PURPOSES ONLY.			
SIZE	WIDTH	MULT	LBS/M	TEMPER	MATERIAL SPEC No.		
FINISH SPEC No.			SCALE 4:1				
DATE DRAWN	BY	CHKD	APVD	FIRST USED ON			
07/09/21	PC	PC	PC	07/09/21	07/09/21	SHEET 1 OF 1	
NAME POWER JACKS STRAIGHT PC, RoHS				PART No. PC712A PC722A PC732A		REV H	
REVISIONS				DO NOT SCALE DRAWING			