

PART NUMBER	REVISION	DESCRIPTION	FEED TYPE
2151261-1	C	FINE CRIMP HEIGHT ADJUST	MECHANICAL
2151261-2	D	FINE CRIMP HEIGHT ADJUST	PNEUMATIC
7-2151261-1	C	MECHANICAL AND CRIMP TOOLING KIT	MECHANICAL
7-2151261-2	D	PNEUMATIC AND CRIMP TOOLING KIT	PNEUMATIC
7-2151261-7	A	CRIMP TOOLING KIT	-

ATLANTIC VERSION TERMINATOR INTERFACE ADAPTER

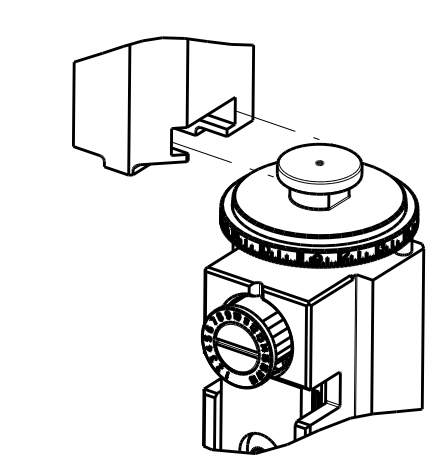

APPLICATOR DATA		
CRIMP	SIZE	TYPE
WIRE	2.29 mm [.090]	F
INSUL	3.56 mm [.140]	F

APPLICATOR INSTRUCTIONS  
408-35042

TERMINAL DATA: TE TERMINAL		TE CRIMP SPECIFICATION	
TERMINAL NAME: STANDARD TIMER CONTACT			
WIRE STRIP LENGTH		INSULATION DIAMETER RANGE	
4.30-4.90 mm [.169-.193 IN]		Ø2.00-3.00 mm [.079-.118 IN]	
TERMINAL APPLICATION SPECIFICATION	114-18080		
TERMINALS APPLIED			
TE TERMINAL	TE TERMINAL	TE TERMINAL	TE TERMINAL
925575-1	925575-2	3-925575-1	3-925575-2

TERMINAL DATA: TE TERMINAL		TE CRIMP SPECIFICATION	
TERMINAL NAME: STANDARD TIMER CONTACT			
WIRE STRIP LENGTH		INSULATION DIAMETER RANGE	
4.30-4.90 mm [.169-.193 IN]		Ø2.00-3.00 mm [.079-.118 IN]	
TERMINAL APPLICATION SPECIFICATION	114-18080		
TERMINALS APPLIED			
TE TERMINAL	TE TERMINAL	TE TERMINAL	TE TERMINAL
926965-1	926965-2	3-926965-1	969036-4

WIRE SIZE	CRIMP HEIGHT mm [INCH]	CRIMP HEIGHT REFERENCE SETTING
1.50mm2	1.44+/-0.05 [.057+/-0.002]	9.7
1.00mm2	1.38+/-0.05 [.054+/-0.002]	10.3

WIRE SIZE	CRIMP HEIGHT mm [INCH]	CRIMP HEIGHT REFERENCE SETTING
1.50mm2	1.44+/-0.05 [.057+/-0.002]	9.7
1.25mm2	1.41+/-0.05 [.056+/-0.002]	10.0
1.00mm2	1.38+/-0.05 [.054+/-0.002]	10.3
0.75mm2	1.34+/-0.05 [.053+/-0.002]	10.7
0.50mm2	1.30+/-0.05 [.051+/-0.002]	11.1

- RECOMMENDED SPARE PARTS
- REFER TO SUPPLIED INSTRUCTION SHEET FOR CLEANING, LUBRICATION AND STORAGE OF APPLICATOR.
- APPLY PART NUMBER 2-23419-6 LOCTITE TO THREADS OF ITEM 242.
- CRIMP HEIGHT REFERENCE SETTING WAS THE SETTING USED WHEN THE APPLICATOR WAS QUALIFIED AT THE FACTORY. ADJUSTMENT MAY BE NECESSARY WHEN RUNNING APPLICATOR IN THE FIELD.
- 5. UNLESS SPECIFIED OTHERWISE TORQUE VALUES SHALL BE USED PER DOCUMENT, 101-35000.

**\*WARNING**  
ON INSTALLATION, SET WIRE DISC TO CRIMP HEIGHT REFERENCE SETTING FOR LARGEST WIRE SIZE. CRIMP HEIGHT REFERENCE SETTINGS GREATER THAN THE VALUE SHOWN MAY CAUSE DAMAGE TO THE CRIMP TOOLING. REFER TO THE INSTRUCTION SHEET FOR PROPER SETUP AND ADJUSTMENTS.

LOC	DIST	REVISIONS			
A	66	REV	DATE	BY	APPV
		B	ECR-13-008460	23MAY2013	X.Z T.E
		B1	ECR-17-015961	30OCT2017	KH JDG
		C	ECR-18-008119	26MAY2018	TB JDG
		D	ECR-20-016831	26NOV2020	FZ TE

-	1	-	1	-	2119641-1	FEED CAM, AIR FEED	248
-	1	1	1	1	2119082-9	CAM, SNAIL, INSULATION ADJUSTMENT	244
-	1	1	1	1	2079764-1	WASHER, WAVE SPRING, CREST-TO-CREST	243
-	1	1	1	1	2119083-1	RETAINER, INSULATION DIAL	242
-	1	1	1	1	18023-1	SCR, SKT HD CAP M3 X 5.0	241
-	-	1	-	-	2119580-1	MECHANICAL FEED ASSEMBLY	239
-	1	-	1	-	2844940-1	AIR FEED MODULE	238
-	REF	REF	REF	REF	994970-2	COUNTER, MAGNETIC	164
-	1	1	1	1	1-18028-2	WASHER, FLAT, REG M4	119
-	1	1	1	1	2844908-1	SCREW, LOCKING	99
-	1	1	1	1	2844907-1	POST, LOCKING	98
-	1	1	1	1	455888-4	SPACER, CRIMPER	82
-	1	1	1	1	1803607-3	DOCUMENTATION PACKAGE	71
-	1	1	1	1	2119740-1	TAG IDENTIFICATION	67
-	2	2	2	2	2168078-1	SCREW, DRIVE, RH, RoHS, 2 x .188	66
-	1	1	1	1	2168083-2	SCR, SKT HD CAP, RoHS, M4 X 8.0	60
-	1	1	1	1	5-18022-5	SCR, HEX HD CAP, M4 X 6.0	59
-	1	1	1	1	1338685-1	PAWL, FEED	56
-	4	4	4	4	2168083-3	SCR, SKT HD CAP, RoHS, M4 X 12.0	54
-	2	2	2	2	2168083-3	SCR, SKT HD CAP, RoHS, M4 X 12.0	53
-	1	1	1	1	1803382-6	HOLD DOWN, SPRING LOADED	50
-	1	2	1	2	18023-9	SCR, SKT HD CAP M4 X 6.0	49
-	-	1	-	-	2119652-1	FEED CAM, PRE FEED	48
-	-	1	-	-	2119653-1	FEED CAM, POST FEED	47
-	1	1	1	1	1803583-9	APPLICATOR BASIC ASSEMBLY, SF	46
-	1	1	1	1	1803515-1	RAM ASSEMBLY, SF ATLANTIC	44
-	1	1	1	1	1803602-1	SCR, BHSC, RoHS (M8 X 25)	41
-	1	1	1	1	1752356-3	SUPPORT, TERMINAL	34
-	2	2	2	2	2079383-5	SCR, BHSC, RoHS (M4 X 20)	33
-	2	2	2	2	2-2844962-6	SPACER, CYLINDRICAL, STRIP GUIDE	30
-	1	1	1	1	2844992-1	ASSEMBLY, STRIP GUIDE	29
-	1	1	1	1	1-455888-0	SPACER, CRIMPER	28
-	1	1	1	1	1320928-2	STRIP GUIDE	24
-	1	1	1	1	2168083-2	SCR, SKT HD CAP, RoHS, M4 X 8.0	21
-	1	1	1	1	1-18028-2	WASHER, FLAT, REG M4	20
-	1	1	1	1	2119533-1	STRIPPER, SIDE FEED	19
-	1	1	1	1	2119806-1	INSERT, SHEAR	13
-	1	1	1	1	3-22280-3	SPRING, COMPRESSION	12
-	1	1	1	1	1-356885-4	STOP, SHEAR	11
-	1	1	1	1	2119805-1	SHEAR HOLDER, FRONT	10
-	1	1	1	1	454276-5	FLOATING SHEAR, FRONT	9
-	1	2	2	1	1333205-1	ANVIL, COMBINATION	8
-	1	1	1	1	1-240641-3	SPACER	7
-	1	1	1	1	2119757-4	DEPRESSOR, SHEAR	5
-	1	1	1	1	238011-8	BLOCK, CRIMPER SPACER	4
-	1	2	2	1	2-2119582-4	CRIMPER, INSULATION F PREMIUM	3
-	1	1	1	1	455888-6	SPACER, CRIMPER	2
-	1	2	2	1	3-456406-0	CRIMPER, WIRE PREMIUM	1

**ATLANTIC VERSION**  
Shown on sheets 1 of 4 & 2 of 4  
(Pacific version shown on sheets 3 of 4 & 4 of 4)

DIMENSIONS:		TOLERANCES UNLESS OTHERWISE SPECIFIED:		MATERIAL:		FINISH:	
mm	0 PLC ±	1 PLC ±	2 PLC ±	3 PLC ±	4 PLC ±	ANGLES	

OWN	L. ZHANG	17OCT2011
CHK	L. ZHANG	17OCT2011
APPV	S. XI	17OCT2011
PRODUCT SPEC		
APPLICATION SPEC		
SIZE	CAGE CODE	DRAWING NO
A1	00779	2151261
Customer Accessible Production Drawing		SCALE 1:2 SHEET 1 OF 4 REV D

LOC		DIST		REVISIONS			
NO.	REV.	DATE	BY	DESCRIPTION	DATE	BY	APPROV.
A	66	-	-	SEE SHEET 1	-	-	-

# FEED TYPE MECHANICAL

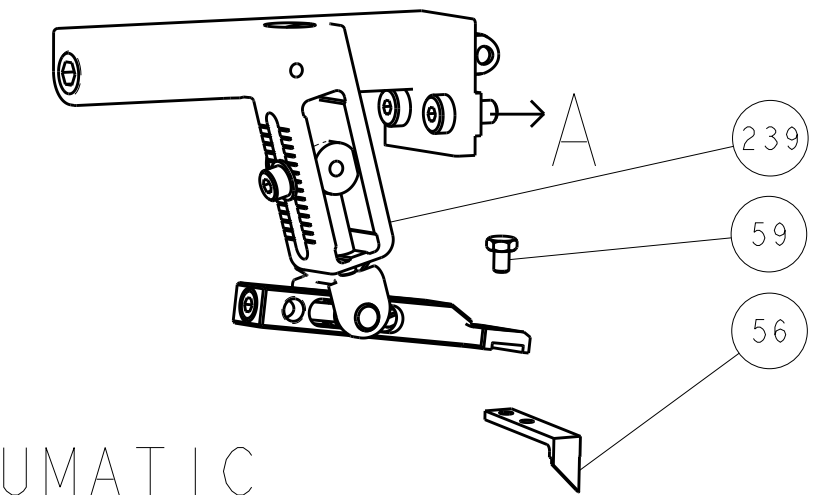

## PNEUMATIC

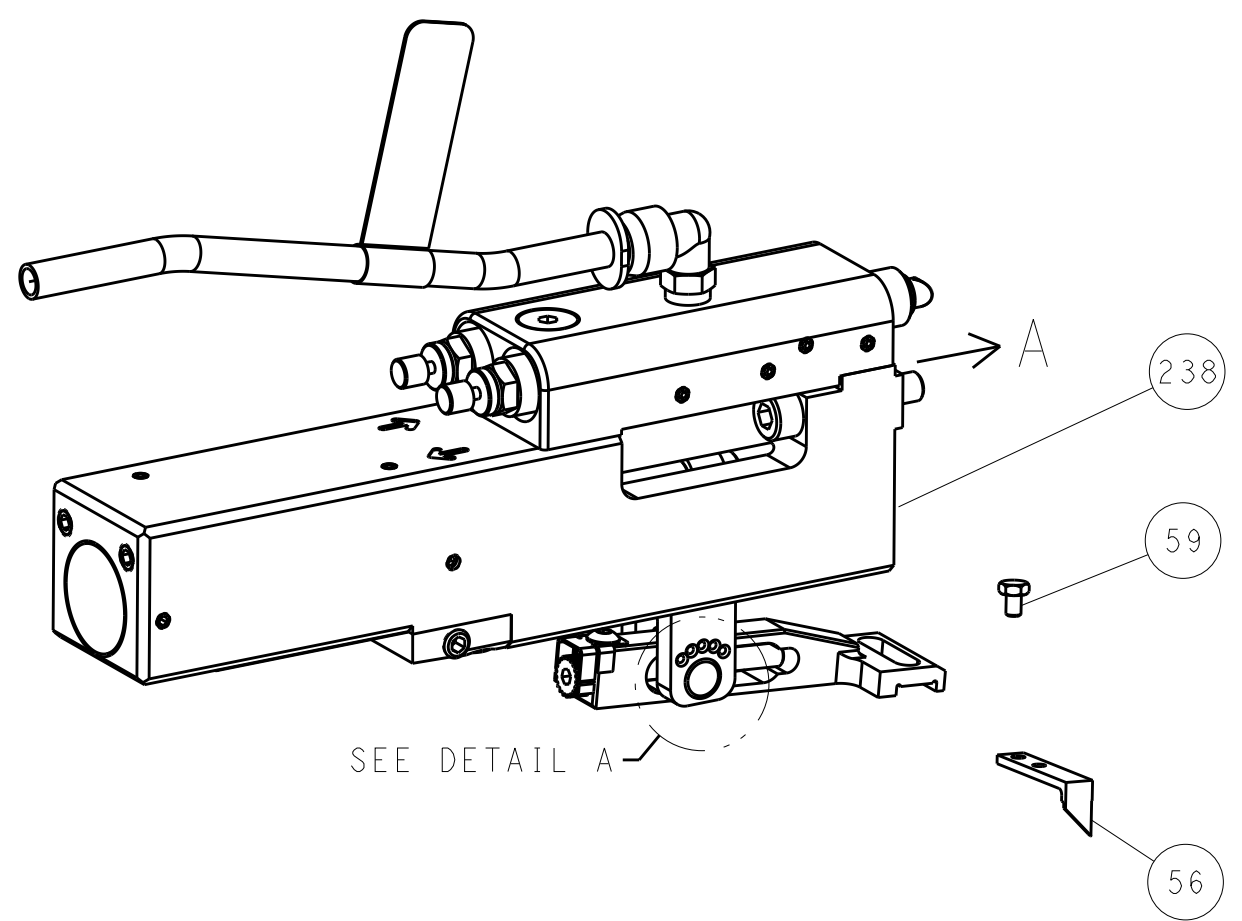

## FEED SPRING SETTING POSITION (SHOWN FROM REAR SIDE)

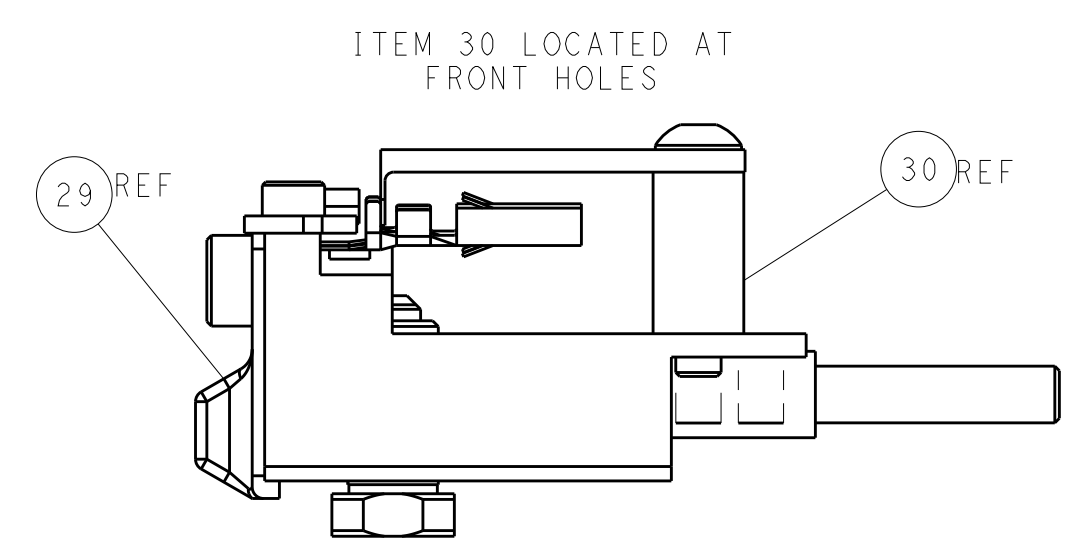
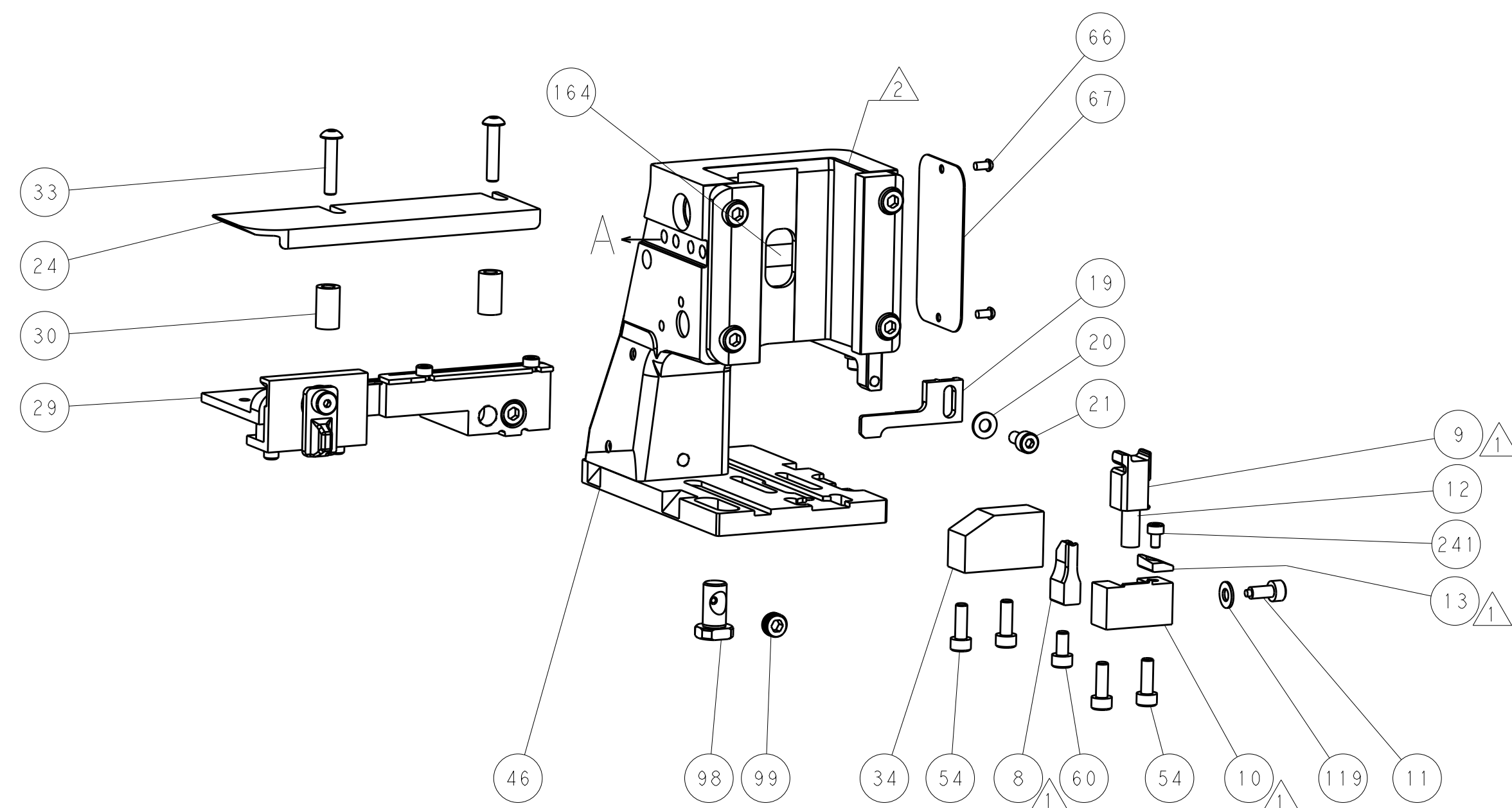
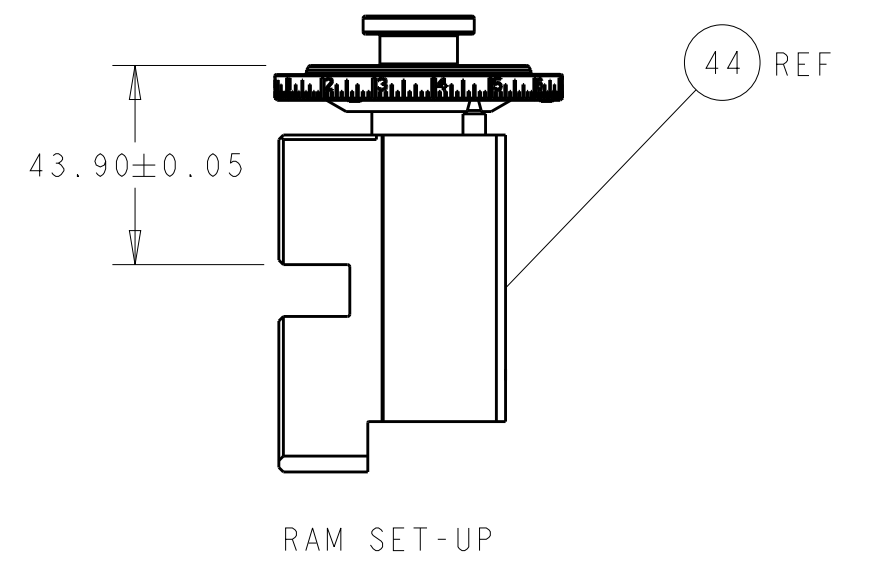
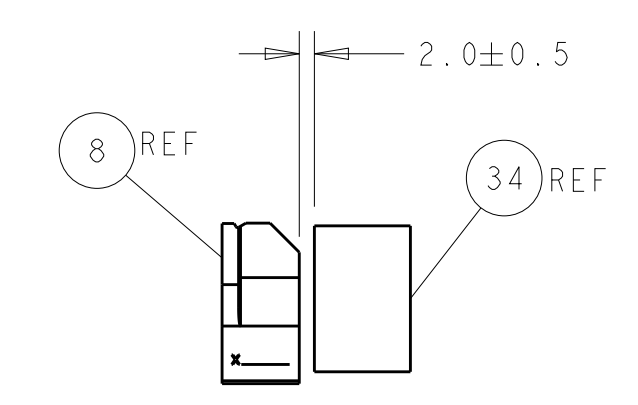
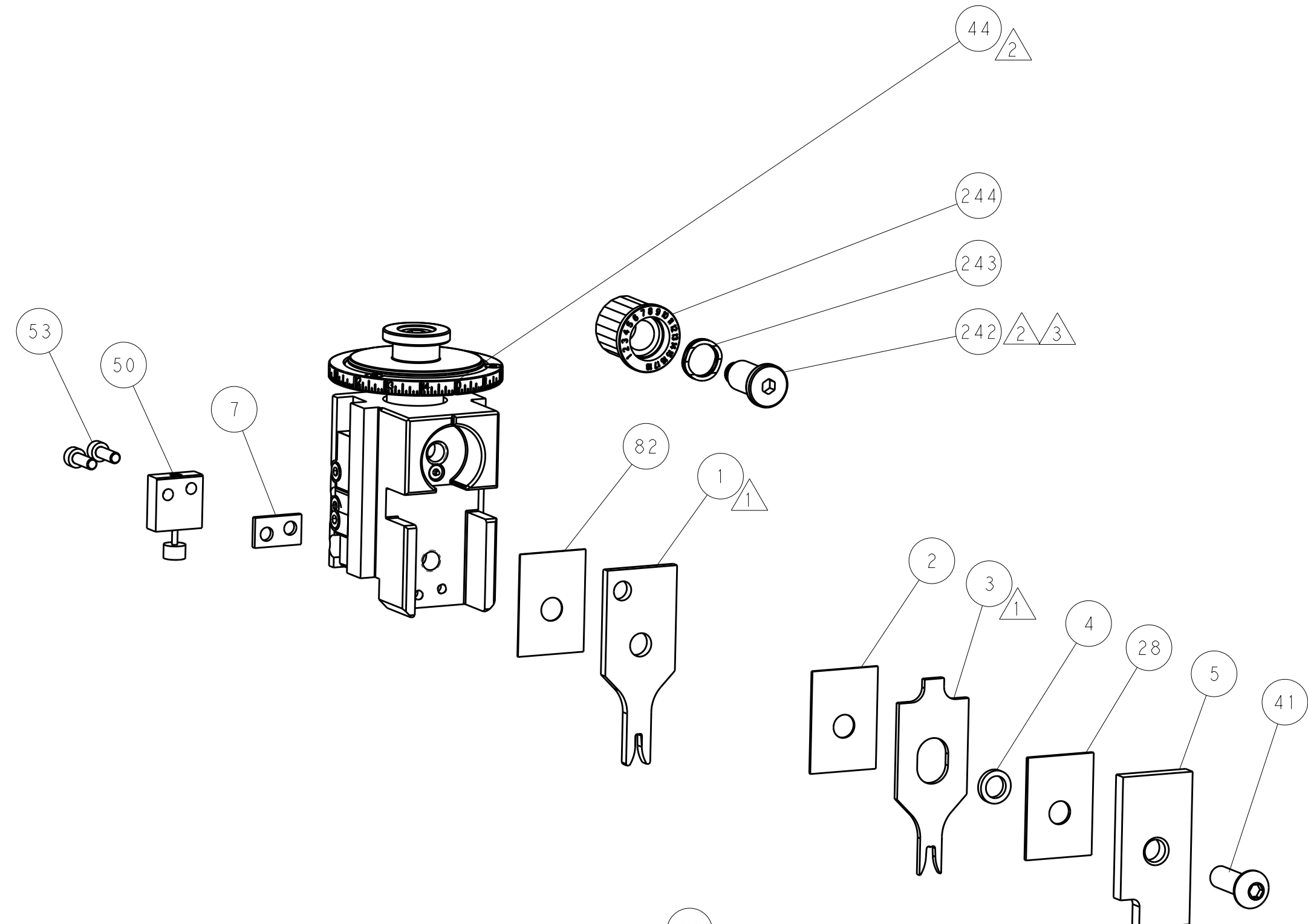
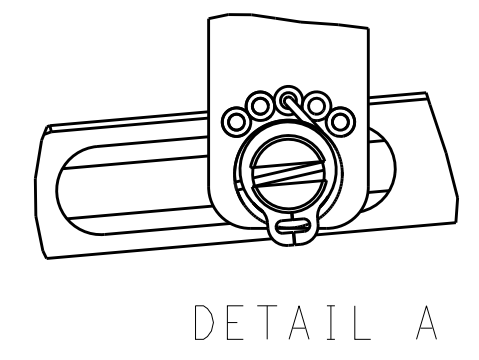

# CAM POSITIONS

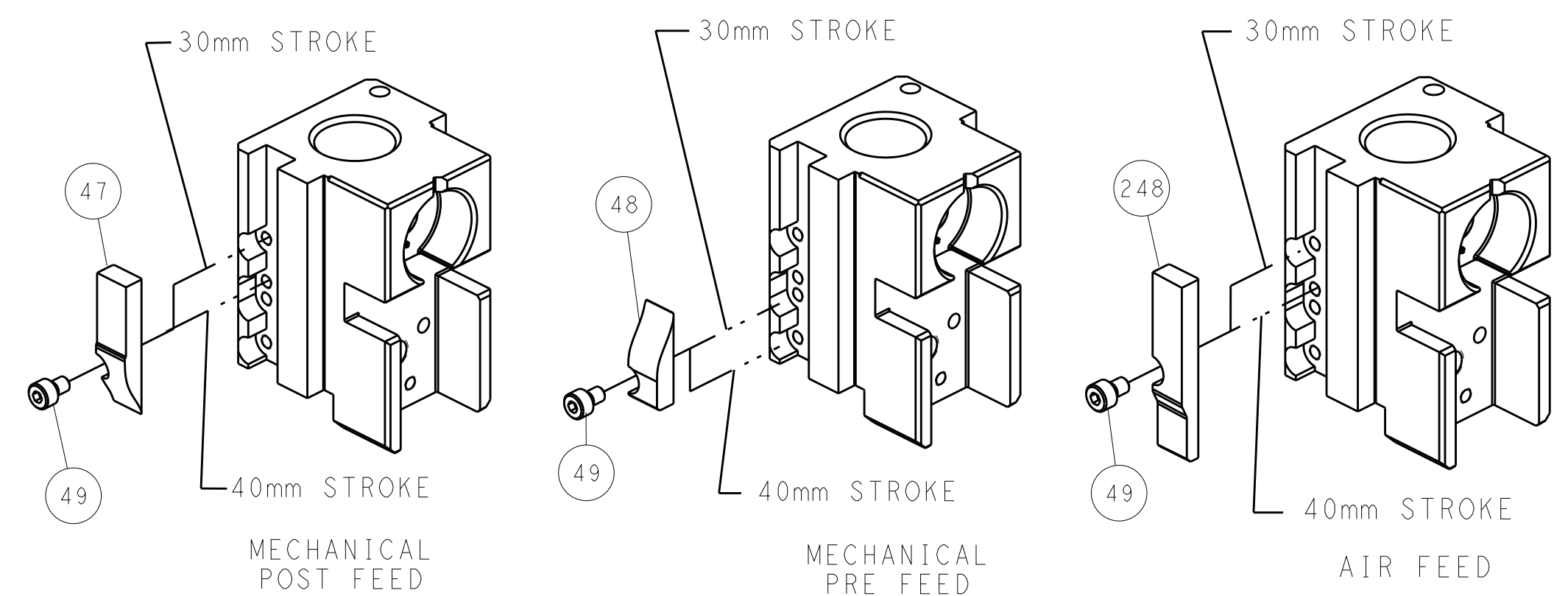

**ATLANTIC VERSION**  
 Shown on sheets 1 of 4 & 2 of 4  
 (Pacific version shown on sheets 3 of 4 & 4 of 4)

DIMENSIONS:		TOLERANCES UNLESS OTHERWISE SPECIFIED:		DWN L. ZHANG 17OCT2011		TE Connectivity Harrisburg, PA 17105-3608	
mm	0 PLC ±	1 PLC ±	2 PLC ±	3 PLC ±	4 PLC ±	NAME Ocean Side Feed Applicator	
MATERIAL:		FINISH:		APVD S. XI 17OCT2011		RESTRICTED TO	
				PRODUCT SPEC		SIZE CAGE CODE DRAWING NO	
				APPLICATION SPEC		A1 00779 ©=2151261	
				WEIGHT		SCALE 1:2 SHEET 2 OF 4 REV D	
				Customer Accessible Production Drawing		SHEETS 3 & 4 ARE NOT REQUIRED FOR ATLANTIC VERSION	

PART NUMBER	REVISION	DESCRIPTION	FEED TYPE
2-2151261-1	C	FINE CRIMP HEIGHT ADJUST	MECHANICAL
2-2151261-2	D	FINE CRIMP HEIGHT ADJUST	PNEUMATIC
7-2151261-7	A	CRIMP TOOLING KIT	-

PACIFIC VERSION TERMINATOR  
INTERFACE ADAPTER



APPLICATOR DATA		
CRIMP	SIZE	TYPE
WIRE	2.29 mm [.090]	F
INSUL	3.56 mm [.140]	F

APPLICATOR INSTRUCTIONS  
408-35042

TERMINAL DATA: TE TERMINAL		TE CRIMP SPECIFICATION	
TERMINAL NAME: STANDARD TIMER CONTACT			
WIRE STRIP LENGTH		INSULATION DIAMETER RANGE	
4.30-4.90 mm [.169-.193 IN]		Ø2.00-3.00 mm [.079-.118 IN]	
TERMINAL APPLICATION SPECIFICATION	114-18080	-	-
TERMINALS APPLIED			
TE TERMINAL	TE TERMINAL	TE TERMINAL	TE TERMINAL
925575-1	925575-2	3-925575-1	3-925575-2

TERMINAL DATA: TE TERMINAL		TE CRIMP SPECIFICATION	
TERMINAL NAME: STANDARD TIMER CONTACT			
WIRE STRIP LENGTH		INSULATION DIAMETER RANGE	
4.30-4.90 mm [.169-.193 IN]		Ø2.00-3.00 mm [.079-.118 IN]	
TERMINAL APPLICATION SPECIFICATION	114-18080	-	-
TERMINALS APPLIED			
TE TERMINAL	TE TERMINAL	TE TERMINAL	TE TERMINAL
926965-1	926965-2	3-926965-1	969036-4
3-969036-4			

WIRE SIZE	CRIMP HEIGHT mm [INCH]	CRIMP HEIGHT REFERENCE SETTING
1.50mm2	1.44 +/- 0.05 [.057 +/- .002]	9.7
1.00mm2	1.38 +/- 0.05 [.054 +/- .002]	10.3

WIRE SIZE	CRIMP HEIGHT mm [INCH]	CRIMP HEIGHT REFERENCE SETTING
1.50mm2	1.44 +/- 0.05 [.057 +/- .002]	9.7
1.25mm2	1.41 +/- 0.05 [.056 +/- .002]	10.0
1.00mm2	1.38 +/- 0.05 [.054 +/- .002]	10.3
0.75mm2	1.34 +/- 0.05 [.053 +/- .002]	10.7
0.50mm2	1.30 +/- 0.05 [.051 +/- .002]	11.1



- RECOMMENDED SPARE PARTS
- REFER TO SUPPLIED INSTRUCTION SHEET FOR CLEANING, LUBRICATION AND STORAGE OF APPLICATOR.
- APPLY PART NUMBER 2-23419-6 LOCTITE TO THREADS OF ITEM 242.
- CRIMP HEIGHT REFERENCE SETTING WAS THE SETTING USED WHEN THE APPLICATOR WAS QUALIFIED AT THE FACTORY. ADJUSTMENT MAY BE NECESSARY WHEN RUNNING APPLICATOR IN THE FIELD.
- UNLESS SPECIFIED OTHERWISE TORQUE VALUES SHALL BE USED PER DOCUMENT, 101-35000.

**\*WARNING**  
ON INSTALLATION, SET WIRE DISC TO CRIMP HEIGHT REFERENCE SETTING FOR LARGEST WIRE SIZE. CRIMP HEIGHT REFERENCE SETTINGS GREATER THAN THE VALUE SHOWN MAY CAUSE DAMAGE TO THE CRIMP TOOLING. REFER TO THE INSTRUCTION SHEET FOR PROPER SETUP AND ADJUSTMENTS.

LOC	DIST	REV	DATE	BY	APPV
A	66				

REV	DATE	BY	APPV	DESCRIPTION	ITEM NO
-	-	-	-	SEE SHEET 1	-
-	1	1		2119082-9 CAM, SNAIL, INSULATION ADJUSTMENT	244
-	1	1		2079764-1 WASHER, WAVE SPRING, CREST-TO-CREST	243
-	1	1		2119083-1 RETAINER, INSULATION DIAL	242
-	1	1		18023-1 SCR, SKT HD CAP M3 X 5.0	241
-	-	1		2119580-1 MECHANICAL FEED ASSEMBLY	239
-	1	-		2844940-1 AIR FEED MODULE	238
-	REF	REF		994970-2 COUNTER, MAGNETIC	164
-	1	-		2119641-2 FEED CAM, AIR FEED	151
-	1	1		2168083-8 SCR, SKT HD CAP, RoHS, M4 X 16	144
-	4	4		2168083-9 SCR, SKT HD CAP, RoHS, M4 X 20	143
-	-	1		2119653-2 FEED CAM, POST FEED	142
-	1	1		1-1803583-0 APPLICATOR BASIC ASSEMBLY, SF	141
-	1	1		1803516-1 RAM ASSEMBLY, SF PACIFIC	140
-	1	1		1-18028-2 WASHER, FLAT, REG M4	119
-	1	1		2844908-1 SCREW, LOCKING	99
-	1	1		2844907-1 POST, LOCKING	98
-	1	1		455888-4 SPACER, CRIMPER	82
-	1	1		1803607-3 DOCUMENTATION PACKAGE	71
-	1	1		2119740-1 TAG IDENTIFICATION	67
-	2	2		2168078-1 SCREW, DRIVE, RH, RoHS, 2 x .188	66
-	1	1		5-18022-5 SCR, HEX HD CAP, M4 X 6.0	59
-	1	1		1338685-1 PAWL, FEED	56
-	2	2		2168083-3 SCR, SKT HD CAP, RoHS, M4 X 12.0	53
-	1	1		1803382-6 HOLD DOWN, SPRING LOADED	50
-	1	2		18023-9 SCR, SKT HD CAP M4 X 6.0	49
-	-	1		2119652-1 FEED CAM, PRE FEED	48
-	1	1		1803602-1 SCR, BHSC, RoHS (M8 X 25)	41
-	1	1		1752356-3 SUPPORT, TERMINAL	34
-	2	2		2079383-5 SCR, BHSC, RoHS (M4 X 20)	33
-	2	2		2-2844962-6 SPACER, CYLINDRICAL, STRIP GUIDE	30
-	1	1		2844992-1 ASSEMBLY, STRIP GUIDE	29
-	1	1		1-455888-0 SPACER, CRIMPER	28
-	1	1		1320928-2 STRIP GUIDE	24
-	1	1		2168083-2 SCR, SKT HD CAP, RoHS, M4 X 8.0	21
-	1	1		1-18028-2 WASHER, FLAT, REG M4	20
-	1	1		2119533-1 STRIPPER, SIDE FEED	19
-	1	1		2119806-1 INSERT, SHEAR	13
-	1	1		3-22280-3 SPRING, COMPRESSION	12
-	1	1		1-356885-4 STOP, SHEAR	11
-	1	1		2119805-1 SHEAR HOLDER, FRONT	10
-	1	1		454276-5 FLOATING SHEAR, FRONT	9
-	1	1		1333205-1 ANVIL, COMBINATION	8
-	1	1		1-240641-3 SPACER	7
-	1	1		2119757-4 DEPRESSOR, SHEAR	5
-	1	1		238011-8 BLOCK, CRIMPER SPACER	4
-	1	1		2-2119582-4 CRIMPER, INSULATION F PREMIUM	3
-	1	1		455888-6 SPACER, CRIMPER	2
-	1	1		3-456406-0 CRIMPER, WIRE PREMIUM	1

PACIFIC VERSION  
Shown on sheets 3 of 4 & 4 of 4  
(Atlantic version shown on sheets 1 of 4 & 2 of 4)

DIMENSIONS:		TOLERANCES UNLESS OTHERWISE SPECIFIED:		MATERIAL:		FINISH:	
mm	0 PLC ±	1 PLC ±	2 PLC ±	3 PLC ±	4 PLC ±	ANGLES	

DATE	11OCT2011	CHK	L.ZHANG
DATE	11OCT2011	CHK	L.ZHANG
DATE	11OCT2011	APPV	S.XI
PRODUCT SPEC			
APPLICATION SPEC			
SIZE	CAGE CODE	DRAWING NO	RESTRICTED TO
A1	00779	2151261	
Customer Accessible Production Drawing		SCALE	1:2
SHEET		3	OF 4
REV		D	

LOC		DIST		REVISIONS			
A	66	P	LTM	DESCRIPTION	DATE	OWN	APVD
		-		SEE SHEET 1			

# FEED TYPE MECHANICAL

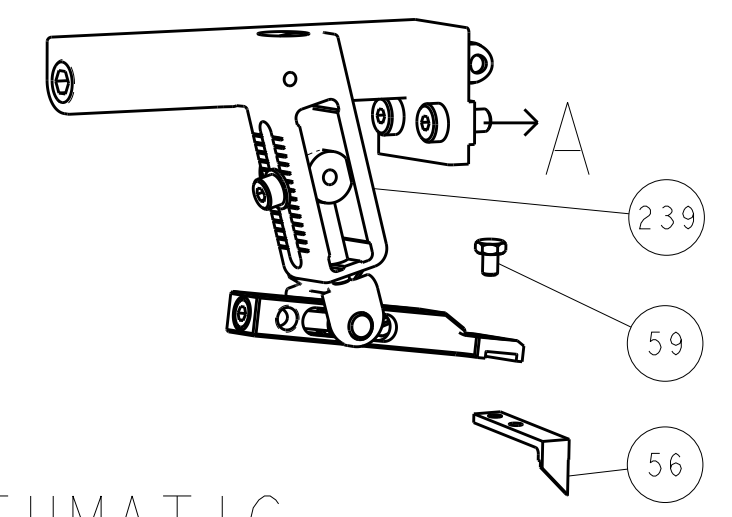

## PNEUMATIC

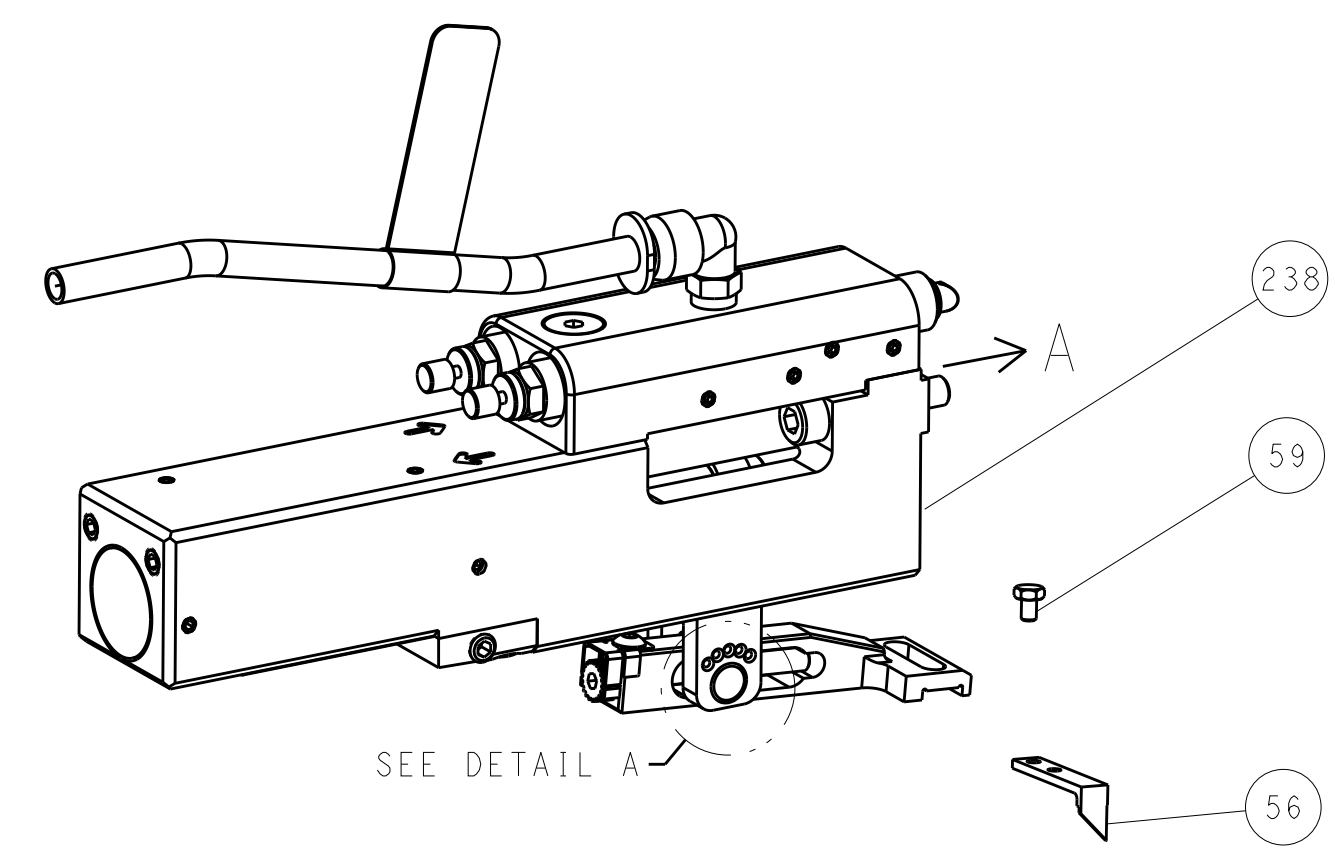

### FEED SPRING SETTING POSITION (SHOWN FROM REAR SIDE)

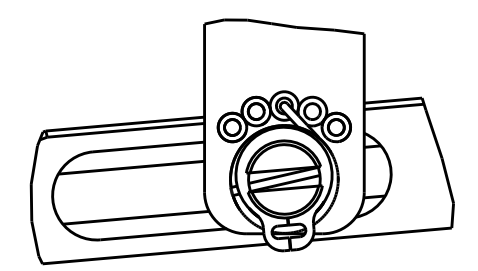

DETAIL A

# CAM POSITIONS

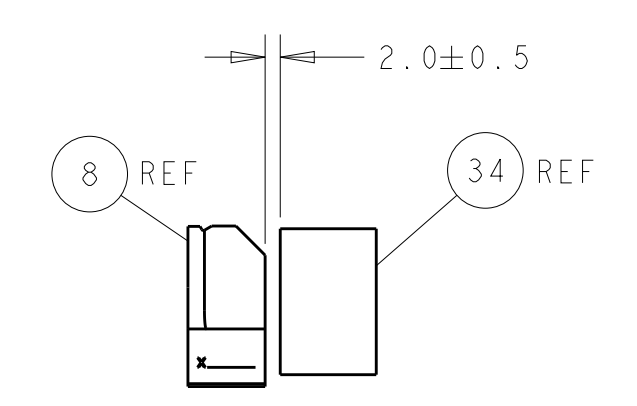
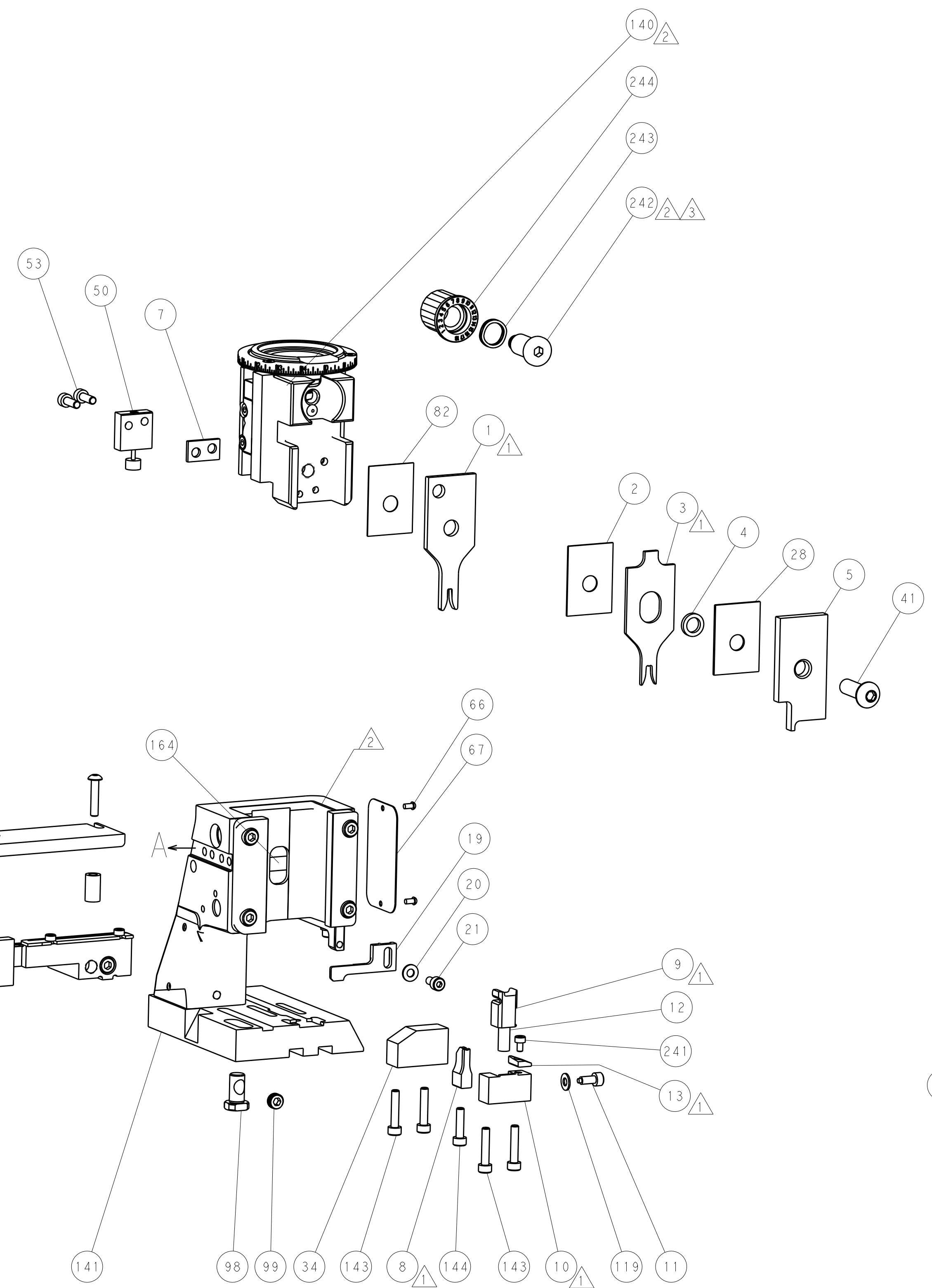
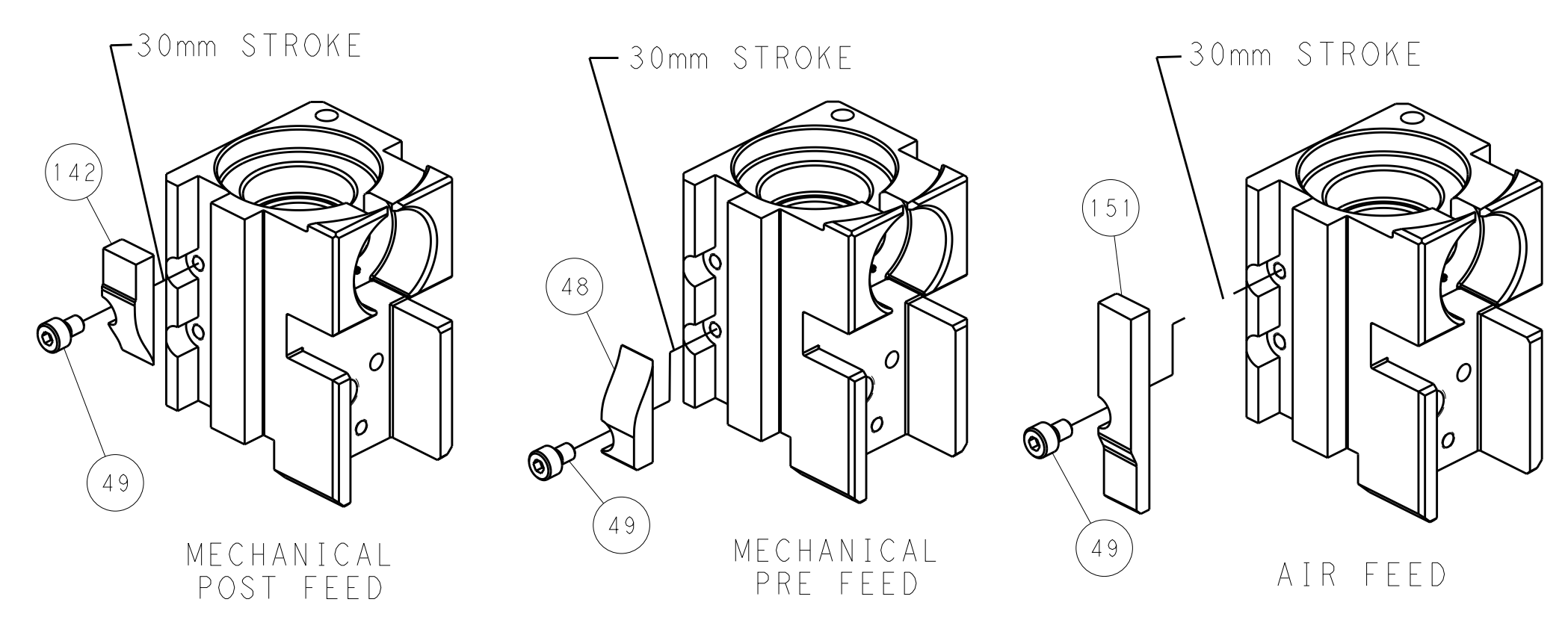

TERMINAL SUPPORT LOCATION

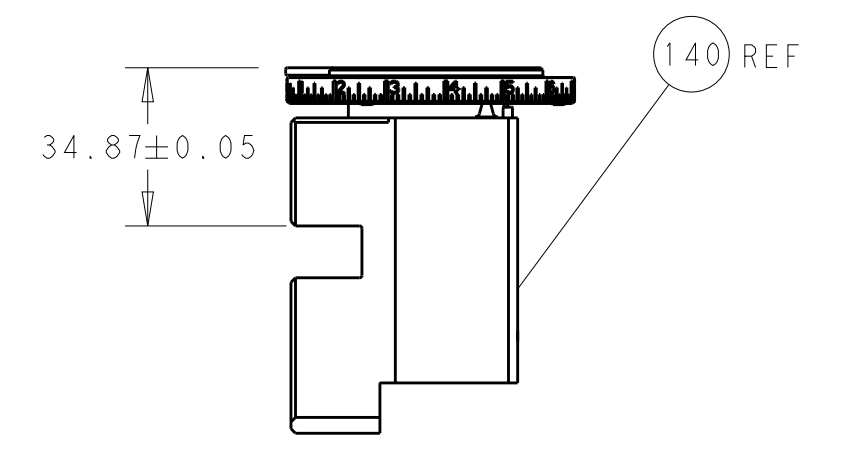

RAM SET-UP

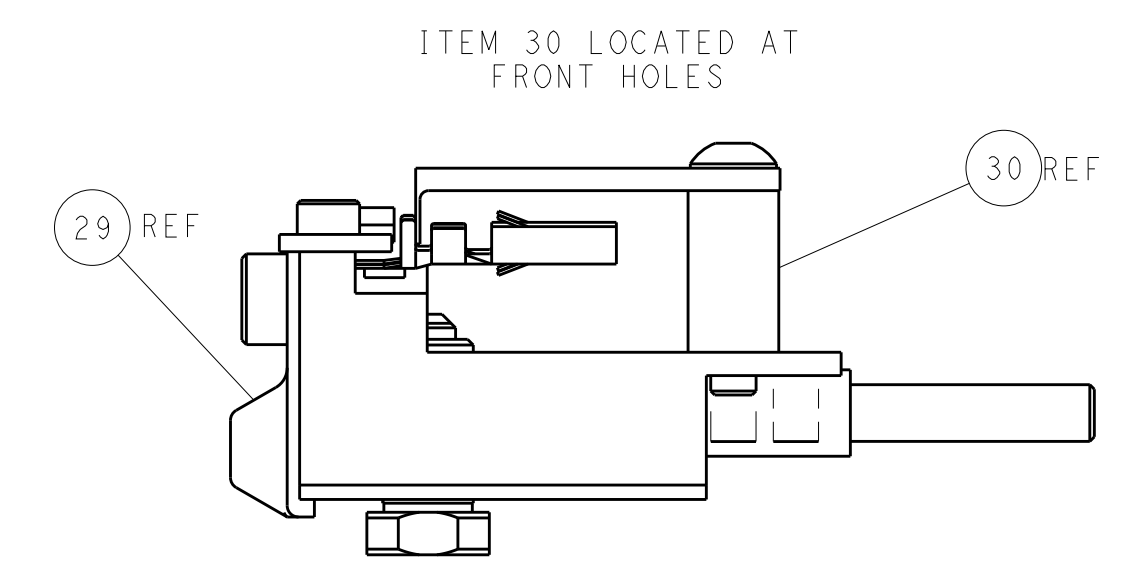

FEED TRACK POSITION  
GUIDE BY INSULATION BARREL

**PACIFIC VERSION**  
 Shown on sheets 3 of 4 & 4 of 4  
 (Atlantic version shown on sheets 1 of 4 & 2 of 4)

DIMENSIONS:		TOLERANCES UNLESS OTHERWISE SPECIFIED:		DWN L. ZHANG 17OCT2011		STE TE Connectivity	
mm	0 PLC ±	1 PLC ±	2 PLC ±	3 PLC ±	4 PLC ±	Harrisburg, PA 17105-3608	
MATERIAL:		FINISH:		S. XI 17OCT2011		NAME	
				PRODUCT SPEC		Ocean Side Feed	
				APPLICATION SPEC		Applicator	
				WEIGHT		SIZE CAGE CODE DRAWING NO	
				Customer Accessible Production Drawing		A1 00779 ©=2151261	
				SCALE		RESTRICTED TO	
				1:2		SHEET 4 OF 4 REV D	