

THIS DRAWING IS UNPUBLISHED. RELEASED FOR PUBLICATION NOV , 2005.
 © COPYRIGHT 2005 By - ALL RIGHTS RESERVED.

LOC	DIST	REVISIONS					
E	B	P	LTR	DESCRIPTION	DATE	DWN	APVD
		C		ECR-13-019838	09MAR2015	RZ	MC

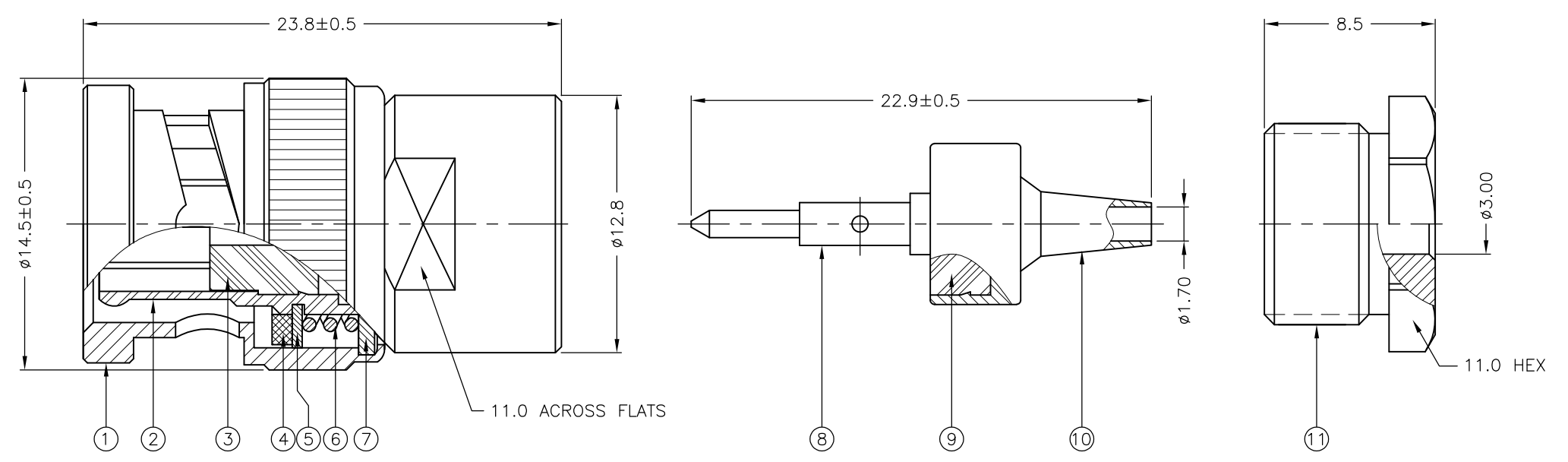

NOTES:

- ① SINGLE PACKING: ONE CONNECTOR PER LABELED BAG PACKAGED. LABELED PER TEC-107-115
- ② TRAY PACKAGED
- ③ Ag PLATING
- ④ PASSIVATED
- ⑤ THIS ITEM MUST BE WHITE

6 ELECTRICAL CHARACTERISTICS

FREQUENCY RANGE:	DC - 2 GHz
NOMINAL IMPEDANCE:	75 Ohm
INSULATION RESISTANCE:	5000 MOhm
WORKING VOLTAGE:	500 Volts RMS at Sea Level
DIELECTRIC WITHSTAND VOLTAGE:	1500 Volts RMS Max
CONTACT RESISTANCE:	
CENTER CONTACT:	1.50 mOhm Max
OUTER CONTACT:	1.00 mOhm Max
VSWR @ 2GHz:	1.30:1 Max
INSERTION LOSS dB @ x 1 GHz:	0.20 Max

9 MECHANICAL CHARACTERISTICS

COUPLING NUT RETENTION FORCE:	266N Min
CABLE RETENTION FORCE:	54.4 N Min
DURABILITY:	500 Cycles Min

10 ENVIRONMENTAL CHARACTERISTICS

OPERATING TEMPERATURE:	-65 to +165 DegC
------------------------	------------------

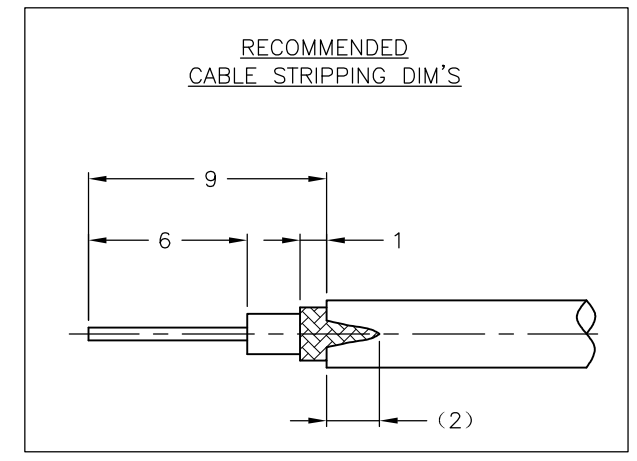

QTY	QTY PER ASSY	MATERIAL	DESCRIPTION	ITEM
1	1	BRASS	CLAMP NUT	11
1	1	BRASS	SLEEVE	10
1	1	PTFE	INSULATION	9
1	1	BRASS	CONTACT	8
1	1	BRASS	WASHER	7
1	1	STAINLESS STEEL	SPRING	6
2	2	BRASS	CIRCLIP	5
1	1	SILICON RUBBER	GASKET	4
1	1	PTFE	INSULATION	3
1	1	BRASS	BODY	2
1	1	BRASS	COUPLING NUT	1
6--0	1--0	MATERIAL	DESCRIPTION	ITEM

THIS DRAWING IS A CONTROLLED DOCUMENT.		DWN	A.BEKEN	21-11-01	STE TE Connectivity											
DIMENSIONS: mm		CHK	R.G	21-11-01												
TOLERANCES UNLESS OTHERWISE SPECIFIED:		APVD	F.W-KING	21-11-01												
<table border="0"> <tr><td>0 PLC</td><td>± 0.5</td></tr> <tr><td>1 PLC</td><td>± 0.2</td></tr> <tr><td>2 PLC</td><td>± 0.1</td></tr> <tr><td>3 PLC</td><td>± -</td></tr> <tr><td>4 PLC</td><td>± -</td></tr> <tr><td>ANGLES</td><td>± -</td></tr> </table>		0 PLC	± 0.5	1 PLC		± 0.2	2 PLC	± 0.1	3 PLC	± -	4 PLC	± -	ANGLES	± -	PRODUCT SPEC	
0 PLC	± 0.5															
1 PLC	± 0.2															
2 PLC	± 0.1															
3 PLC	± -															
4 PLC	± -															
ANGLES	± -															
MATERIAL: SEE TABLE		FINISH: -		108-112000	BNC STRAIGHT PLUG SOLDER (PS) 75 OHM RG179B/U, 187A/U, URM111											
		APPLICATION SPEC	-		RESTRICTED TO											
		WEIGHT	-		SIZE											
		CUSTOMER DRAWING		SCALE	CAGE CODE											
				NTS	A300779											
				SHEET	DRAWING NO											
				1 OF 2	C-1478403											
				REV	C											

THIS DRAWING IS UNPUBLISHED.

RELEASED FOR PUBLICATION NOV , 2005.

© COPYRIGHT 2005 By -

ALL RIGHTS RESERVED.

LOC E DIST B

REVISIONS

P	LTR	DESCRIPTION	DATE	DWN	APVD
-	-	SEE SHEET 1	-	-	-

COMPONENTS

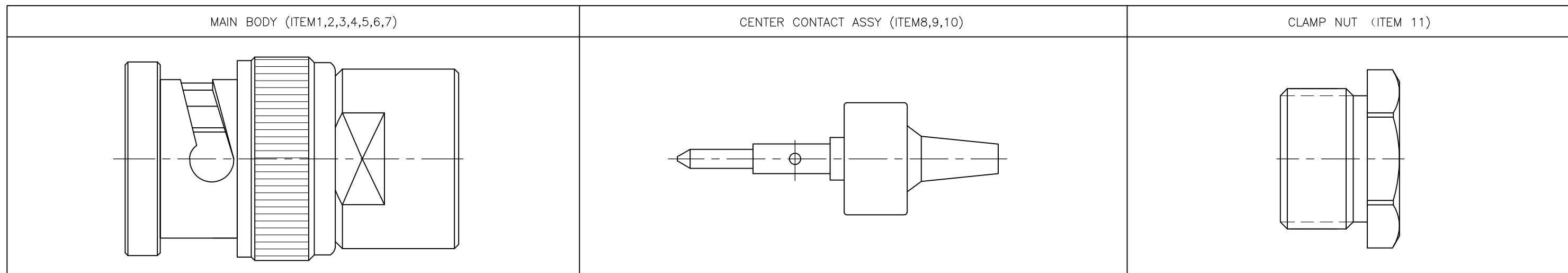

ASSEMBLY INSTRUCTIONS

STEP 1: PREPARATION OF CABLE

1. TRIM CABLE TO DIMENSIONS SHOWN. BE CAREFUL TO AVOID NICKING THE BRAID.
2. REMOVE ANY RESIDUAL PLASTIC FROM CENTER CONDUCTOR.
3. CUT A RIP ON THE CABLE JACKET AS DIMENSION SHOWN.

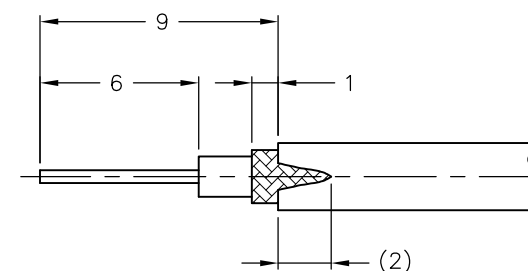

STEP 2: ASSEMBLE CLAMP NUT, WASHER, GASKET, WAhSER, SLEEVE, DIELECTRIC AND CENTER CONTACT

1. SLIDE CLAMP NUT ON THE CABLE.
2. INSERT CABLE INTO CENTER CONTACT ASSEMBLY. AND FLARE THE BRAID WIRES AND OVER ON SLEEVE.
3. SOLDERING CENTER CONTACT WITH CABLE.

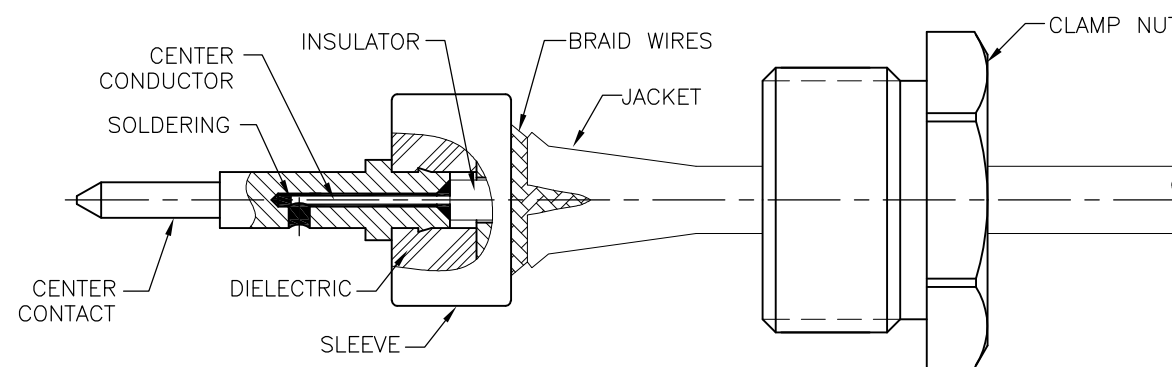

STEP 3: SCREW NUT TO CONNECTOR

1. INSERT STEP 2 CABLE ASSEMBLY INTO CONNECTOR BODY AND SCREW TIGHT THE CLAMP NUT.

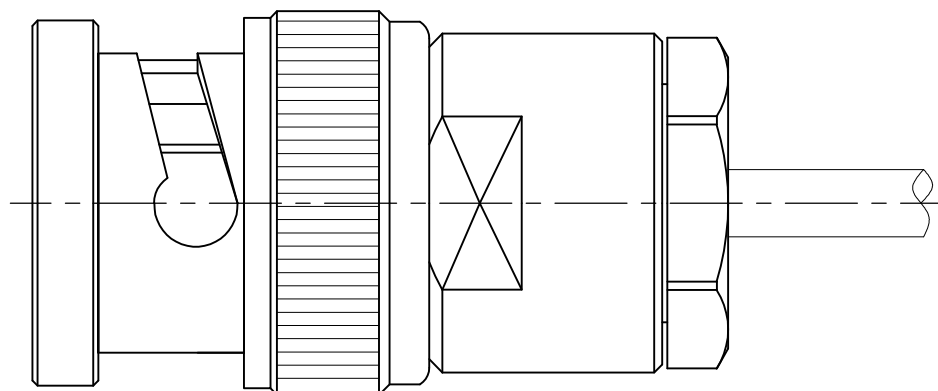

THIS DRAWING IS A CONTROLLED DOCUMENT.		DWN A.BEKEN 21-11-01	STE TE Connectivity		
DIMENSIONS: mm		CHK R.G 21-11-01			
TOLERANCES UNLESS OTHERWISE SPECIFIED:		APVD F W-KING 21-11-01	NAME BNC STRAIGHT PLUG SOLDER (PS) 75 OHM RG179B/U, 187A/U, URM111		
0 PLC ± -		PRODUCT SPEC SEE SHEET1	-		
1 PLC ± -		APPLICATION SPEC -	SIZE A3	CAGE CODE 00779	DRAWING NO C-1478403
2 PLC ± -		WEIGHT -	RESTRICTED TO -		
3 PLC ± -		MATERIAL SEE TABLE	SCALE NTS		
4 PLC ± -			SHEET 2 OF 2		
ANGLES ± -		CUSTOMER DRAWING			REV C
FINISH -					