

## MOTOR SPECIFICATIONS

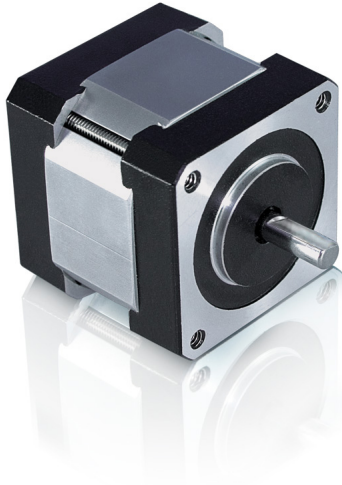

## DIMENSIONS

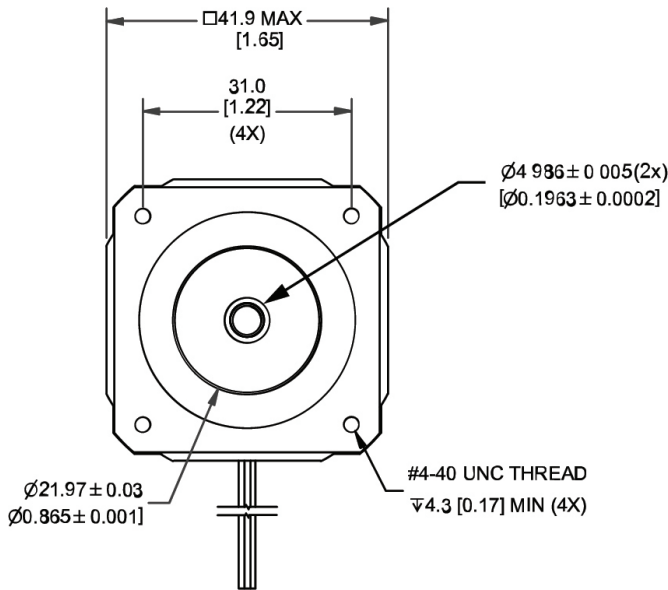

Part Number	<b>WO-417-11-03</b>
Step Angle	0.9°
Frame Size	NEMA 17
Body Length (Dim. A)	1.1 in (27.9 mm)
Current	1.2 Amps/Phase
Holding Torque	16 oz-in (0.11 Nm)
Resistance	3 Ohms/Phase
Rotor Inertia	0.07 oz-in <sup>2</sup>
Number of Leads	4
Connection	Bipolar
Weight	0.31 lbs (0.14 kg)

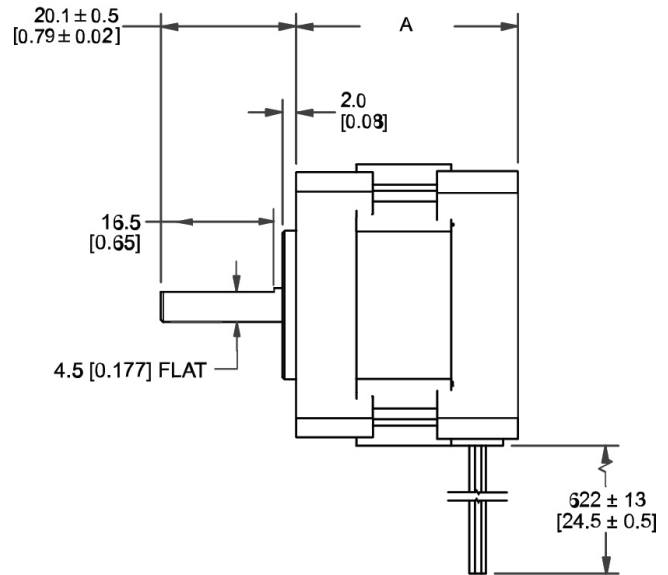

## PERFORMANCE CURVE

**417-11-03**  
 24 VCD, 1.2 AMP

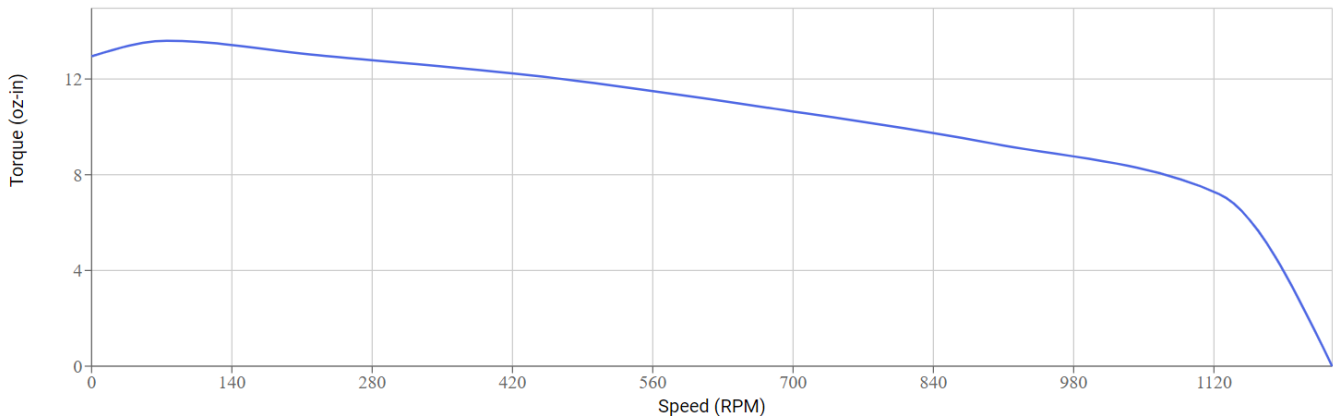

## OPERATING SPECIFICATIONS

Radial Play	0.001" max @ 1 lbs load
End Play	0.003" max @ 2 lbs load
Shaft Run Out	0.002" TIR
Concentricity of Mounting Pilot to Shaft	0.003" TIR
Perpendicularity of Shaft to Mounting Face	0.003" TIR
Max Axial Load	6 lbs
Maximum Case Temperature	80 C
Ambient Temperature	-20° to 50° C
Storage Temperature	-20° to 100° C
Humidity Range	85% or less, non-condensing
Magnet Wire Insulation	Class B 130° C
Insulation Resistance	100MΩ at 500 VDC
Dielectric Strength	500 VAC for 1 minute

## WIRING TABLE

COLOR	FUNCTION
Red	A+ Phase
Blue	A- Phase
Green	B + Phase
Black	B- Phase

## OPERATION & USAGE TIPS



**Do not** disassemble motors; a significant reduction in motor performance will occur.



**Do not** machine shafts; this will have a negative effect on shaft run out and perpendicularity.



**Do not** disconnect motor from drive while in operation.



**Do not** use holding torque/detent torque of motor as a fail safe brake.



**Do not** hold motor by lead wires.



**Do not** exceed the rated current; this will burn the motor.

FAILURE TO COMPLY WITH THESE RECOMMENDATIONS WILL VOID ALL WARRANTY TERMS

## RECOMMENDED



Microstepping Driver  
**R208**



Single Axis Controller  
+ Driver  
**R256-RO**

# Motion Control, **Solved.**

## MOTOR ENGINEERING & MANUFACTURING



Optimized  
For Your  
Application



Quick  
Prototype  
Turnaround



Small Batch  
to OEM Volume  
Production



US Based  
Support &  
Manufacturing