

# OPERATION MANUAL

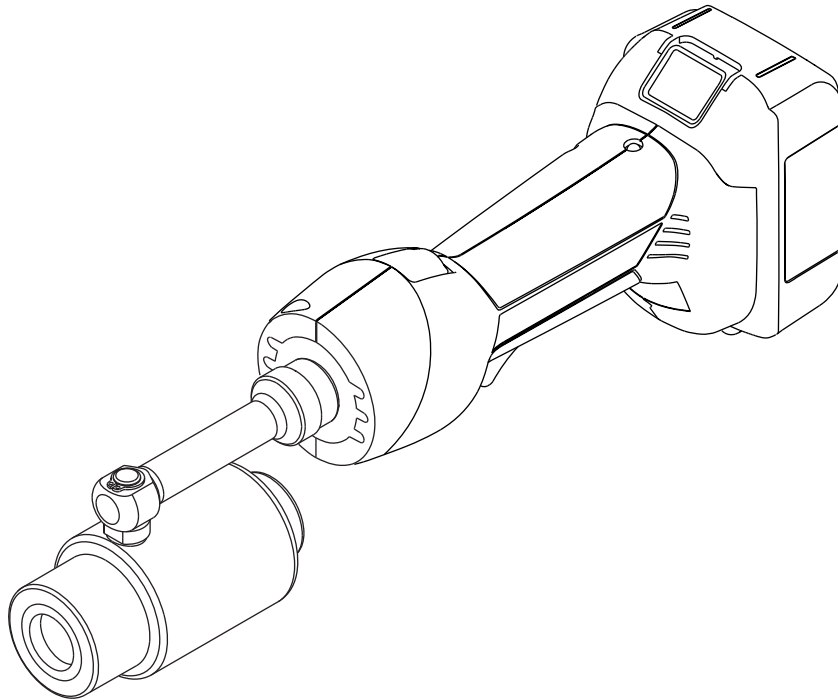

Serial Number



## **GATOR® LS50L** **Battery-powered Punch Driver**



**Read and understand** all of the instructions and safety information in this manual before operating or servicing this tool.

Register this product at [www.greenlee.com](http://www.greenlee.com)

## Table of Contents

Description .....	2
Safety .....	2
Purpose of this Manual .....	2
Important Safety Information .....	3–5
Identification .....	6
Specifications .....	6
Setup and Operation .....	7–12
Capacity and Draw Stud Selection Guide.....	13
Maintenance.....	14
Troubleshooting.....	15

## Description

The Greenlee LS50L Battery-powered Punch Driver is a hand-held, self-contained punch driver intended to be used with Greenlee punches, dies, and draw studs for punching holes through plastic, fiberglass, aluminum, and steel.

The LS50L is designed to be used with the following Greenlee accessories:

- Standard punches, dies, and draw studs
- Slug-Buster® punches, dies, and draw studs
- Slug-Splitter® punches, dies, and draw studs
- Electronic connector panel punches
- Special shape punches, dies, and draw studs (“D”, Double “D”, Key, Square, Rectangular, and Oiltight with notches)

Standard, Slug-Buster, Electronic Connector Panel Punches, and special shape punches can punch holes through plastic, fiberglass, aluminum, and steel. Slug-Splitter punches, dies, and draw studs are capable of punching through all of these materials as well as stainless steel. Refer to the “Capacity and Draw Stud Selection Guide” in this manual for detailed information on punch sizes and maximum material thickness. Do not exceed the capacity of the punch.

This tool is protected by U.S. Patent No. 6,276,186, 6,401,515, 7,086,979, and 7,254,982.

## Safety

Safety is essential in the use and maintenance of Greenlee tools and equipment. This manual and any markings on the tool provide information for avoiding hazards and unsafe practices related to the use of this tool. Observe all of the safety information provided.

## Purpose of this Manual

This manual is intended to familiarize all personnel with the safe operation and maintenance procedures for the following Greenlee tool:

LS50L Battery-powered Punch Driver

Keep this manual available to all personnel.

Replacement manuals are available upon request at no charge at [www.greenlee.com](http://www.greenlee.com).

All specifications are nominal and may change as design improvements occur. Greenlee Textron Inc. shall not be liable for damages resulting from misapplication or misuse of its products.

GATOR, Kwik-Stepper, Slug-Buster, and Slug-Splitter are registered trademarks of Textron Innovations Inc.



**Do not discard this product or throw away!**

For recycling information, go to [www.greenlee.com](http://www.greenlee.com).

# KEEP THIS MANUAL

## IMPORTANT SAFETY INFORMATION



### SAFETY ALERT SYMBOL

This symbol is used to call your attention to hazards or unsafe practices which could result in an injury or property damage. The signal word, defined below, indicates the severity of the hazard. The message after the signal word provides information for preventing or avoiding the hazard.

#### ⚠ **DANGER**

Immediate hazards which, if not avoided, **WILL** result in severe injury or death.

#### ⚠ **WARNING**

Hazards which, if not avoided, **COULD** result in severe injury or death.

#### ⚠ **CAUTION**

Hazards or unsafe practices which, if not avoided, **MAY** result in injury or property damage.

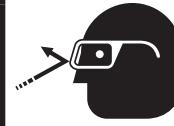

#### ⚠ **WARNING**

Wear eye protection when operating or servicing this tool.

Failure to wear eye protection could result in serious eye injury from flying debris or hydraulic oil.



#### ⚠ **WARNING**

Skin injection hazard:

Do not use hands to check for oil leaks. Oil under pressure easily punctures skin. If injured, seek medical attention immediately to remove oil.

Failure to observe this warning could result in serious injury, gangrene, or death.



#### ⚠ **WARNING**

Do not use solvents or flammable liquids to clean the tool body. Solvents or flammable liquids could ignite and cause serious injury or property damage.



#### ⚠ **WARNING**

Read and understand all of the instructions and safety information in this manual before operating or servicing this tool.

Failure to observe this warning could result in severe injury or death.



#### ⚠ **WARNING**

Electric shock hazard:

This tool is not insulated. When using this unit on or near energized electrical lines, use proper personal protective equipment.

Failure to observe this warning could result in severe injury or death.



#### ⚠ **WARNING**

Pinch points:

- Remove battery before changing dies, adapters, or jaws.
- Keep hands away from the tool head when punching.

Failure to observe these warnings could result in severe injury or death.

## IMPORTANT SAFETY INFORMATION

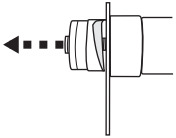
	<p style="text-align: center;"><b>⚠ WARNING</b></p> <p>A component failure could throw broken parts.</p> <ul style="list-style-type: none"> <li>• Do not allow anyone to stand in front of the punch or behind the hydraulic ram.</li> <li>• Close access doors or covers on any equipment that is in line with the punch or ram.</li> </ul> <p>Failure to observe this warning could result in severe injury or death.</p>
---	---

<p style="text-align: center;"><b>⚠ WARNING</b></p> <ul style="list-style-type: none"> <li>• Inspect tool for wear or damage. Replace any worn, damaged, or missing components with Greenlee replacement parts. A damaged or improperly assembled tool can break and strike nearby personnel with sufficient force to cause severe injury or death.</li> <li>• Inspect the punch, die, draw stud, and spacers for wear or damage. Replace any worn or damaged items with Greenlee replacement parts. Replace any punches that have dull cutting surfaces.</li> </ul>
--

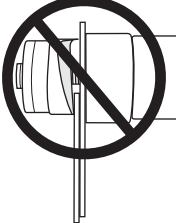
	<p style="text-align: center;"><b>⚠ WARNING</b></p> <p>Do not attempt to punch a hole through two or more layers of material. This will bend or break the draw stud, and could throw parts with great force.</p> <p>Failure to observe this warning could result in severe injury or death.</p>
--	---

<p style="text-align: center;"><b>⚠ WARNING</b></p> <p>Do not exceed the rated capacity of this tool. Exceeding the rated capacity could cause a component failure, which could throw broken parts with great force.</p> <p>Failure to observe this warning could result in severe injury or death.</p>
---

<p style="text-align: center;"><b>⚠ WARNING</b></p> <p>Set up the tool properly. An improper setup could cause a component to fail and strike nearby personnel with great force.</p> <ul style="list-style-type: none"> <li>• Thread the punch completely onto the draw stud. All of the punch threads must be engaged by the draw stud threads. Incomplete assembly could cause a component failure.</li> <li>• Use only Greenlee punches, dies, and draw studs. Other manufacturers' components might not withstand the forces generated by this punch driver.</li> </ul> <p>Failure to observe these warnings could result in severe injury or death.</p>
--

<p style="text-align: center;"><b>⚠ WARNING</b></p> <p>Do not dispose of batteries in a fire. They will vent fumes and may explode.</p> <p>Failure to observe this warning could result in severe injury from harmful fumes or burns from flying debris.</p>
--

## **IMPORTANT SAFETY INFORMATION**

### **⚠ CAUTION**

- Do not use this tool for continuous use. After 30 to 40 cycles, allow the tool to cool for 15 minutes.
- Do not secure this tool in a vise. This tool is designed for hand-held operation.
- This tool may be used in damp or wet environments; however, air-drying is recommended before use if the tool becomes soaked. Damage may result when the tool is operated prior to thorough drying when electrical components are soaked.
- Use this tool for the manufacturer's intended purpose only.

Failure to observe these precautions may result in injury or property damage.

### **⚠ CAUTION**

Do not allow anything to contact the battery terminals.

- Do not immerse the batteries in liquid. Liquid may create a short circuit and damage the battery. If batteries are immersed, contact your service center for proper handling.
- Do not place the battery into a pocket, tool pouch, or tool box with conductive objects. Conductive objects may create a short circuit and damage the battery.
- Do not place a battery on moist ground or grass. Moisture may create a short circuit and damage the battery.

Failure to observe these precautions may result in injury or property damage.

### **⚠ CAUTION**

- Do not store the battery at more than 122 °F (50 °C) or less than -4 °F (-20 °C). Damage to the battery can result.
- Do not use another manufacturer's charger. Other manufacturers' chargers may overcharge and damage the battery.
- Do not attempt to open the battery. It contains no user-serviceable parts.

Failure to observe these precautions may result in injury or property damage.

### **⚠ CAUTION**

Do not perform any service or maintenance other than as described in this manual. Injury or damage to the tool may result.

Failure to observe this precaution may result in injury and property damage.

*Note: Keep all decals clean and legible, and replace when necessary.*

**Identification**

- 1. Punching Head
- 2. Return Button
- 3. LED Indicator (red)
- 4. Battery Lock
- 5. Battery Cartridge
- 6. LED Work Light (white)
- 7. Trigger

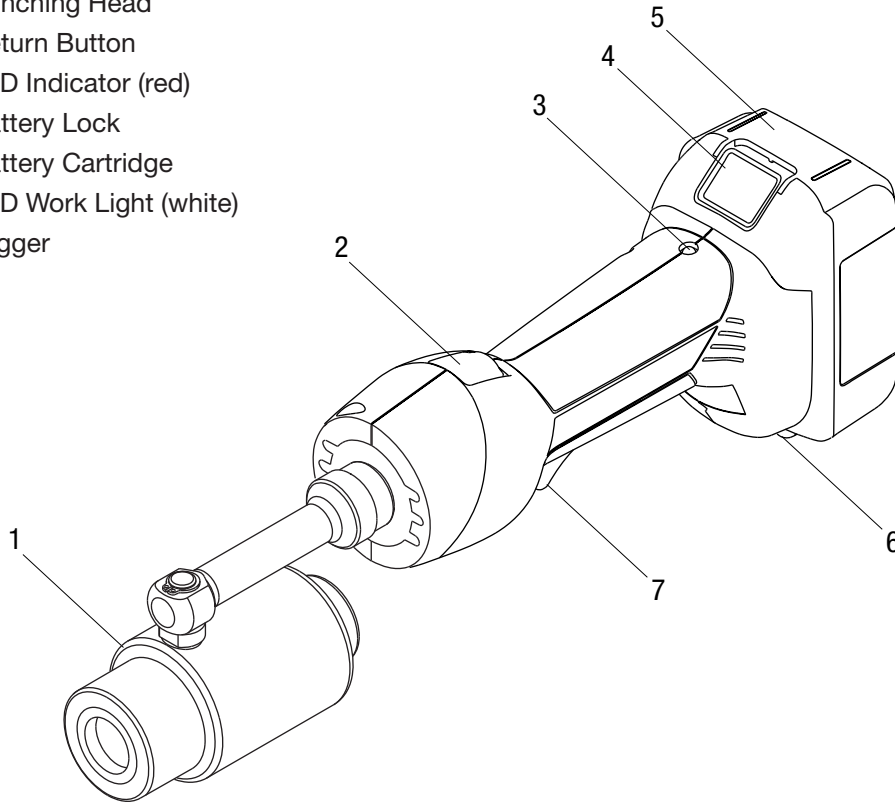

**Specifications**

**Punch Driver**

Length.....	14.25" (362 mm)
Width .....	2.87" (72.9 mm)
Depth.....	4.50" (114.3 mm)
Weight.....	4.6 lb (2 kg)
Force.....	6.7 tons (60 kN)
Hydraulic Oil .....	52057878 biodegradable hydraulic fluid
Recommended Operating Temperature Range.....	5 °F to 122 °F (-15 °C to 50°C)
Battery Charger.....	Read the instructions supplied with the battery charger

52047087	120 VAC corded adapter	52054992	Li (18 V) to NiCd, NiMH (12 V) charger adapter
52047088	230 VAC corded adapter	52049201	120 VAC, 18 V charger
52049190	18 V, 1.5 Ah lithium-ion battery	52049202	230 VAC, 18 V charger
52049189	18 V, 3.0 Ah lithium-ion battery	52049204	12 VDC, 18 V charger

## Setup and Operation

### ⚠ WARNING

- Inspect tool for wear or damage. Replace any worn, damaged, or missing components with Greenlee replacement parts. A damaged or improperly assembled tool can break and strike nearby personnel with sufficient force to cause severe injury or death.
- Inspect the punch, die, draw stud and spacers for wear or damage. Replace any worn or damaged items with Greenlee replacement parts. Replace any punches that have dull cutting surfaces.

### ⚠ CAUTION

- Do not use this tool for continuous use. After 30 to 40 cycles, allow the tool to cool for 15 minutes.
- Do not secure this tool in a vise. This tool is designed for hand-held operation.
- This tool may be used in damp or wet environments; however, air-drying is recommended before use if the tool becomes soaked. Damage may result when the tool is operated prior to thorough drying when electrical components are soaked.
- Use this tool for the manufacturer's intended purpose only.

Failure to observe these precautions may result in injury or property damage.



### ⚠ WARNING

Electric shock hazard:

This tool is not insulated. When using this unit on or near energized electrical lines, use proper personal protective equipment.

Failure to observe this warning could result in severe injury or death.

### Charging the Battery

Read the instructions supplied with the battery charger.

### LED Work Light (white)

This LED automatically turns on when the trigger is pulled. It remains on for 10 seconds after the trigger is released.

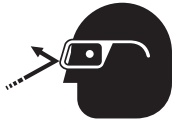

### ⚠ WARNING

Wear eye protection when operating or servicing this tool.

Failure to wear eye protection could result in serious eye injury from flying debris or hydraulic oil.

### LED Indicator (red)

This tool is equipped with a special circuit board incorporating several important features to inform the user about the current status of the unit. The LED signals in the following cases:

What happens	Signal	What it means
Flashing light for 2 seconds	● ●	Battery is inserted in tool
Constant light for 20 seconds at end of cycle	■	Battery charge is below 17 V at beginning of cycle
Tool will <b>not</b> start, and constant light for 20 seconds when trigger is released	■	Battery charge is below 16 V at beginning of cycle
Tool will stop, and constant light for 20 seconds after trigger is released	■	Battery voltage drops below 13 V during cycle
Tool will stop, and flashing light for 20 seconds when trigger is released	● ● ● ●	Motor current exceeds 20 A during cycle Circuit has become too hot



### ⚠ WARNING

Pinch points:

- Remove battery before changing dies, adapters, or jaws.
- Keep hands away from the tool head when punching.

Failure to observe these warnings could result in severe injury or death.

## Setup and Operation (cont'd)

### Punching

*Note: The LS50L is equipped with a microprocessor to control the operation. It automatically shuts off if punching does not begin within 1 second after pulling the trigger. This guarantees the entire stroke is available for punching and saves power.*

1. Select the punch, die, and draw stud that will make the appropriate size hole. Refer to illustrations on the following pages.
2. Determine and mark the exact location for the hole. Use a Greenlee Kwik-Stepper® drill bit to drill a hole that is slightly larger than the draw stud. This is the pilot hole.
3. Push the return button and the ram will return fully.
4. Thread the 3/4" draw stud completely into the punch driver. Refer to illustrations on the following pages.
5. Install a spacer, if necessary. Refer to illustrations on the following pages.
6. Slide the die over the draw stud with the open end of the die facing away from the punch driver.
7. Insert the draw stud through the pilot hole.
8. Thread the punch onto the draw stud with the cutting surfaces of the punch facing the material. Tighten the punch by hand until the spacer, die, material, and punch contact each other.  
*Note: The 3-1/2" to 6" punches require the threaded sleeve prior to assembly to the draw stud.*  
*Note: All of the punch threads must be engaged by the draw stud threads. If any of the punch threads are not engaged, disassemble the setup, remove the spacer, and reassemble the setup.*
9. Pull the trigger. The LS50L will automatically shut off when it senses that the punch is completely through the material.

### IMPORTANT

Release the trigger when the punch completes the hole. The LS50L may not sense when a hole is made in sheets thinner than 18 ga. (1 mm) and soft materials (such as plastic, etc.).

*Note: A "popping" sound indicates that the LS50L has reached relief pressure. This may indicate that the operation attempted is beyond the capacity of the tool.*

10. Release the trigger. When the punch is completed, the ram will return completely.  
*Note: At any time during the punching cycle, pushing the return button will result in a complete return of the ram.*
11. Unscrew the punch. Remove slugs from the die. Remove the spacer and unscrew the draw stud.



**Setup and Operation (cont'd)**

*Note: Refer to "Capacity and Draw Stud Selection Guide" on page 13 for capacity, draw stud, and hardware.*

**Punching mild steel with  
1/2" (ø 0.885" [22.5 mm])  
conduit size**

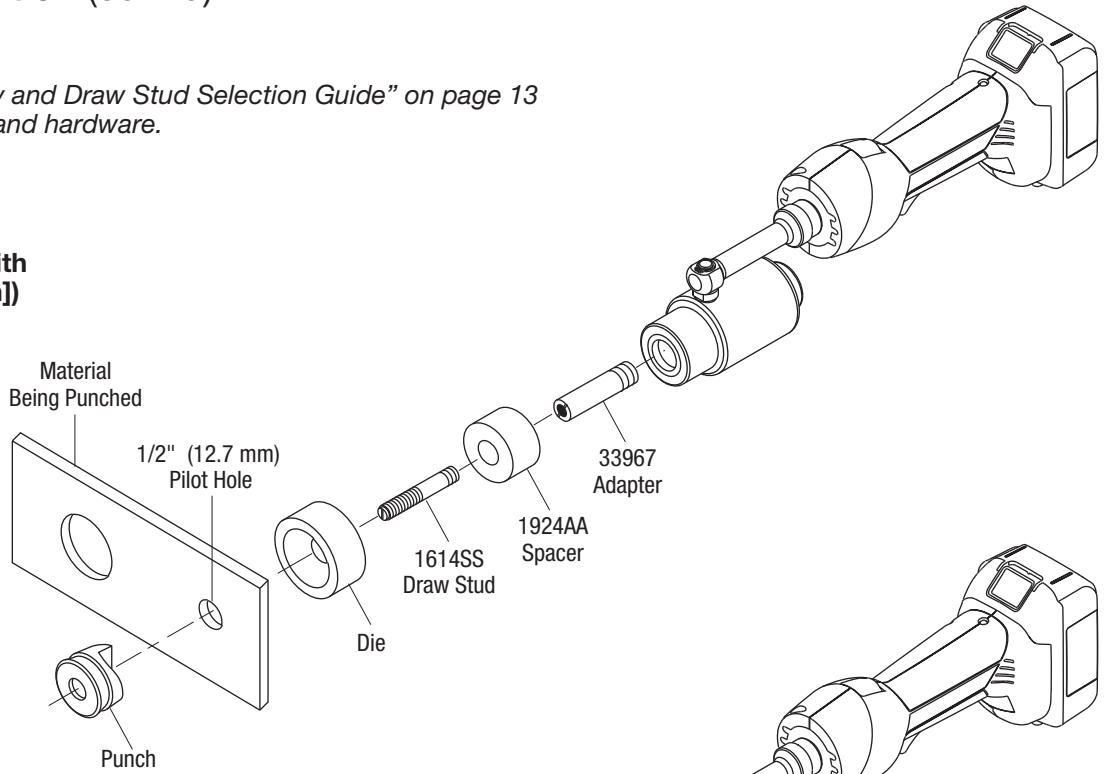

**Punching mild steel with  
3/4" (ø 1.115" [28.3 mm])  
to 1-1/4" (ø 1.701" [43.2 mm])  
conduit sizes**

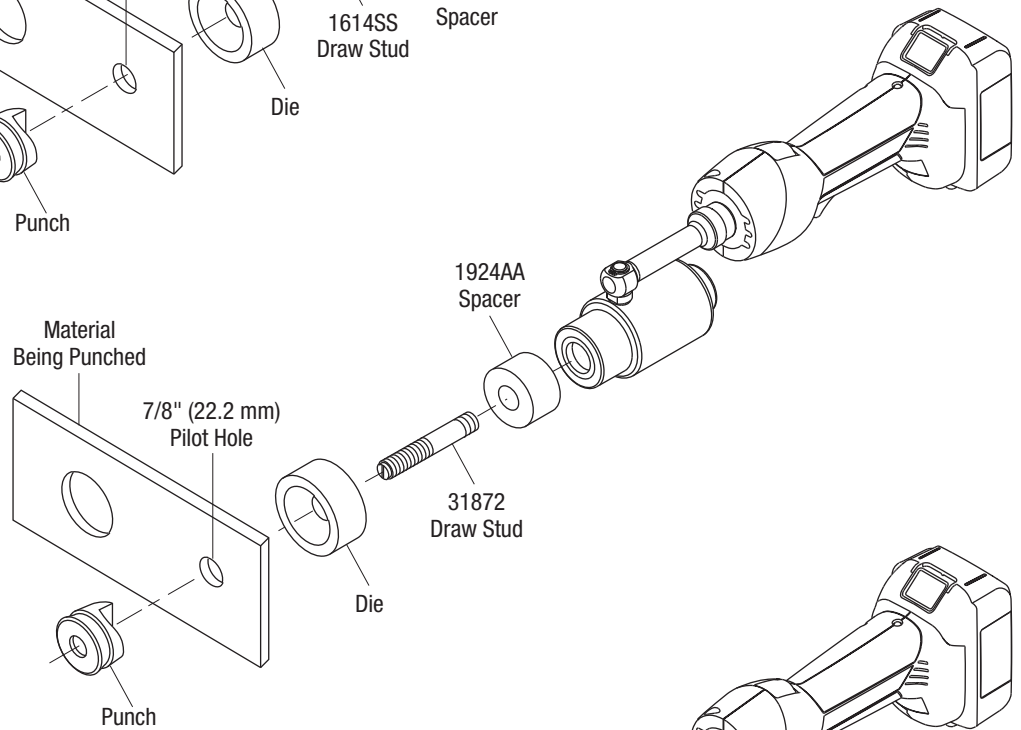

**Punching mild steel with  
1-1/2" (ø 1.951" [49.6 mm])  
to 3" (ø 3.539" [89.9 mm])  
conduit sizes**

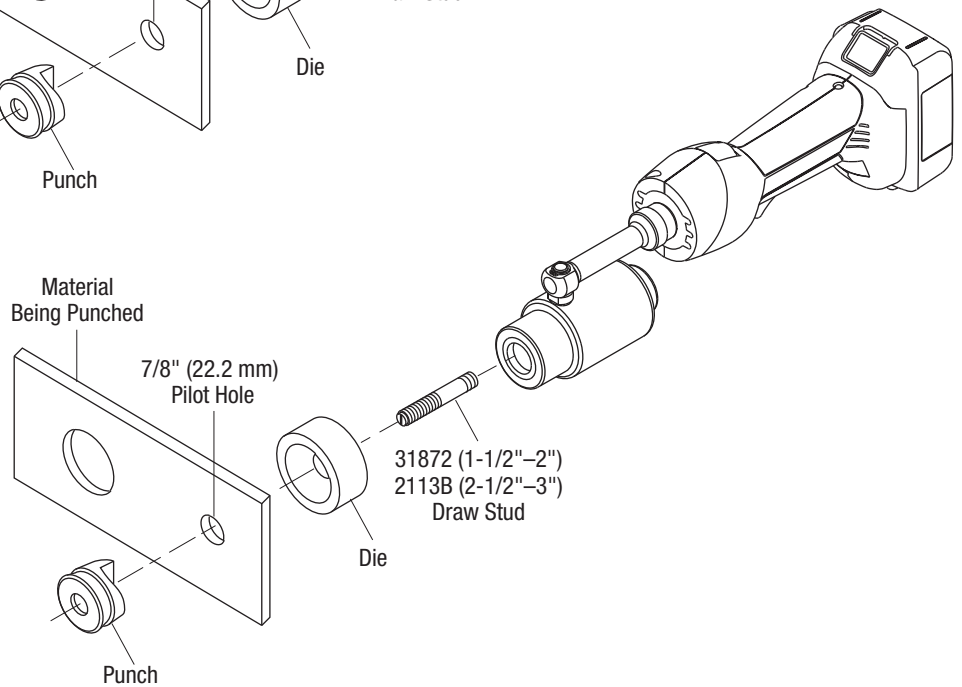

**Setup and Operation (cont'd)**

*Note: Refer to "Capacity and Draw Stud Selection Guide" on page 13 for capacity, draw stud, and hardware.*

**Punching mild steel with 3-1/2" (ø 4.044" [102.7 mm]) to 6" (ø 6.375" [161.9 mm]) conduit sizes**

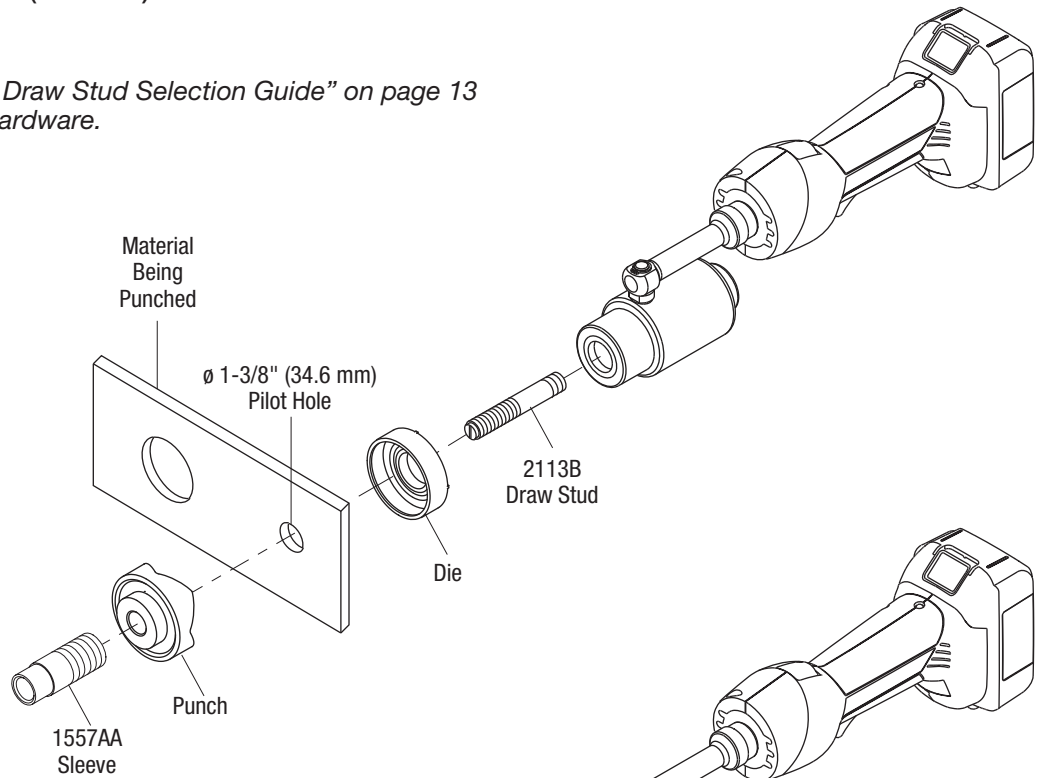

**Punching stainless steel with 1/2" (ø 0.885" [22.5 mm]) conduit size**

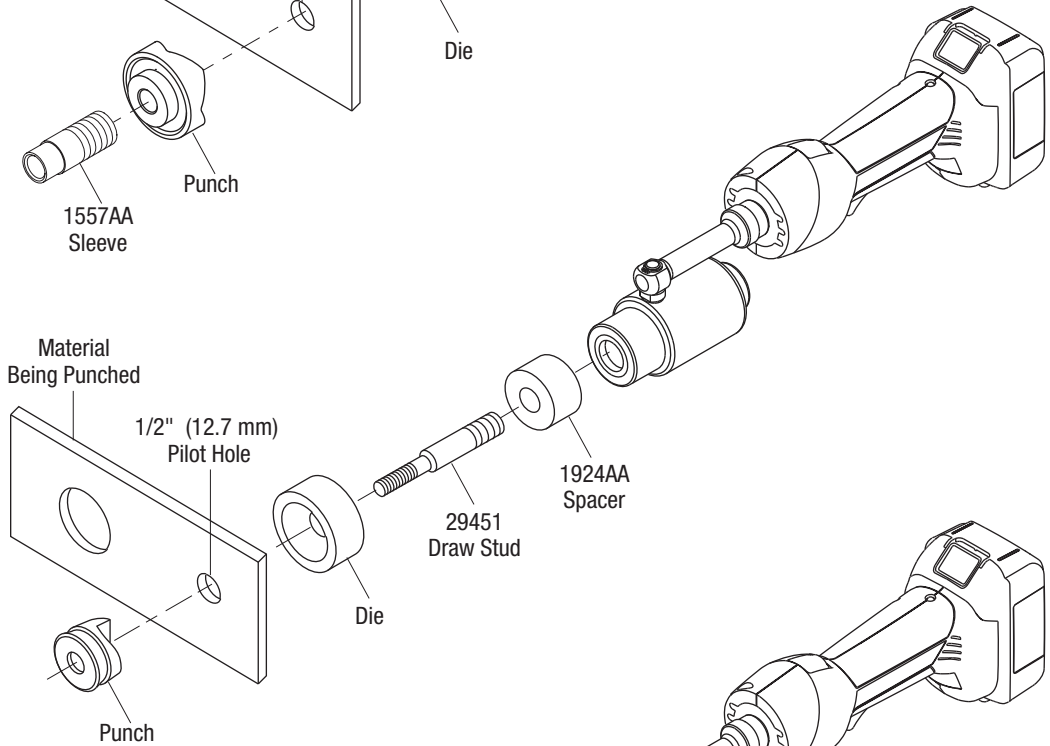

**Punching stainless steel with 3/4" (ø 1.115" [28.3 mm]) to 2" (ø 2.416" [61.5 mm]) conduit sizes**

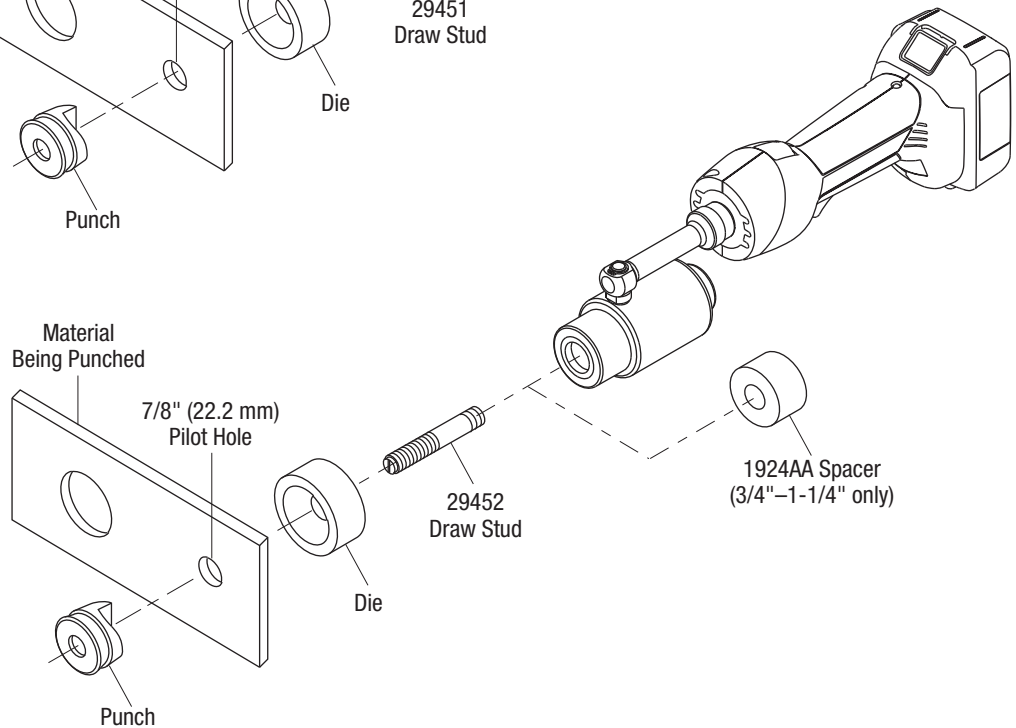

**Setup and Operation (cont'd)**

**Punching with  
 1/2" (0.500" [12.7 mm]) square  
 7/16" x 7/8" (0.437" x 0.875" [11.1 mm x 22.2 mm]) rectangular**

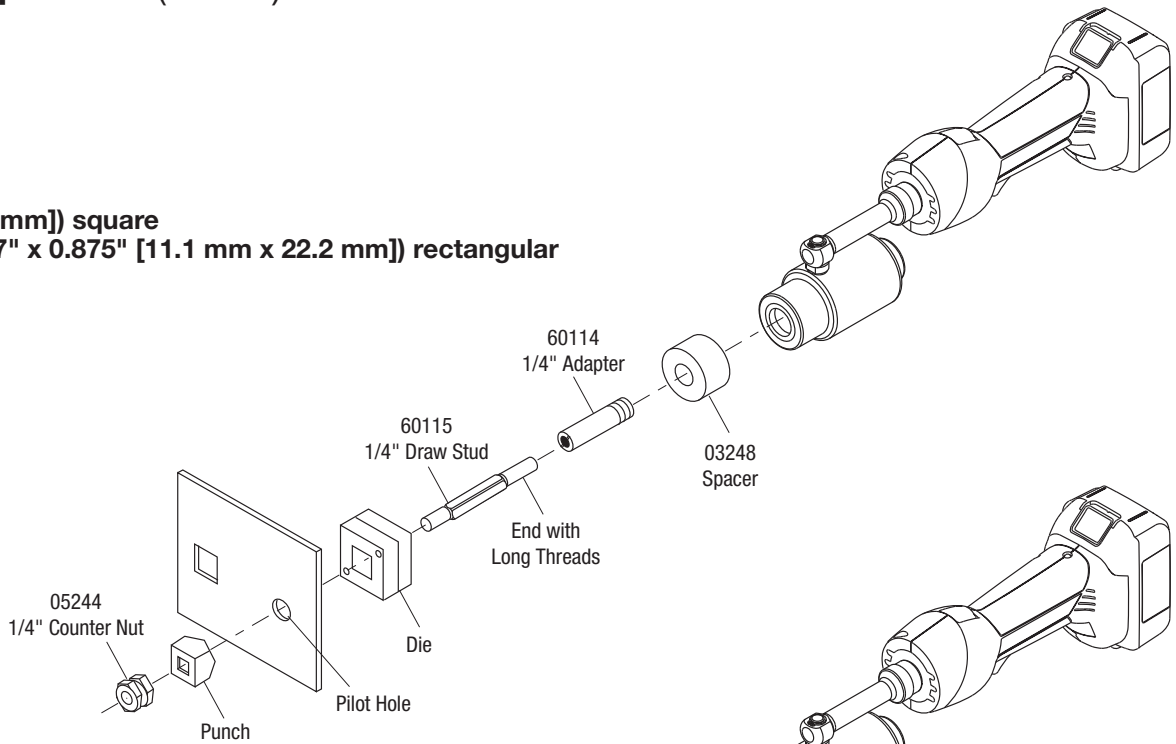

**Punching with 5/8" (0.625" [15.9 mm])  
 through 0.945" [24.0 mm] square  
 0.670" x 0.749" [17.0 mm x 19.0 mm]) rectangular**

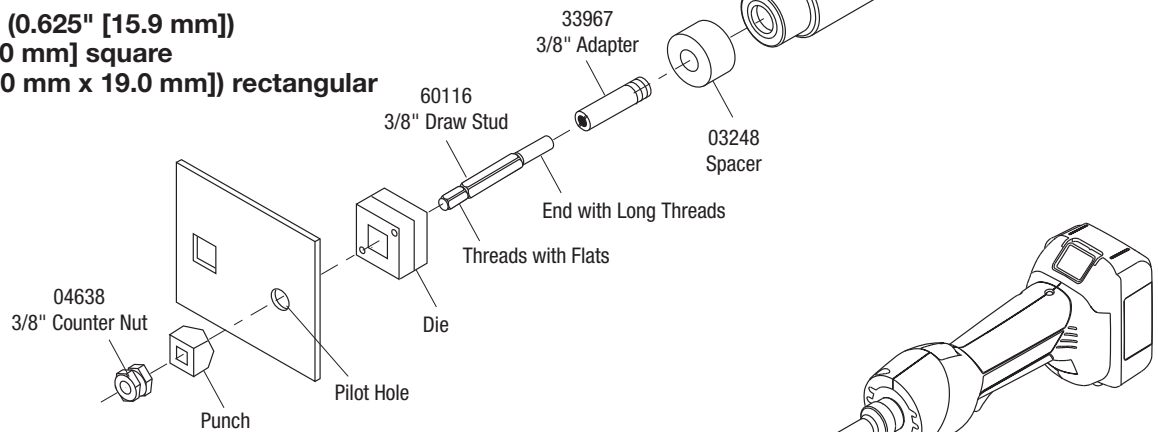

**Punching with 1" [25.4 mm] square  
 0.750" x 1.140" [19.1 mm x 29.0 mm] through  
 1.250" x 1.380" [31.8 mm x 35.1 mm] rectangular**

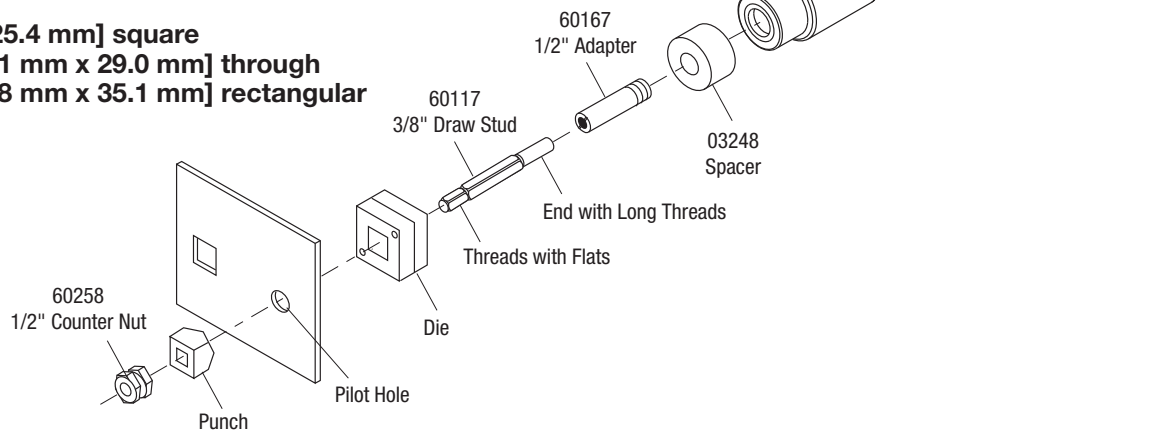

**Setup and Operation (cont'd)**

**Punching with**  
**1.811" [46.0 mm] through 2.677" [68.0 mm] square**  
**1.312" x 2.625" [33.3 mm x 66.7 mm] rectangular**  
**through 1.378" x 2.559" [35.0 mm x 65.0 mm] rectangular**

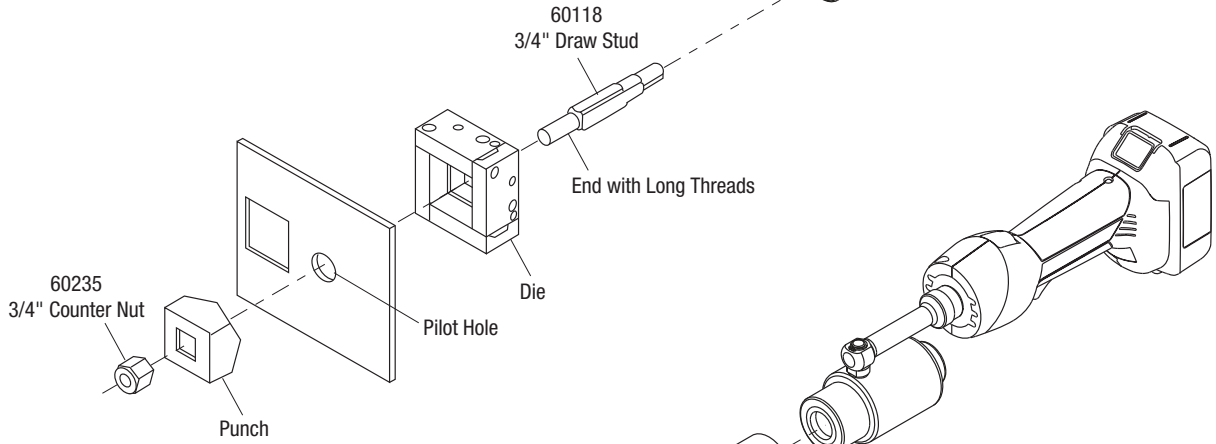

**Punching with**  
**"D", Double "D",**  
**and Key sizes**

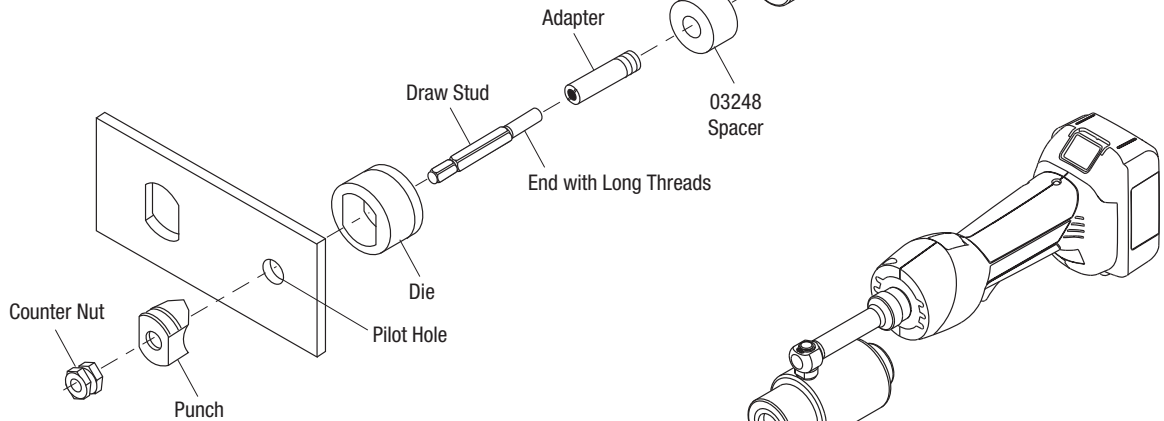

**Punching with**  
**Electronic Connector**  
**Panel Punches**

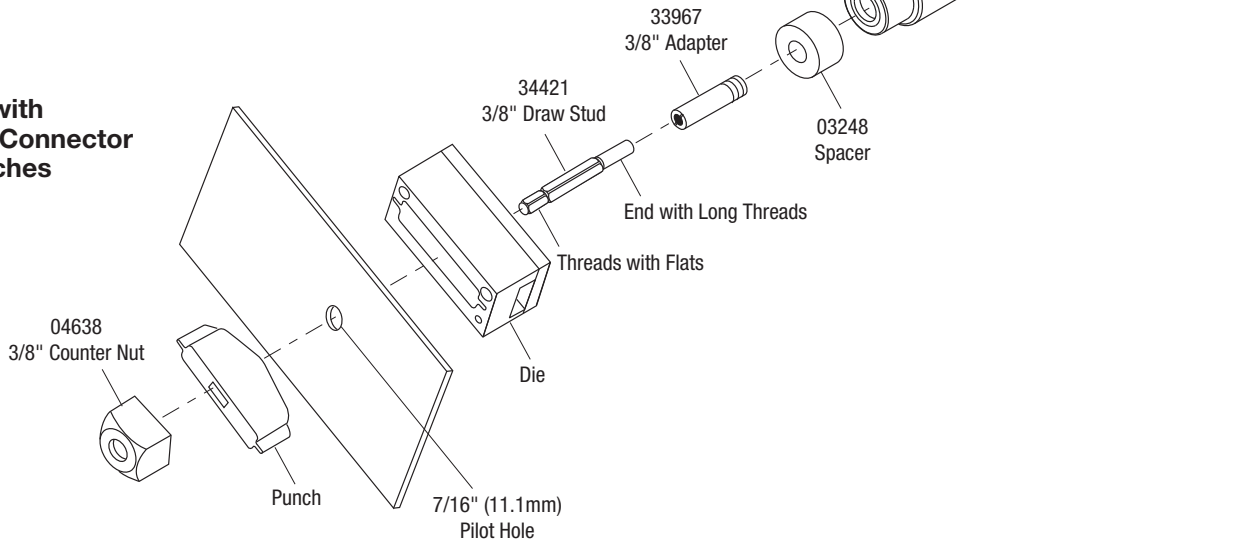

**Capacity and Draw Stud Selection Guide**

<b>MILD STEEL</b>						
<b>Standard and Slug-Buster Punches / Draw Studs</b>						
<b>Steel Gauge</b>	<b>PIPE AND CONDUIT SIZE</b>					
	<b>1/2"</b>	<b>3/4" to 1-1/4"</b>	<b>1-1/2" to 2"</b>	<b>2-1/2" to 3"</b>	<b>3-1/2" to 4"</b>	<b>5" to 6"</b>
<b>10 ga.</b> (0.134", 3 mm)	A, F, H	B, F	B	C	N/A	N/A
<b>12 ga.</b> (0.104", 2.5 mm)					C,G	
<b>14 ga.</b> (0.074", 2 mm)						C,G

<b>STAINLESS STEEL</b>			
<b>Slug-Splitter and Large 3-Point Punches / Draw Studs</b>			
<b>Steel Gauge</b>	<b>PIPE AND CONDUIT SIZE</b>		
	<b>1/2"</b>	<b>3/4" to 1-1/4"</b>	<b>1-1/2" to 2"</b>
<b>10 ga.</b> (0.134", 3 mm)	D, F	E, F	N/A
<b>12 ga.</b> (0.104", 2.5 mm)			E
<b>14 ga.</b> (0.074", 2 mm)			

<b>MILD STEEL</b>	
<b>Electronic Connector Punches</b>	
<b>Steel Gauge</b>	RS232, 229, 231, 234, 238
<b>16 ga.</b> (0.0598", 1.5 mm)	33967 adapter, 1924AA spacer

**Key**

<b>Item</b>	<b>Draw Stud and Hardware</b>	
	<b>Catalog No.</b>	<b>Description</b>
A	1614SS	3/8" draw stud
B	31872	3/4" x 4.03" draw stud
C	2113B	3/4" x 5.38" draw stud
D	29451	7/16" x 4.25" draw stud (stainless steel)
E	29452	3/4" x 5.5" draw stud (stainless steel)
F	1924AA	7/8" spacer
G	1557AA	1-1/8" x 3" punch sleeve
H	33967	3/4-3/8 adapter

## Maintenance

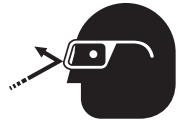
	<b>⚠ WARNING</b>
	<p>Wear eye protection when operating or servicing this tool.</p> <p>Failure to wear eye protection could result in serious eye injury from flying debris or hydraulic oil.</p>

	<b>⚠ WARNING</b>
	<p>Skin injection hazard:</p> <p>Do not use hands to check for oil leaks. Oil under pressure easily punctures skin. If injured, seek medical attention immediately to remove oil.</p> <p>Failure to observe this warning could result in serious injury, gangrene, or death.</p>

	<b>⚠ WARNING</b>
	<p>Do not use solvents or flammable liquids to clean the tool body. Solvents or flammable liquids could ignite and cause serious injury or property damage.</p>

	<b>⚠ WARNING</b>
	<p>Pinch points:</p> <ul style="list-style-type: none"> <li>• Remove battery before changing dies, adapters, or jaws.</li> <li>• Keep hands away from the tool head when punching.</li> </ul> <p>Failure to observe these warnings could result in severe injury or death.</p>

<b>IMPORTANT</b>
Relief valve adjustments must be done by an authorized service center.

### Daily

#### Before use:

1. Inspect the tool for wear or damage, such as cracks, gouges, or chips.
2. Inspect the tool for damage or leaks.
3. Inspect the rotation of the head assembly. Fully return the ram. The head should rotate freely. If damage is detected, send the tool to a Greenlee Authorized Service Center for inspection.

#### After use:

1. Use a damp cloth and mild detergent to clean the housing. Allow the housing to dry.
2. Fully return the ram. Place the tool in the carrying case and store in a cool, dry place.
3. If necessary, recharge the batteries. Refer to the instructions supplied with the battery charger.

### Monthly

1. Thoroughly clean all surfaces.
2. Check the oil level.

### Annually or After 10,000 Punches

1. Replace the hydraulic oil.
2. Send the tool to a Greenlee Authorized Service Center for inspection.

### Checking the Oil Level

1. Remove the screws holding the housing cover together.
2. Point the tool head downward and remove the oil reservoir plug. Fill reservoir if necessary.
3. Replace the oil plug and housing cover.

*Note: For Warranty Service or Repair, contact Greenlee customer service at 800-435-0786.*

## Troubleshooting

### Before You Begin

1. Make sure that the battery is charged. Recheck the battery after several minutes to make sure the battery is holding its charge.
2. Use a **nonflammable** contact cleaner or pencil eraser to clean the electrical contacts on the battery and tool.
3. Reinstall the battery and check the tool again.

Problem	Possible Cause	Probable Remedy
Tool is inoperative.	Dirt, contaminants, etc., in ram area of tool.	Clean tool.
	Tool battery contacts damaged.	Reform contacts.
	Tool components worn or damaged.	Return tool to a Greenlee Authorized Service Center.
Motor is inoperative.	Low or uncharged battery.	Try known charged battery. Inoperative battery may be discharged or may have reached life expectancy.
	Broken switch components.	Return tool to a Greenlee Authorized Service Center.
Motor runs but tool will not complete a cycle.	Oil level low.	Return tool to a Greenlee Authorized Service Center.
	Air in hydraulic system.	Pull trigger and hold return button simultaneously. Run for approximately 10 seconds, and then attempt to punch. If unsuccessful, return tool to a Greenlee Authorized Service Center.
	Cold oil.	Pull trigger and hold return button simultaneously to warm oil. Store tool in warm area.
Dies stop during operation.	Oil level low.	Return tool to a Greenlee Authorized Service Center.
	Air in hydraulic system.	Pull trigger and hold return button simultaneously. Hold for approximately 10 seconds.
LED glows for 20 seconds.	Battery charge low.	Charge or replace battery.
Tool loses oil.	Damaged internal seal.	Return tool to a Greenlee Authorized Service Center.

*Note: For Warranty Service or Repair, contact Greenlee customer service at 800-435-0786.*



4455 Boeing Drive • Rockford, IL 61109-2988 • USA • 815-397-7070  
An ISO 9001 Company • Greenlee Textron Inc. is a subsidiary of Textron Inc.

[www.greenlee.com](http://www.greenlee.com)

**USA** Tel: 800-435-0786  
Fax: 800-451-2632

**Canada** Tel: 800-435-0786  
Fax: 800-524-2853

**International** Tel: +1-815-397-7070  
Fax: +1-815-397-9247