

UHDM 1 DOOR MASTER - SERIES

BUL10095
REV. C

ASSEMBLY INSTRUCTIONS FOR CONNECTING INTERLOCK INSTALLATION

ASSEMBLY VIEW OF JOINING HARDWARE AND SEAL BETWEEN MODULES SEE STEP D

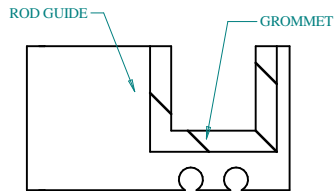

SECTION A-A

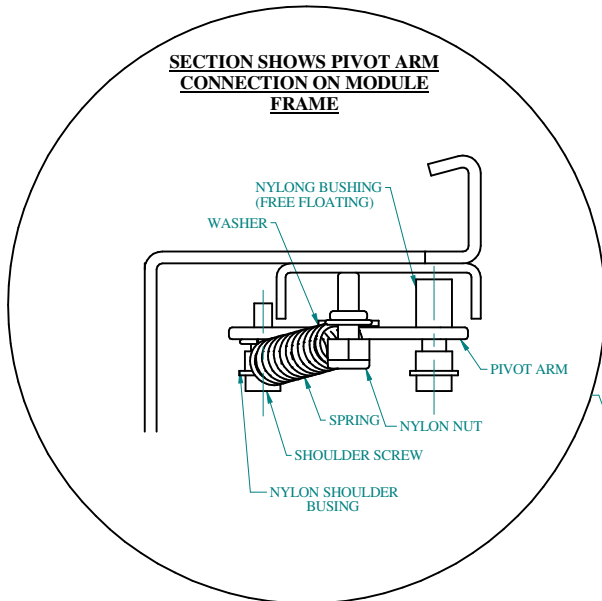
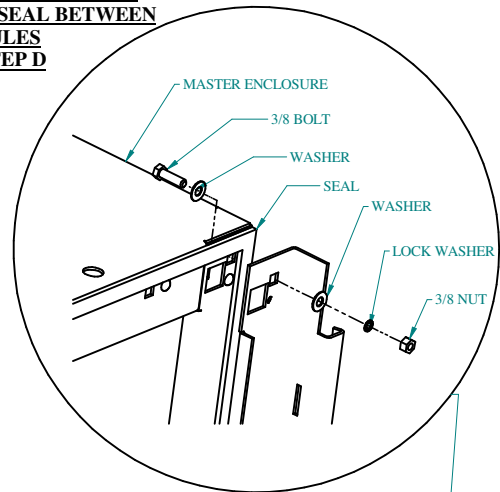

SECTION SHOWS PIVOT ARM
CONNECTION ON MODULE
FRAME

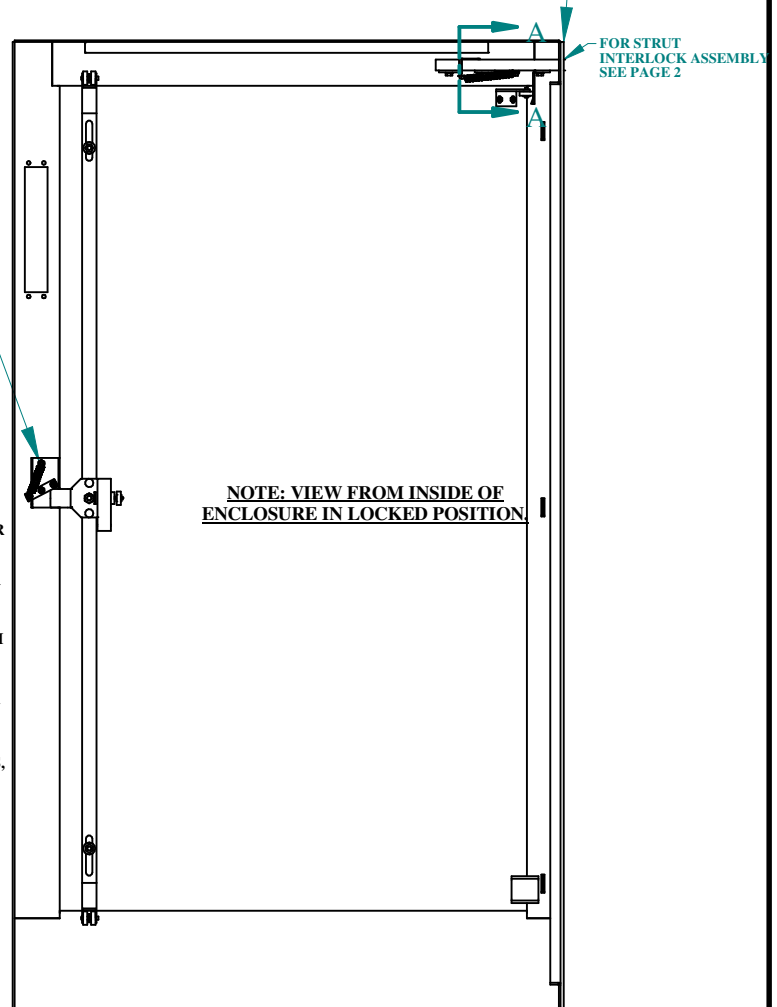

NOTE: VIEW FROM INSIDE OF
ENCLOSURE IN LOCKED POSITION

NOTE FOR CONNECTING:

- (A) POSITION MODULAR SECTIONS WITH THE MASTER MODULE ON THE RIGHT. SLAVE MODULES ARE MOUNTED IN ANY SEQUENCE (SINGLE OR DOUBLE DOOR TO THE LEFT.
- (B) SHIM UNDER MODULES FOR UNEVEN FLOOR AS REQUIRED TO ALIGN MATING HOLES IN THE SIDES OF MODULES.
- (C) IF BARRIER PLATE USED POSITION SUCH THAT THE GASKET IS SEALING BOTH SIDES OF THE PLATE. *NOTE: BARRIER PLATE WILL COMPLETELY SEAL BETWEEN SECTION. THE MODULES BEYOND THE BARRIER MUST BE INTERLOCKED WITH THE MASTER DISCONNECT SWITCH. A CLEARANCE HOLE MUST BE MADE IN THE BARRIER FOR THE TRANSFER BAR. USE MATING HOLE IN THE ENCLOSURE AS A TEMPLATE FOR SIZE AND LOCATION OF HOLE.
- (D) BOLT THE MODULES TOGETHER USING A 3/8 CAPSCREW, TWO FLAT WASHERS, LOCKWASHER AND A NUT ON EACH HOLE. TIGHTEN TO A TORQUE OF 100 IN-LBS. REFER TO VIEW ABOVE.
- (E) SEAL OFF THE END OF THE LAST SLAVE UNIT WITH A FLAT END PLATE, OR A FORMED END COVER USING A WASHER AND LOCKNUTS. THEN TIGHTEN NUTS TO A TORQUE OF 50 IN-LB.
- (F) USE BONDING STUDS (PROVIDED INSIDE ALL THE OPENINGS AND ALL THE DOORS) TO ENSURE CONTINUITY OF GROUND BETWEEN ALL POINTS IN THE ENCLOSURE. A BONDING WIRE MUST BE USED BETWEEN THESE STUDS.

TOOL BOX	9/16" Socket Wrench	9/16 Open End Wrench

HAMMOND
MANUFACTURING™
ENCLOSURES

UHDM 1 DOOR MASTER - SERIES

BUL10095
REV. C

ASSEMBLY INSTRUCTIONS FOR CONNECTING INTERLOCK INSTALLATION

- (A) PULL THE STEEL STRUT (PART 1) FORWARD FROM THE ATTACHED SLAVE DISCONNECT ENCLOSURE.
- (B) INSTALL THE STOP BRACKET (PART 2) TO THE STEEL STRUT, 1.00" (25.4mm) FROM THE END AS SHOWN. USE 1/4 - 20 HEX SCREW, SPRING NUT AND LOCK WASHERS (PARTS 5, 6 & 7).
- (C) FASTEN THE SECOND STOP BRACKET 1.00" (25.4mm) OVER FROM THE ROD GUIDE AS SHOWN. USE 1/4 - 20 HARDWARE (PARTS 5, 6 & 7).
- (D) WITH DOOR FULLY CLOSED AND SECOND STOP BRACKET OVER TIGHT AGAINST THE ROD GUIDE, INSTALL THE DOOR STRIKE BRACKET
- (E) FASTEN THE SPRING (PART 4) AS SHOWN. SLIP ONE END OVER THE HOOK ON THE ROD GUIDE AND FASTEN THE OTHER END TO THE STRUT. USE 1/4-20 RH SCREW, SPRING NUT, LOCK WASHER AND A SEALING WASHER (PARTS 6,7,8,9).

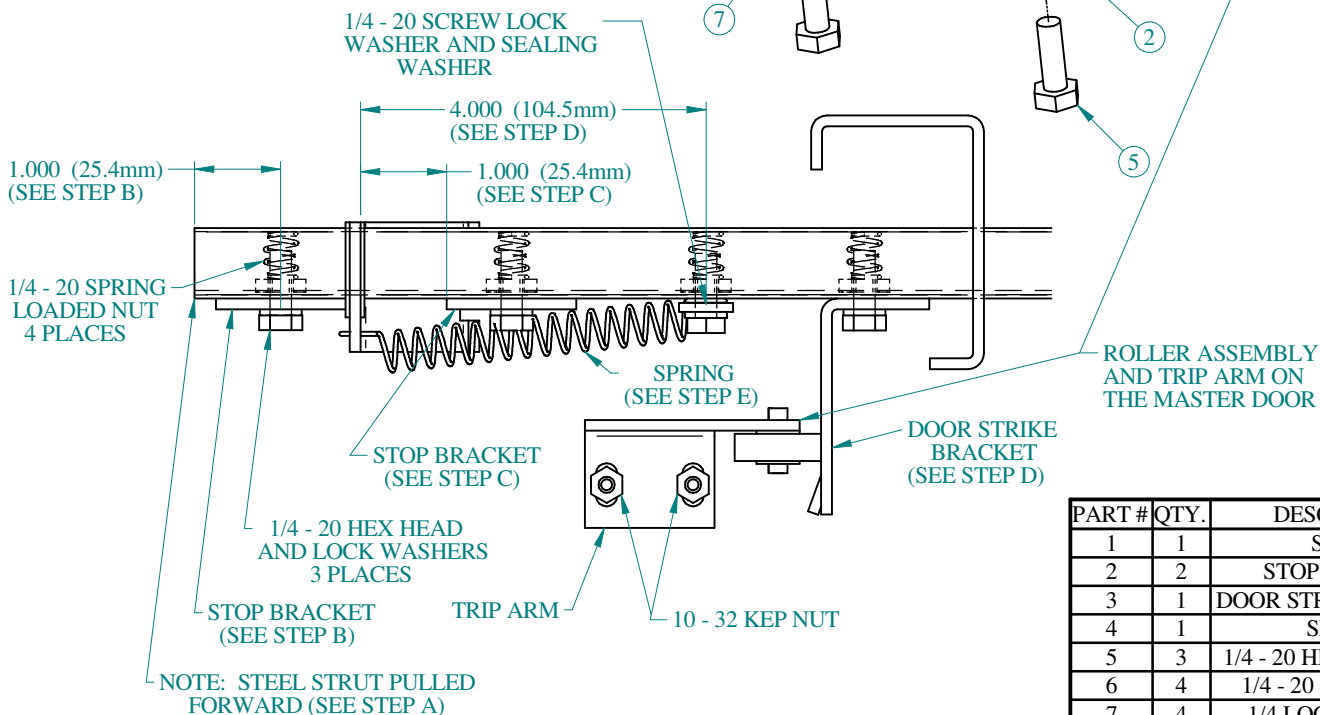
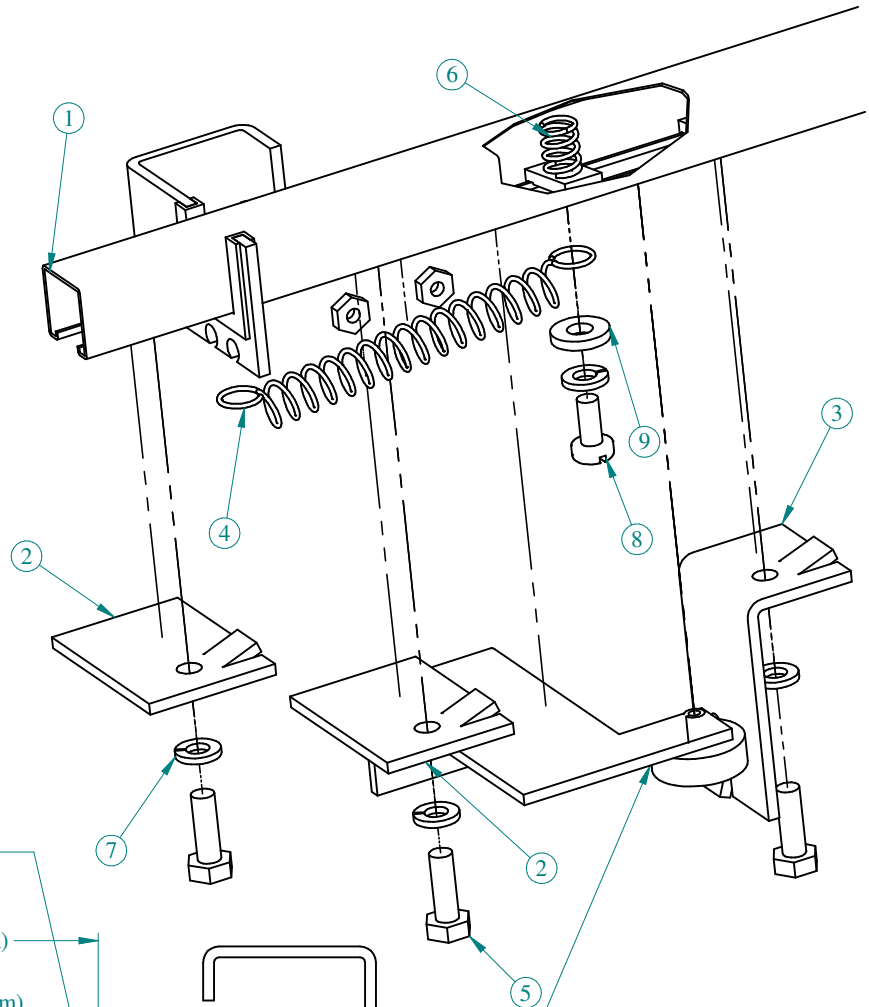

PART #	QTY.	DESCRIPTION
1	1	STRUT
2	2	STOP BRACKET
3	1	DOOR STRIKE BRACKET
4	1	SPRING
5	3	1/4 - 20 HEX HD SCREW
6	4	1/4 - 20 SPRING NUT
7	4	1/4 LOCK WASHER
8	1	1/4 - 20 RD HD SCREW
9	1	1/4 SEALING WASHER

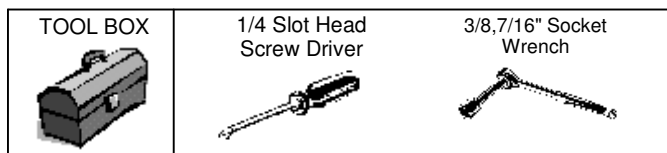

HAMMOND
MANUFACTURING™
ENCLOSURES