

| | |
|------------|-----------------|
| SAP P/N# | ENGINEERING NO. |
| 1201090004 | ERWAAJ3000C050 |

AUX VIEW
SCALE 3:4

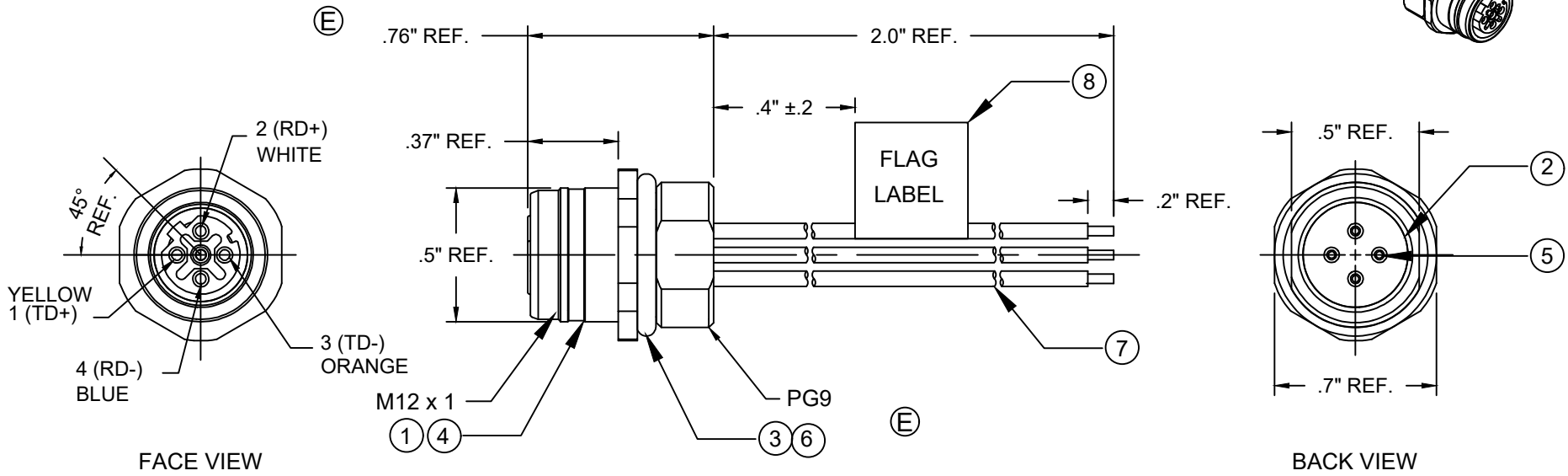

- NOTES:
1. MATERIAL: AS NOTED
 2. FINISH: AS NOTED
 3. ELECTRICAL:
VOLTAGE: 30V
CURRENT: 1.5A
 4. TEMP RATING: -10°C TO 80°C
 5. PROTECTION: IP67, IP69K (WHEN MATED)
 6. UL LISTED, FILE: E2006520
 7. ALL DIMS ARE FOR REFERENCE UNLESS OTHERWISE NOTED

ERWAAJ3000C050

wire type #22-1 PVC

cable length 050----5 Centimeters 100----10 Centimeters

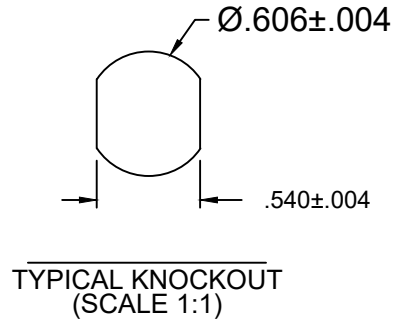

| | | | |
|------|--------------------------|--------------|------------------|
| 8 | LABEL | PLASTIC FILM | BLACK/YELLOW |
| 7 | WIRE | PVC | SEE WIRE DIAGRAM |
| 6 | EPOXY | PUR | -- |
| 5 | SOCKET CONTACT | COPPER ALLOY | NICKEL |
| 4 | GASKET | VITON | RED |
| 3 | O-RING | NITRILE | BLACK |
| 2 | INSERT, D-CODE | PUR | BLACK |
| 1 | SHELL: FRONT PANEL MOUNT | BRASS | NICKEL |
| ITEM | DESCRIPTION | MATERIAL | FINISH |

| | | | | |
|--|---|------------------------|---|---|
| FUNCTIONAL SYMBOLS F=0 E=0 P=0 | THIS DRAWING CONTAINS INFORMATION THAT IS PROPRIETARY TO MOLEX ELECTRONIC TECHNOLOGIES, LLC AND SHOULD NOT BE USED WITHOUT WRITTEN PERMISSION | | | |
| | DIMENSION UNITS | SCALE | | CURRENT REV DESC: UPDATED NOTES AND ADDED IP69K, UPDATED DIMENSIONS, ADDED MATERIAL NUMBER DESIGNATIONS |
| | INCH/MM | NTS | | |
| | GENERAL TOLERANCES (UNLESS SPECIFIED) | | | |
| DIVISIONAL SYMBOLS | | mm | INCH | EC NO: 639759 DRWN: ALEON01 2020/06/12 CHK'D: CCHRSTKA 2020/06/18 APPR: BWOODMAN 2020/06/18 |
| | 4 PLACES | ±---- | ±---- | |
| | 3 PLACES | ±---- | ±---- | |
| | 2 PLACES | ±---- | ±---- | |
| 1 PLACE | ±---- | ±---- | INITIAL REVISION: | |
| 0 PLACES | ±---- | ±---- | DRWN: VOU 2009/08/14 APPR: JFMURPHY 2009/08/21 | |
| ANGULAR TOL ± ---- ° | | | | |
| DRAFT WHERE APPLICABLE MUST REMAIN WITHIN DIMENSIONS | | THIRD ANGLE PROJECTION | DRAWING | SERIES |
| | | | A-SIZE | 120109 |
| | | DOCUMENT NUMBER | | DOC TYPE/DOC PART |
| | | SD-120109-007 | | PSD 001 |
| | | MATERIAL NUMBER | | REVISION |
| | | SEE CHART | | E |
| | | CUSTOMER | | SHEET NUMBER |
| | | GENERAL MARKET | | 1 OF 1 |