

ARTI. ITEM	DESCRIPCION DESCRIPTION
1	4-POLO INSERT MACHO 4P MALE INSERT
2	PASADOR MACHO PIN CONTACT
3	#16/4 SOO CABLE - AMARILLO #16/4 SOO CABLE - YELLOW
4	ANILLO RETENEDOR RETAINING RING
5	TUERCA DE ACOPLAMIENTO COUPLING NUT
6	MEZCLA PVC DE MOLDEO - AMARILLO PVC MOLDING COMPOUND - YELLOW
7	BANDERA DE CLASIFICACION LABEL - FLAG
7	BOLSA PLASTICA LEER NOTA 6 POLY-BAG SEE NOTE 6

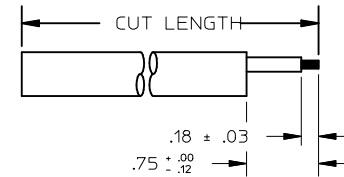

PREPARACION DE CABLE  
LEER NOTAS 1,2,3  
CABLE PREPARATION - SEE NOTES 1,2,3

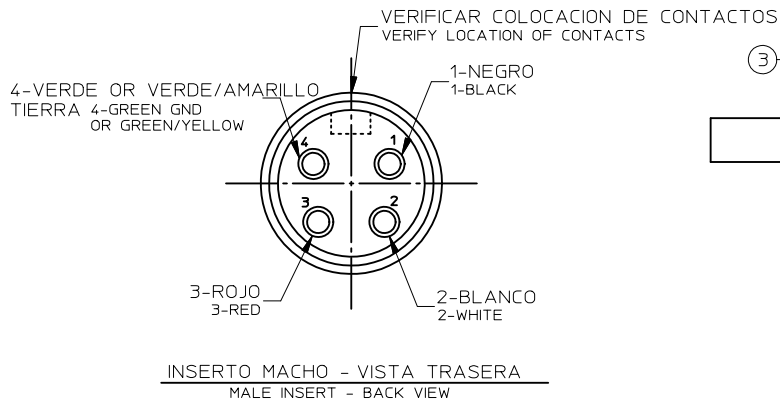

INSERTO MACHO - VISTA TRASERA  
MALE INSERT - BACK VIEW

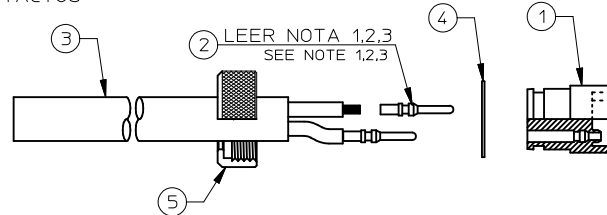

ENSAMBLE DE CONECCION  
CONNECTION ASSEMBLY

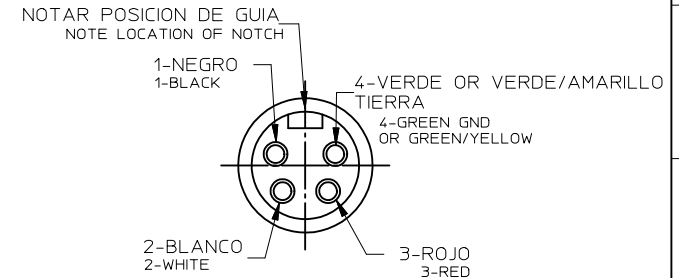

INSERTO MACHO - VISTA FRONTAL  
MALE INSERT - FRONT VIEW

NOTAS:

- NOTES:
- TODAS LAS HEBRAS DE CONDUCTORES DEBEN SER INSERTADAS Y REMACHADAS EN EL CONTACTO.  
ALL STRANDS OF EACH CONDUCTOR MUST BE FULLY CRIMPED IN CONTACT.
  - CADA REMACHE TIENE QUE RESISTIR 30 LBS. MINIMO EN EL HALAR.  
EACH CRIMP MUST WITHSTAND A MINIMUM PULL-OUT FORCE OF 30 LBS.
  - INSTALAR CONTACTOS REMACHADOS/CONDUCTORES EN EL INSERT APROPIADO SEGUN LA POSICION EN VISTA TRASERA.  
INSTALL CRIMPED CONTACTS/CABLE CONDUCTORS INTO INSERT AS SHOWN IN BACK VIEW.
  - PARA DIMENSIONES E INFORMACION EN MOLDEO LEER -0- REVISAR STD - 142.  
FOR DIMENSIONAL AND MOLDING INFORMATION SEE STD - 142.
  - INCLUIR EN BOLSA PLASTICA EL CABLE Y CARTA CON NUMERO DE PARTE.  
INCLUDE PORTABLE CORD AND P/N CARD IN POLY-BAG.
  - USAR BOLSA PLASTICA COMO INDICADO: -0802 PARA CABLES NO MAS DE 3'-0", -0803 PARA CABLES NO MAS DE 15'-0", -0801 PARA CABLES MAS DE 15'-0".  
USE POLY-BAG AS FOLLOWS: -0802 UP TO 3'-0", -0803 UP TO 15'-0", -0801 OVER 15'-0".

ROCIAR COMPLETAMENTE SUPERFICIE DE INSERTO EN AREA DETRAS TUERCA DE ACOPLAMIENTO Y PRIMERAS 2" DE CABLE CON METIL ETIL QUETON ( M E K ) INMEDIATAMENTE ANTES DE APLICACION DE MOLDEO. VERIFICAR ATADURA CUANDO PARTES HAN ENFRIADO.  
THOROUGHLY SPRAY THE POKE HOME INSERT ON SURFACE AREA BEHIND COUPLING NUT AND ALSO THE FIRST 2" OF THE OUTER JACKET OF CORD WITH METHYL ETHYL KETONE IMMEDIATELY BEFORE LOADING INTO MOLD. CHECK BONDING AFTER PARTS HAVE COOLED.

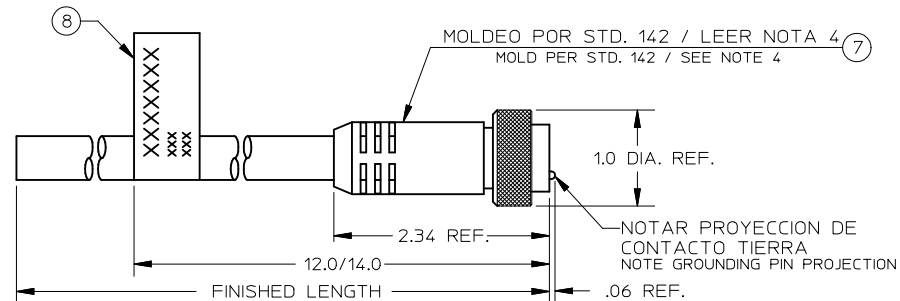

APLICACION DE MOLDADURA  
APPLICATION OF PLASTIC MOLD

SEE BOM FOR PARTS LIST  
LEER EL B.O.M. PARA COMPONENTES

CHANGE WIRE COLOR EC NO: MNA2010-0657 DRAWN BY: BRUPERT 2010/05/03 CHKD BY: CHKD:BW 2010/05/03 APPR: JFMURPHY 2010/05/19	DESCRIPTION REV	QUALITY SYMBOLS ▽=0 ▽=0	GENERAL TOLERANCES (UNLESS SPECIFIED)		DIMENSION STYLE IN/MM		SCALE 1:1	DESIGN UNITS INCH	THIRD ANGLE PROJECTION	
			mm	INCH	DRAWN BY BRUPERT	DATE 2010/05/03	TITLE 4P MALE INSERT ASSEMBLY 4 POLO INSERTO MACHO MINI-CHANGE	MATERIAL NO. 411XXS		SHEET NO. 1 OF 1
DRAFT WHERE APPLICABLE MUST REMAIN WITHIN DIMENSIONS			ANGULAR ±1/2°		APPROVED BY JFMURPHY		DATE 2010/05/17		MATERIAL NO. 411XXS	
THIS DRAWING CONTAINS INFORMATION THAT IS PROPRIETARY TO MOLEX INCORPORATED AND SHOULD NOT BE USED WITHOUT WRITTEN PERMISSION										