

THIS IS A C.A.D. GENERATED DRAWING  
DO NOT MAKE MANUAL REVISIONS TO MASTER.

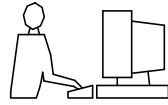

\* UNLESS OTHERWISE SPECIFIED TOLERANCES  
ON DECIMAL IS: ANGLE  
UNIT: MM X.  
X.X

ISSUE NUMBER

ORIGINAL ①

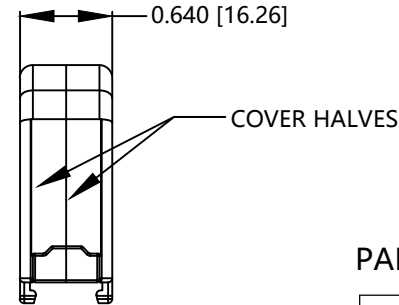
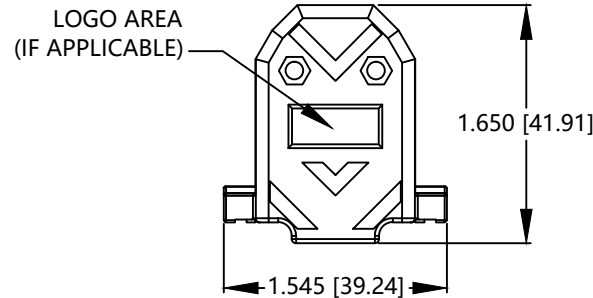
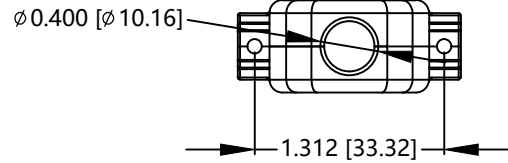

**PART NUMBER INFORMATION**

PART#	LOGO STYLE	SUPPLIED
C88E310000	NO LOGO	PACKAGED

**CONNECTOR COVER:**  
1.MATERIAL : ABS COMPOUND - UL94HB  
2.FINISH : NICKEL PLATING PER NTC  
SPECIFICATION N/T 000500  
3.DIMENSIONS : INCHES [MM]  
4.TOLERANCE : ±0.015 [0.381]

**COMPRESSION INSERT TREE**  
1.MATERIAL : THERMOPLASTIC  
2.COLOR : BLACK  
3.DUROMETER: 75±5 TYPE A PER ASTM D2240  
4.DIMENSIONS : INCHES [MM]  
5.TOLERANCE : ±0.020 [0.508]

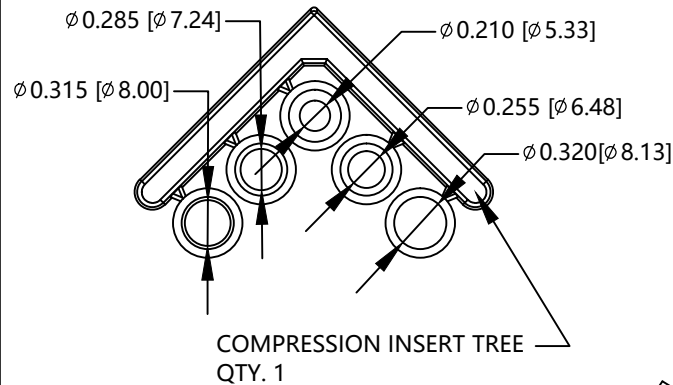

COMPRESSION INSERT TREE  
QTY. 1

 #4-40 X 7/16" FILLISTER HEAD MACHINE SCREW  
MATERIAL - STEEL  
FINISH - BRIGHT ZINC (HEXAVALENT CHROMIUM FREE)  
QTY: 2 EACH

 #4-40 #2 BLANK HEX NUT  
MATERIAL - STEEL  
FINISH - BRIGHT ZINC (HEXAVALENT CHROMIUM FREE)  
QTY: 2 EACH

 #4-40 x 1/2" FILLISTER HEAD CAPTIVE SCREW  
MATERIAL - STEEL  
FINISH - BRIGHT ZINC (HEXAVALENT CHROMIUM FREE)  
QTY: 2 EACH

 #4 SADDLE WASHER  
MATERIAL - STEEL  
FINISH - BRIGHT ZINC (HEXAVALENT CHROMIUM FREE)  
QTY: 2 EACH

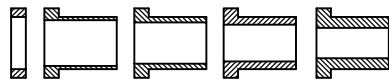

THESE DRAWINGS AND SPECIFICATIONS ARE THE PROPERTY OF MH CONNECTORS AND SHALL NOT BE REPRODUCED, COPIED OR USED AS THE BASIS FOR THE MANUFACTURE OR SALE OF APPARATUS WITHOUT WRITTEN PERMISSION.

DRAWN Henry Pan	DATE 2023/02/27
APPROVED	DATE

SCALE 1:1	SHEET OF 1 OF 1	REV: 1
--------------	--------------------	-----------

DRAWING No  
MHC88E310000



THIS SERIES FULLY CONFORMS TO THE EUROPEAN UNION DIRECTIVES 2015/863/EU AND 2011/65/EU FOR RoHS COMPLIANCY.



**MH CONNECTORS ,  
DIVISION OF EDAC**