

6

5

4

3

2

1

APPROVED: _____

DATE: _____ TITLE: _____

Rev	AWO #	Description	Date	Appr
-		RELEASED	9/25/20	

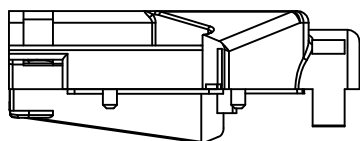
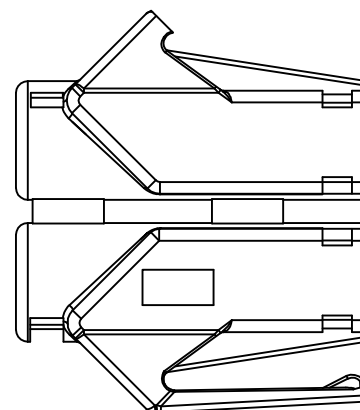
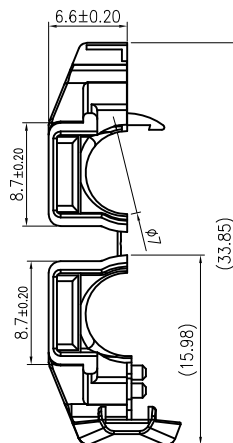
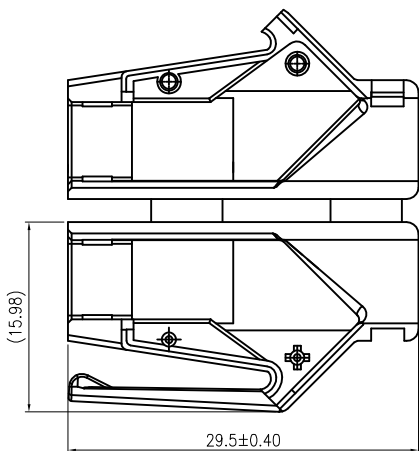
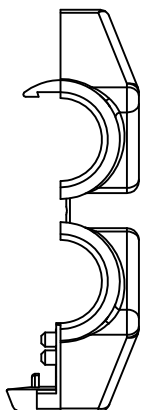
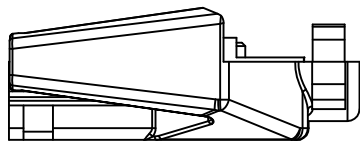

UNLESS OTHERWISE SPECIFIED
 ALL DIMENSIONS ARE MILLIMETERS
 TOLERANCES: EXCEPT AS NOTED

MM	ANGLE
0~15 ± 0.15	± 1°
15~30 ± 0.20	
30~ ± 0.25	

ADAM TECH
 INTERCONNECTS

909 Rahway Avenue,
 Union, NJ 07083
 Phone: 908-687-5000
 Fax: 908-687-5710

SPECIFICATIONS:

Material:
 Insulator: PA66, Glass reinforced, Color: Black
 Environmental:
 Lead free, RoHS compliant



APPROVALS		DATE
DRAWN	LH	9/25/20
CHECKED	AY1	9/25/20
APPROVED		

TITLE MODULAR TELEPHONE PLUG, PLASTIC HOOD			
SIZE X	PART NO. MTP-88-HD-A	REV. -	
REF: S00005C	SCALE: NTS	SHEET 1 OF 1	

6

5

4

3

2

1