

# **YRS SERIES**

## **HAND CRIMP TOOL**

### **Instruction Manual**



## **Preface:**

- 1) The YRS series hand tools are designed to crimp smaller sized open barrel terminals that are side fed and attached to a carrier strip.
- 2) The tool was designed for small production lots, samples, and repairs.
- 3) Each tool includes a specification sheet which includes the tool part number, the contact to be crimped, the specific wire to be used, the required tensile strength, and the strip length for the wire.
- 4) The upper die has two crimp positions for different wire sizes. The die must be set for the wire to be crimped.
- 5) The conductor and insulation barrel crimp heights are not adjustable. Therefore, the wire noted on the tool specification must be used.

## **Precautions:**

- 1) Make sure the correct combination of wire, terminal, and tool are used.
- 2) The tool does not have a release for the ratchet. Once a cycle is started it must be completed. If the terminal is not positioned properly or there is a foreign body stuck in the crimp do not force the handles closed. Doing so will likely break parts on the tool. Instead remove the adjustment pin and the upper die. After removing the die the process can be complete releasing the ratchet.
- 3) Check the following items prior to use:
  - a) Make sure the crimping dies are free from damage, rust, and debris.
  - b) Make sure the ratchet releases smoothly after the crimp is complete.
  - c) Visual inspection of crimped contact and tensile strength are good.
- 4) Do not use the tool for purposes other than crimping.
- 5) Periodically add oil to the moving parts and pins on the tool. If the tool will not be used for long period coat it in oil and store in a rust preventative bag.
- 6) Consult JST if the tool beaks or needs to be repaired.

## Crimping Operation:

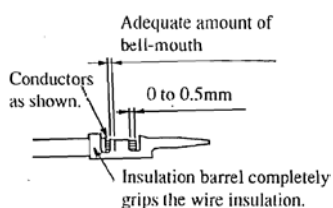
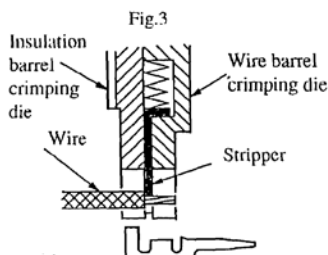
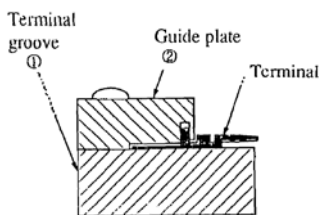
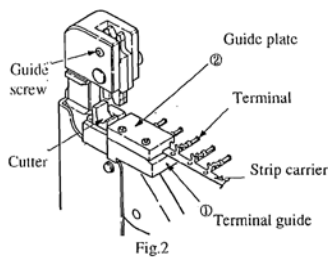
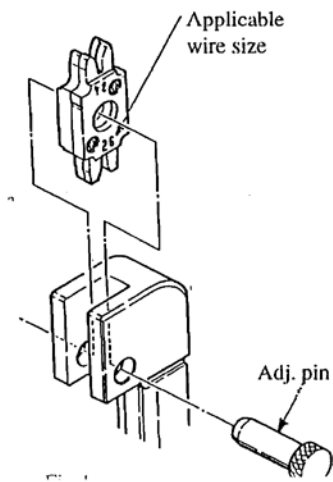

There shall be no unusual burrs.

- 1) Squeeze the handles until the dies are completely closed. The Ratchet will release allowing the handles to open.
- 2) Remove the adjustment pin from the upper die and then remove the upper die from the tool.
- 3) Select the side that matches the wire size that will be used.
- 4) Refer to Fig. 2. Position the upper die and insert it so the guide screw is inserted in the guide groove of the upper die (on the insulation barrel side). The guide screw prevents the die from being inserted the wrong way. Do not remove the guide screw.
- 5) Insert the carrier strip of the terminals into the tool between the terminal guide and the guide plate. The insulation barrel of the terminal must be fed into the groove on the guide plate as shown in Fig. 3. Feed the terminals into the tool by hand until the first terminal is in the crimping position over the anvils.
- 6) With the terminal in the crimping position lightly squeeze the handles together until the upper crimper touches the insulation barrel. Do not put too much pressure on the terminal at this point. Deforming the terminal will prevent the wire from being inserted.
- 7) Insert a stripped wire into the upper die until the insulation of the stripped wire lightly touches the stripper as shown in Fig.4.
- 8) Holding the wire in the correct position squeeze the handles until the ratchet releases.
- 9) Remove the terminal and make a visual inspection of the completed crimped terminal.

## Name of each part:

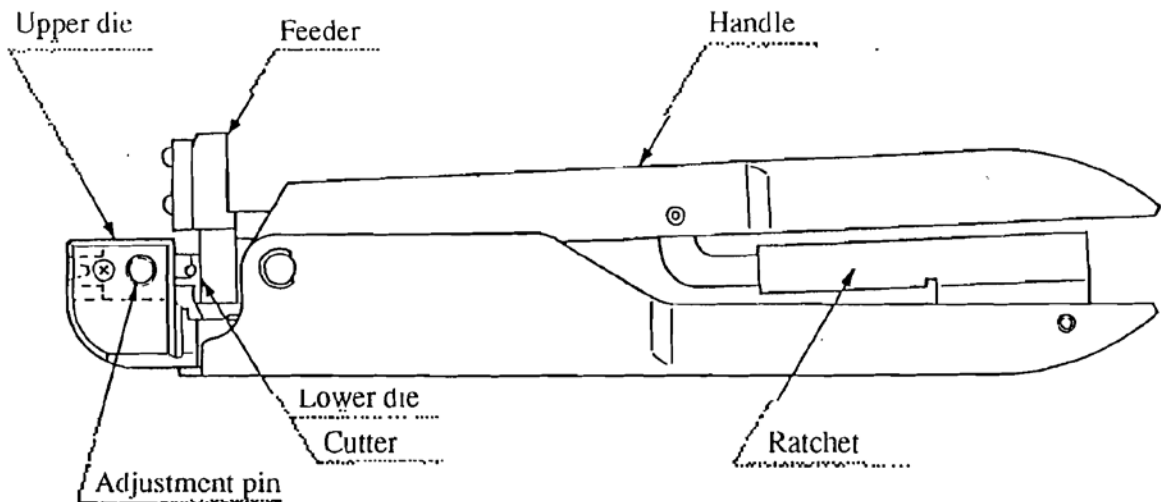

## Caution:

- 1) Do not squeeze the handles with excessive force. The tools are factory adjusted so that the ratchet will release with only about 20~30 kgf. Excessive pressure may damage or break the dies.
- 2) Be sure the wire does not come off the stripper in the upper die when crimping.
- 3) If it seems as if the cycle will not complete without excessive force stop and remove the adjustment pin from the upper die. This will prevent the dies from being damaged.

In line with a policy of continual product development, JST reserves the right to change the specifications of the goods described in this manual at any time without prior notice.