

# DRMS SERIES

## DIN RAIL MOUNT HYBRID MOTOR STARTERS

DRMS Series Hybrid Motor Starters are intelligent and convenient solutions for controlling 3-phase asynchronous motors. These compact devices can provide up to 6 functions in the same unit: Forward/Reverse, Soft Start/Soft Stop, Motor Overload Protection, and Mains Isolating Relay.

Motor overload detection is based on a thermal load curve. The relays are de-energized when an overload condition is present, ensuring a long service life.



### Features

- 3-phase motors reversing up to 4 kW
- 2-phase soft start/stop
- Up to 4 dials for setting of starting torque, deceleration torque, soft start/stop, and rated motor current
- 4 LEDs for status indication
- Galvanic separated 24 VDC inputs for forward and reverse control
- Reset button on front, with connection for external reset
- Relay indicator output for operation
- Hybrid relay combines benefits of electromechanical relay technology with non-wearing semiconductor technology
- High reliability by temperature monitoring of semiconductors

### Applications

- Reversing operation for door and gate controls, bridge drives and lifting applications with monitoring of blockage
- Conveyor systems with monitoring of blockage
- Actuating drives in process controls with blockage monitoring

## PRODUCT SELECTION

Part Number	Functions
DRMS48D91	Forward/Reverse, Overload Protection
DRMS48D92	Forward/Reverse, Overload Protection, Soft Start/Stop
DRMS48D93	Forward/Reverse, Overload Protection, Soft Start/Stop, Mains Isolating Relay

## SPECIFICATIONS

### Output <sup>(1)</sup>

Description	DRMS48D9x
Operating Voltage L1/L2/L3 [Vrms]	200-480 ± 10%
Nominal Frequency [Hz]	50/60, automatic detection
Peak Reverse Voltage [Vpk]	1500
Overvoltage Limiting [Vrms]	550

<b>Maximum Off-State Leakage Current @ Rated Voltage [mArms]</b>	0.5
<b>Load Current, AC51 [Arms]<sup>(2)</sup></b>	9
<b>Load Current, AC53a: 6-2: 10-30 IEC/EN 60947-4-2 [Arms]<sup>(2)</sup></b>	7.6
<b>Maximum Motor Power [kW] @ 400 VAC</b>	4
<b>Minimum Motor Power [W]</b>	25
<b>Maximum Surge Current [Apk] t = 20 msec</b>	200
<b>Load Limit Integral [A<sup>2</sup>sec] t = 10 msec</b>	200
<b>Starting Voltage</b>	30-80%
<b>Start / deceleration ramp [sec]</b>	1-10
<b>Switchover Delay Time [msec]</b>	250
<b>Max. Fuse Rating per IEC/EN 60947-5-1</b>	25 A gG / gL
<b>Electrical Life</b>	> 10 <sup>7</sup> cycles

## Motor Protection <sup>(1)</sup>

Description	DRMS48D9x
<b>I<sub>e</sub>: 1.5 A to 6.8 A</b>	Class 10 / 10 A
<b>I<sub>e</sub>: 6.9 A to 9.0 A</b>	Class 5
<b>Protection type</b>	Electronic, without thermal memory
<b>Reset</b>	Manual

## Input <sup>(1)</sup>

Description	DRMS48D9x
<b>Control Voltage Range (R, L)</b>	10-30 VDC
<b>Minimum Turn-On Voltage</b>	10 VDC
<b>Must Turn-Off Voltage</b>	8 VDC
<b>Typical Input Current</b>	4 mA
<b>Polarity Reversal Protected</b>	Yes
<b>Manual Reset Voltage Range</b>	10-30 VDC

## Auxiliary Power Supply <sup>(1) (3)</sup>

Description	DRMS48D9x
<b>Voltage Range</b>	24 VDC ±10%
<b>Power Consumption</b>	2 W
<b>Min. Start Up Delay</b>	100 msec
<b>Min. Release Delay</b>	50 msec

## Indicator Outputs <sup>(1)</sup>

Description	DRMS48D9x
<b>Output Type (Ready)</b>	1 Changeover Contact (SPDT)
<b>Switching Capacity to AC 15 per IEC/EN 60947-5-1, NO Contact</b>	3 A / 230 VAC
<b>Switching Capacity to AC 15 per IEC/EN 60947-5-1, NC Contact</b>	1 A / 230 VAC
<b>Thermal Current, I<sub>th</sub></b>	5 A
<b>Electrical Life to AC15 @ 3A, 230 VAC per IEC/EN 60947-5-1</b>	2 x 10 <sup>5</sup> Cycles
<b>Mechanical Life</b>	30 x 10 <sup>6</sup> Cycles
<b>Maximum Switching Frequency</b>	1800 cycles/hr
<b>Max. Fuse Rating per IEC/EN 60947-5-1</b>	4 A gG / gL

## General <sup>(1)</sup>

Description	DRMS48D9x
<b>Device Type</b>	Hybrid Motor Controller
<b>Rated Insulation Voltage</b>	500 V
<b>Overvoltage Category / Contamination Level per IEC/EN 60664-1</b>	4 kV / 2
<b>Ambient Operating Temperature Range</b>	0 to 60 °C
<b>Ambient Storage Temperature Range</b>	-25 to 75 °C
<b>Weight (Typical)</b>	188 g
<b>Housing Color</b>	Black and Light Gray
<b>LED Status Indicators</b>	See Indicators Chart
<b>Protection Degree, Housing</b>	IP40
<b>Protection Degree, Terminals</b>	IP20
<b>Humidity @ 40 °C</b>	93% non condensing
<b>Control Terminal Screw Torque (lb-in/Nm)</b>	3.46 / 0.39
<b>Load Terminal Screw Torque (lb-in/Nm)</b>	5-7 / 0.56-0.79
<b>Control Terminal Wire Capacity</b>	1 x 22-14 AWG (IEC 0.5-2.5 mm <sup>2</sup> ) (stranded/solid)
<b>Load Terminal Wire Capacity</b>	1 x 30-12 AWG (IEC 0.05-4 mm <sup>2</sup> ) (stranded/solid)



## GENERAL NOTES

<sup>(1)</sup> All parameters at 25°C unless otherwise specified.

<sup>(2)</sup> To achieve maximum ratings there must be a minimum spacing of 0.9 in (22mm) between the devices in free air (see derating curves).

<sup>(3)</sup> For reliable operation the 24 VDC auxiliary power supply needs to be fully stable during the entire operation of the device. Removing this voltage while the output is under load could cause permanent damage to the device.

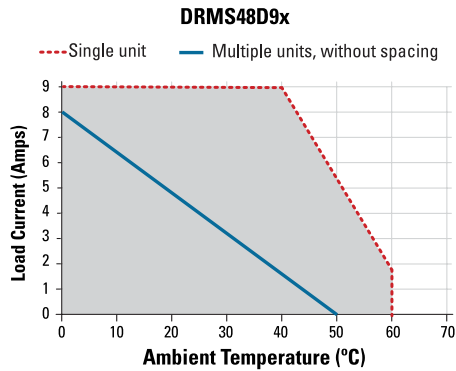
## Additional Notes

- This device is intended for use on supply systems with a maximum voltage from phase to ground of 300 V (e.g. for a three phase-four wire system 277/480 V or on a three phase-three wire systems of 240 V), rated impulse withstand voltage of max. 4 kV.
- Suitable for use on a circuit capable of delivering not more than 5000 rms symmetrical Amperes, 480 Volts maximum when protected by class CC, J or RK5 fuse rated maximum 20 A.
- For use in pollution degree 2 Environment or equivalent.
- The control circuits of this device shall be supplied by an isolated 24 VDC power supply which output is protected with a fuse rated max. 4 Adc.

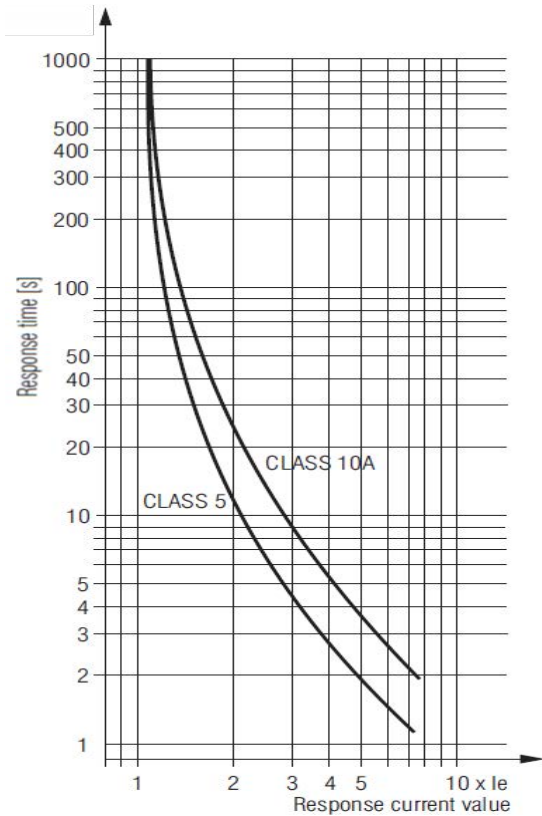
- For installations according to Canadian National Standard C22.2 No. 14-13 (cUL Mark only) and supply voltages above 400V:
  - For 415 V max. supply voltage, transient surge suppression devices shall be installed on the line side of this equipment and shall be rated 240 V (phase to ground), 415 V (phase to phase), suitable for overvoltage category III, and shall provide protection for a rated impulse withstand voltage peak of 4 kV.
  - For 480 V max. supply voltage, transient surge suppression devices shall be installed on the line side of this equipment and shall be rated 277 V (phase to ground), 480 V (phase to phase), suitable for overvoltage category III, and shall provide protection for a rated impulse withstand voltage peak of 4 kV.



## THERMAL DERATE INFORMATION



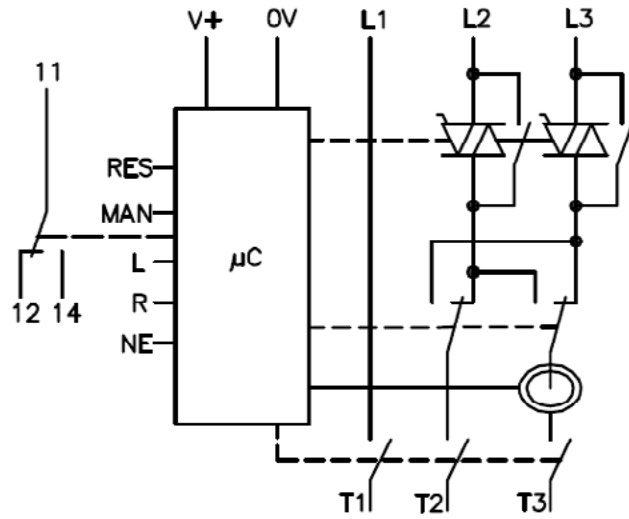
## MOTOR OVERLOAD PROTECTION CURVES



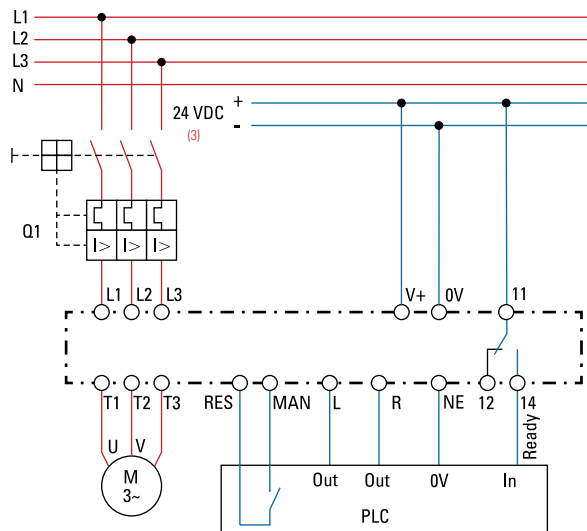


**TABLE 3. Connection Terminals**

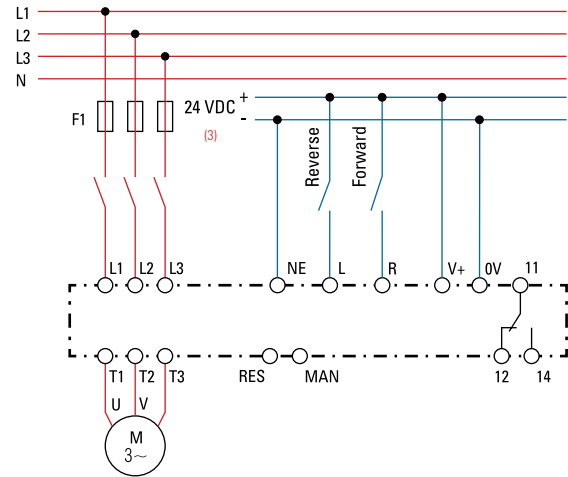
Terminal Designator	Description
V+	Auxiliary voltage +
0V	Auxiliary voltage -
R	Control input Forward
L	Control input Reverse
NE	Earth connection control input
MAN	Input for remote Reset
RES	Output for remote Reset
11, 12, 14	Indicator relay for operation
L1	Phase voltage L1
L2	Phase voltage L2
L3	Phase voltage L3
T1	Motor connection T1
T2	Motor connection T2
T3	Motor connection T3



**Motor control by PLC**



**Motor control by switches**



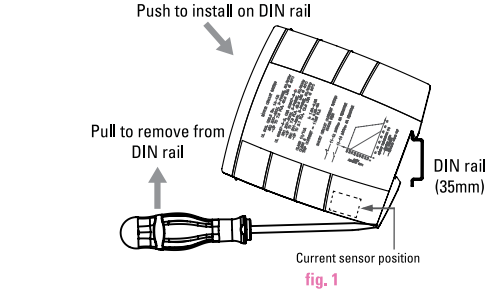


## INSTALLATION INSTRUCTIONS

- Install the motor starter on the DIN rail, as shown on fig. 1.
- Wire the motor starter to the control side. AWG #22 (0.5mm<sup>2</sup>) minimum, AWG #14 (2.5mm<sup>2</sup>) maximum.
- Wire the motor starter to the output side. AWG #30 (0.05mm<sup>2</sup>) minimum, AWG #12 (4 mm<sup>2</sup>) maximum (stranded/solid).
- Maximum terminal screw torque control side 3.46 lb-in (0.39 Nm) & output side 5-7 lb-in (0.564-0.79 Nm).
- Use 60°C / 75°C copper conductors only.
- If multiple units are installed, be sure to follow derating curves.



When designing circuits with this motor starter unit, components that generate magnetic fields like contactors, transformers, or high current wires, should not be placed close to the current sensor.



**WARNING! Latching system could be damaged if product is removed incorrectly out of the DIN rail.**

### Safety Notes:

- Never clear a fault when the device is switched on.
- The user must ensure that the device and the necessary component are mounted and connected according to the locally applicable regulations and technical standards (UL, VDE, TÜV, BG).
- Adjustments may only be carried out by qualified specialist staff and the applicable safety rules must be observed.
- After a short circuit the motor starter is damaged and has to be replaced (Assignment type 1).
- If several motor starter devices are protected together, the sum of the motor currents must not exceed 25 A.



## SETUP PROCEDURE

1. Wire the motor and the motor starter device according to the wiring diagrams examples. A forward (clockwise) rotating field is assumed for normal operation. A anti-clockwise rotating field triggers a fault message.
2. Turn T<sub>ON</sub>/T<sub>OFF</sub> dial fully clockwise, M<sub>ON</sub> and M<sub>OFF</sub> dials fully anti-clockwise, and I<sub>e</sub> dial to the required current.
3. Connect voltage and start the motor using control inputs R and L.
4. The starting time is set by turning the T<sub>ON</sub> dial anti-clockwise and the starting speed is set by turning the M<sub>ON</sub> dial clockwise to the desired value. If set correctly, the motor shall swiftly accelerate to the nominal speed.



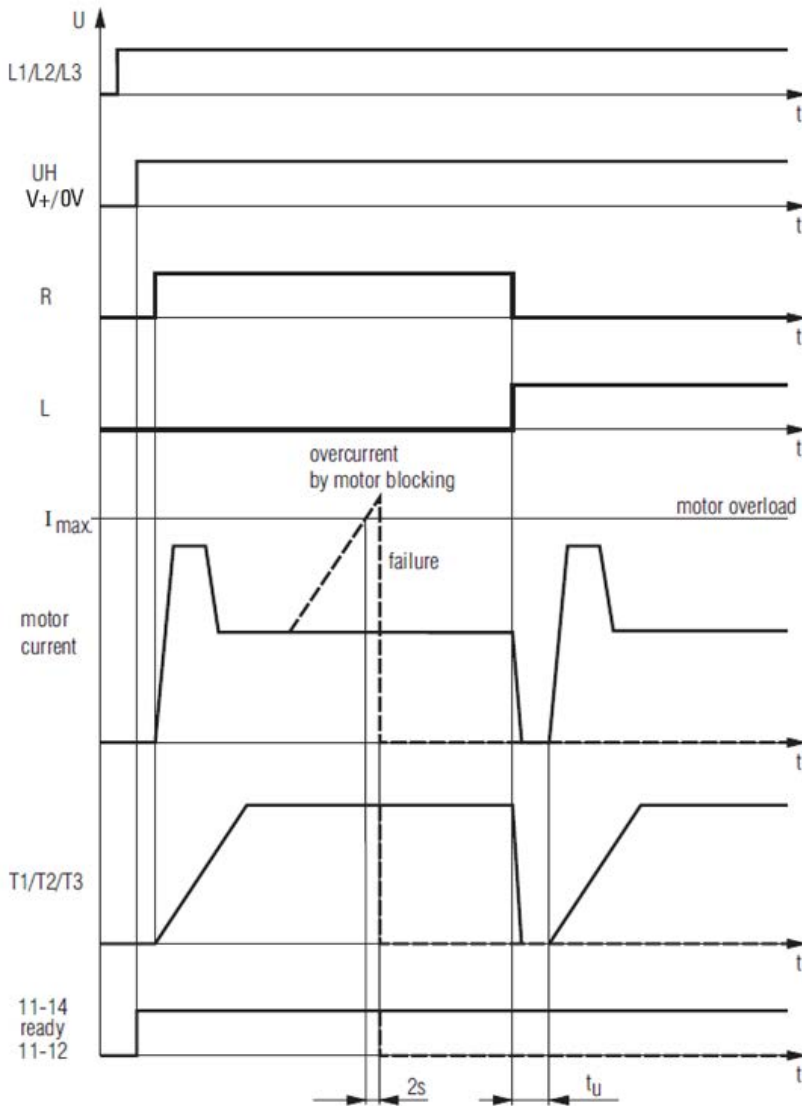
fig. 2

- **MON:** Starting torque at Soft Start, 30 to 80 %
- **MOFF:** Deceleration torque at Soft Stop, 30 to 80 %
- **TON, OFF:** Starting / Deceleration ramp, 1 to 10 s
- **Ie:** Nominal motor current, 1.6 to 9.0 Arms

Indicator	LED Color	Status	Description
PWR	Green	Permanent ON	Auxiliary supply connected.
R	Yellow	Permanent ON Flashing	Forward, power semiconductors bridged. Forward, ramp operation.
L	Yellow	Permanent ON Flashing	Reverse, power semiconductors bridged. Reverse, ramp operation.
ERR	Red	Flashing 1 pulse 2 pulses 3 pulses 4 pulses 5 pulses 6 pulses 7 pulses 8 pulses	Error detected: Over temperature on semiconductors. Wrong mains frequency. Phase reversal detected. At least 1 phase is missing. Motor overcurrent detected. Mains isolating relay not disconnected. Incorrect measurement circuit. Motor protection has responded.



## FUNCTION DIAGRAMS



$t_u$  = switchover delay time  
 $t_p$  = overload response time according to characteristic class 10A or 5



## DEVICE OPERATION

### Forward/Reverse Control

Forward (clockwise) and reverse (anticlockwise) rotation can be selected via control inputs R and L respectively. The input signal detected first is executed if both inputs are applied simultaneously. After the detected signal is cancelled, the rotational direction is reversed via the Soft Start function. These control inputs have a common isolated ground connection NE.

### Soft Start

Two motor phases are switched using phase-angle control to allow a steady increase of the phase currents. The motor torque increases in the same manner when ramping up. This operation ensures the motor starts smoothly and helps to extend the life of the motor and the motor starter. The ramp up time  $T_{on}$  and starting torque  $M_{on}$  can be adjusted via a rotary dial at the front.

### Soft Stop

The Soft Stop function extends the natural run down time of the motor starter to allow for a smooth stop. The ramp down time  $T_{off}$ , which is equal to the ramp up time, and the deceleration torque  $M_{off}$  can be adjusted via a rotary dial at the front.

### Motor Overload Protection

The thermal load of the motor is calculated using a thermal model (see Thermal Overload Protection Curves). The nominal motor current  $I_e$  can be adjusted via a potentiometer on the front. To calculate the thermal load the current is measured in phase T3. A symmetrical load current in all 3 phases of the motor is assumed for flawless operation. When the trigger value, stored in the trigger characteristics, is reached, the motor is switched off and the device switches to fault 8. The fault can be acknowledged via the front Reset button or via the external Reset input.

**IMPORTANT:** The data of the thermal model can be cleared through a Reset or by removing power to the unit. In this case, the user must provide adequate cooling time to the motor.

### Phase Failure Detection

To make sure the motor is not asymmetrically loaded a check takes place during the motor start to determine if phases L1, L2 and L3 are present. If one or several phases are absent then the device switches to fault 4. The fault can be acknowledged via the Reset button or via the external Reset input.

### Mains Isolating Relay (only for model DRMS48D93)

In the off state or when a fault condition is detected the motor terminals are isolated from the mains voltage by a 4-pole forcibly guided contact relay. The contact opening is min. 0.5 mm.

**IMPORTANT:** Do not remove the 24 VDC auxiliary supply voltage while the output is under load. Failure to do so can cause a permanent damage to the mains isolating Relay.

### Signalling Output Relay

Contact 11/14 is closed if no fault is present on the device.

### Reset Function

There are 2 options available to acknowledge a fault condition:

#### Front Reset button:

Acknowledgement is done by momentarily pressing the Reset button at the front of the device. If the button is still pressed after 2 seconds the device resumes the fault state.

#### Remote Reset input:

Remote acknowledgement can be accomplished by connecting an external switch (Normally Open) between terminals MAN and RES. Acknowledgement is triggered as soon as this external contact closes. If the contact is still actuated after 2 seconds the device resumes the fault state since a defect in the acknowledgement circuit cannot be ruled out.



## DIMENSIONS

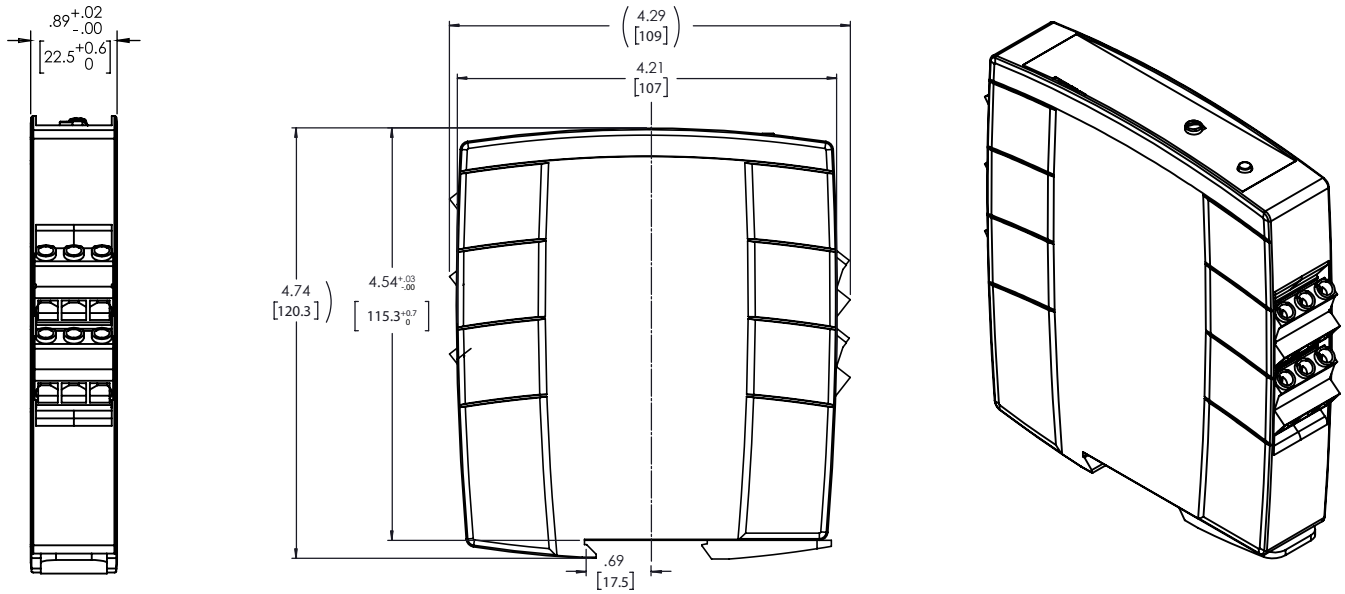
± 0.02 in / 0.5 mm.

All dimensions are in: in [mm]

## DRMS48D91



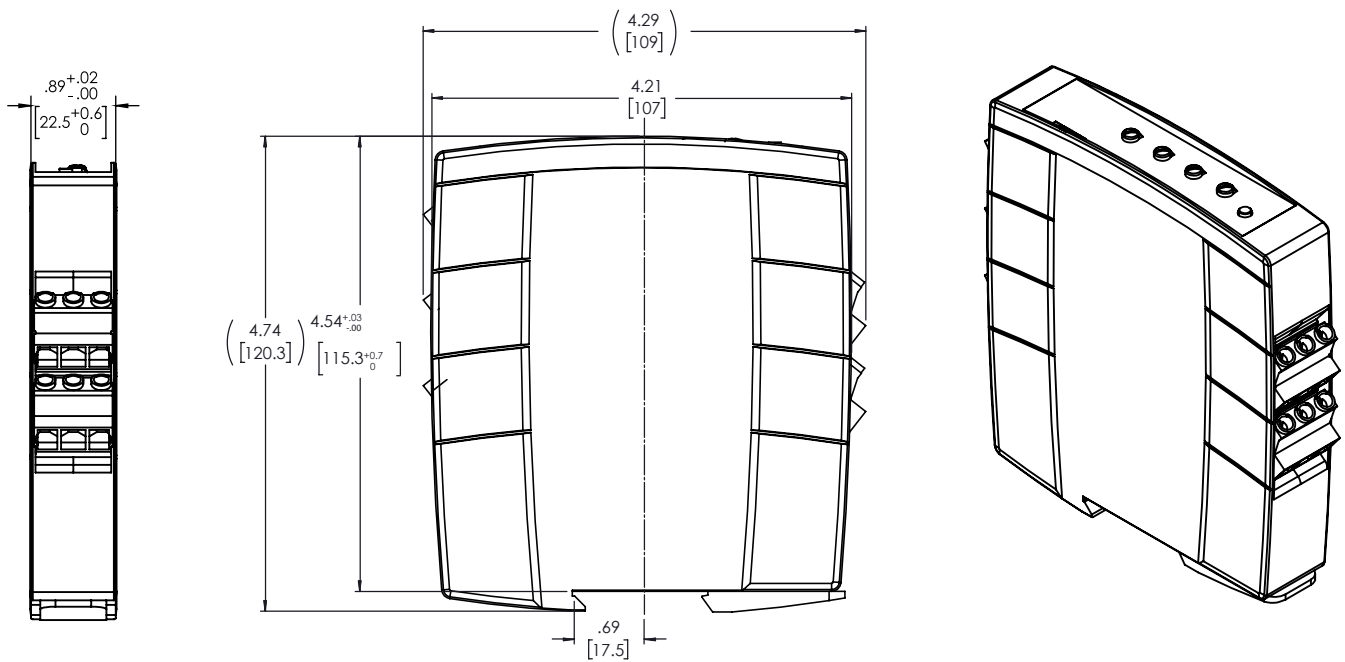
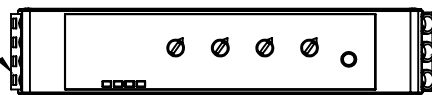




**DRMS48D92, DRMS48D93**

INPUT TERMINAL SLOT SCREW  
(12 PLACES)

OUTPUT TERMINAL SLOT SCREW  
(6 PLACES)





## ORDERING OPTIONS

Example : DRMS48D91

<b>Series</b>	<b>DRMS</b>	<b>48</b>	<b>D</b>	<b>9</b>	<b>1</b>
<b>DRMS</b>					
<b>Operating Voltage</b>					
<b>48: 200-480 VAC</b>					
<b>Control Voltage</b>					
<b>D: 10-30 VDC</b>					
<b>Load Current per Phase</b>					
<b>9: 9 Amps</b>					
<b>Function</b>					
<b>1:</b> Reversing Contactor with Overload Protection <b>2:</b> Reversing Contactor with Soft Start, Soft Stop and Overload Protection <b>3:</b> Reversing Contactor with Soft Start, Soft Stop, Overload Protection and Mains Isolating Relay					



## AGENCY APPROVALS & CERTIFICATIONS

Tested and Certified According To



E116949

UL 508 and C22.2 No.14-13

### With restrictions at motor switching power:

- ANSI/UL 60947-1, 3rd Edition (Low-Voltage Switchgear and Controlgear Part1: General rules)
- ANSI/UL 60947-4-2, 1st Edition (Low-Voltage Switchgear and Controlgear Part 4-2: Contactors and Motor-Starters - AC Semiconductor Motor Controllers and Starters)
- CAN/CSA-C22.2 No. 60947-1-07, 1st Edition (Low-Voltage Switchgear and Controlgear - Part1: General rules)
- CSA-C22.2 No. 60947-4-2-14, 1st Edition (Low-Voltage Switchgear and Controlgear - Part 4-2: Contactors and Motor-Starters - AC Semiconductor Motor Controllers and Starters)

<b>DRMS Motor Circuit Ratings</b>		
<b>Per UL508, CSA C22.2 No. 14-13</b>		
<b>Network Voltage</b>	<b>Ambient Temperature</b>	<b>FLA / LRA</b>
200-480VAC, 3-phase, 50/60Hz	40°C	7.6 / 45.6
	50°C	4.8 / 28.8
	60°C	2.1 / 12.6
<b>Per UL 60947-4-2, CSA 60947-4-2</b>		
200-300VAC, 3-phase, 50/60Hz	40°C	7.6 / 45.6
	50°C	4.8 / 28.8
	60°C	2.1 / 12.6
301-480VAC, 3-phase, 50/60Hz	60°C	2.1 / 12.6

