

## ALS71A561DE550

Aliases (A490FH561M550A)

ALS71, Aluminum Electrolytic, 560 uF, 20%, 550 VDC, -40/+85°C

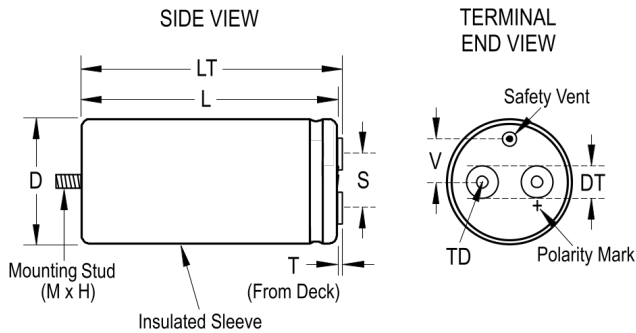

Click [here](#) for the 3D model.

### Dimensions

D	36mm +/-1mm
L	82mm +/-2mm
T	7.1mm +/-0.5mm
S	12.8mm +/-0.5mm
DT	8mm +/-0.5mm
LT	87.5mm +/-1mm
TD	10mm MIN
V	8mm NOM

### Packaging Specifications

Sleeving	Yes
Packaging	Tray

### General Information

Series	ALS71
Dielectric	Aluminum Electrolytic
Description	Screw Terminal, Aluminum Electrolytic
RoHS	Yes
Mounting	Stud
AEC-Q200	No
Halogen Free	Yes
Component Weight	115 g
Notes	Dimensions D And L Include Sleeving. MS (MxH) = M8x12. Mounting Clamp (Sold Separately): V3/H2/2736
Shelf Life	156 Weeks

### Specifications

Capacitance	560 uF
Capacitance Tolerance	20%
Voltage DC	550 VDC, 605 VDC (Surge)
Temperature Range	-40/+85°C
Rated Temperature	85°C
Life	11000 Hrs (Rated Voltage And Ripple Current At 85C), 22000 Hrs (Rated Voltage At 85C)
Resistance	791 mOhms (100Hz 20C), 689 mOhms (10kHz 20C)
Ripple Current	3.5 Amps (100Hz 85C), 6 Amps (10kHz 85C)
Leakage Current	1848 uA

Statements of suitability for certain applications are based on our knowledge of typical operating conditions for such applications, but are not intended to constitute - and we specifically disclaim - any warranty concerning suitability for a specific customer application or use. This information is intended for use only by customers who have the requisite experience and capability to determine the correct products for their application. Any technical advice inferred from this information or otherwise provided by us with reference to the use of our products is given gratis, and we assume no obligation or liability for the advice given or results obtained.