

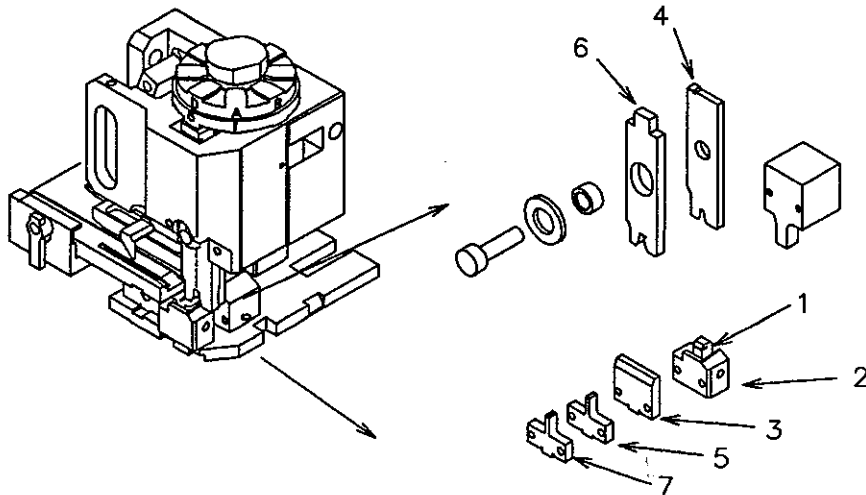

APPLICATOR No. 69037-1039
 PRODUCT No. 90422-0109



<u>ITEM</u>	<u>PART NUMBER</u>	<u>DESCRIPTION</u>
1	69037-0129	REAR SHEAR PUNCH
2	69037-0095	REAR SHEAR DIE
3	69037-0214	REAR SHEAR PLATE
4	69039-1521	CONDUCTOR PUNCH
5	69039-3518	CONDUCTOR ANVIL
6	69039-2528	INSULATION PUNCH
7	69039-4521	INSULATION ANVIL
8	69037-2039	TOOL KIT (ITEMS 4 - 7)

CRIMP SPECIFICATION: (SEE ALSO PRODUCT SPEC. CS.90422)

<u>WIRE mm2 (AWG)</u>	<u>CRIMP HEIGHT (COND)</u>
0.75	1.60/1.65mm (.063" / .065")
1.25	1.78/1.85mm (.070" / .073")

WIRE STRIP LENGTH: - 4.25 / 4.75mm (0.167" / 0.187")