

ITEM #	PART #	QTY	DESCRIPTION
1	MAJ-60-07B	1	INSERT ASSY, RECEPTACLE
2	MAJ-60-05	1	NUT, (PM-MA)
3	MAJ-60-16	1	O-RING, PANEL MOUNT

B MAJ-60-00B-CP

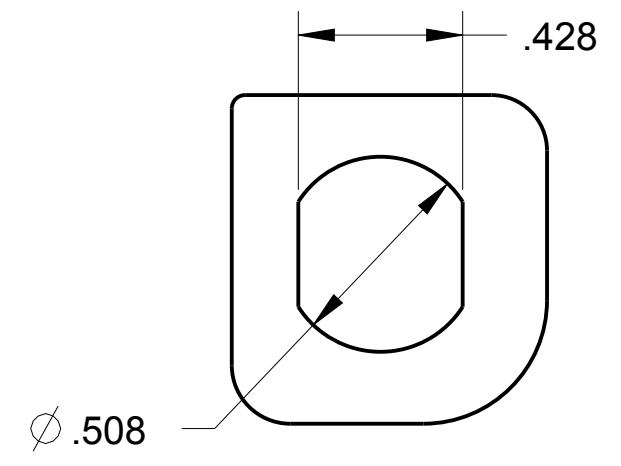

RECOMMENDED
PANEL CUTOUT

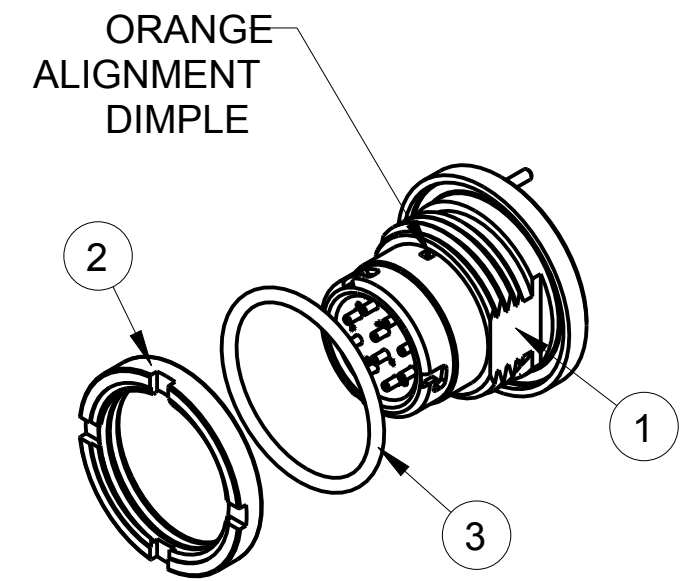
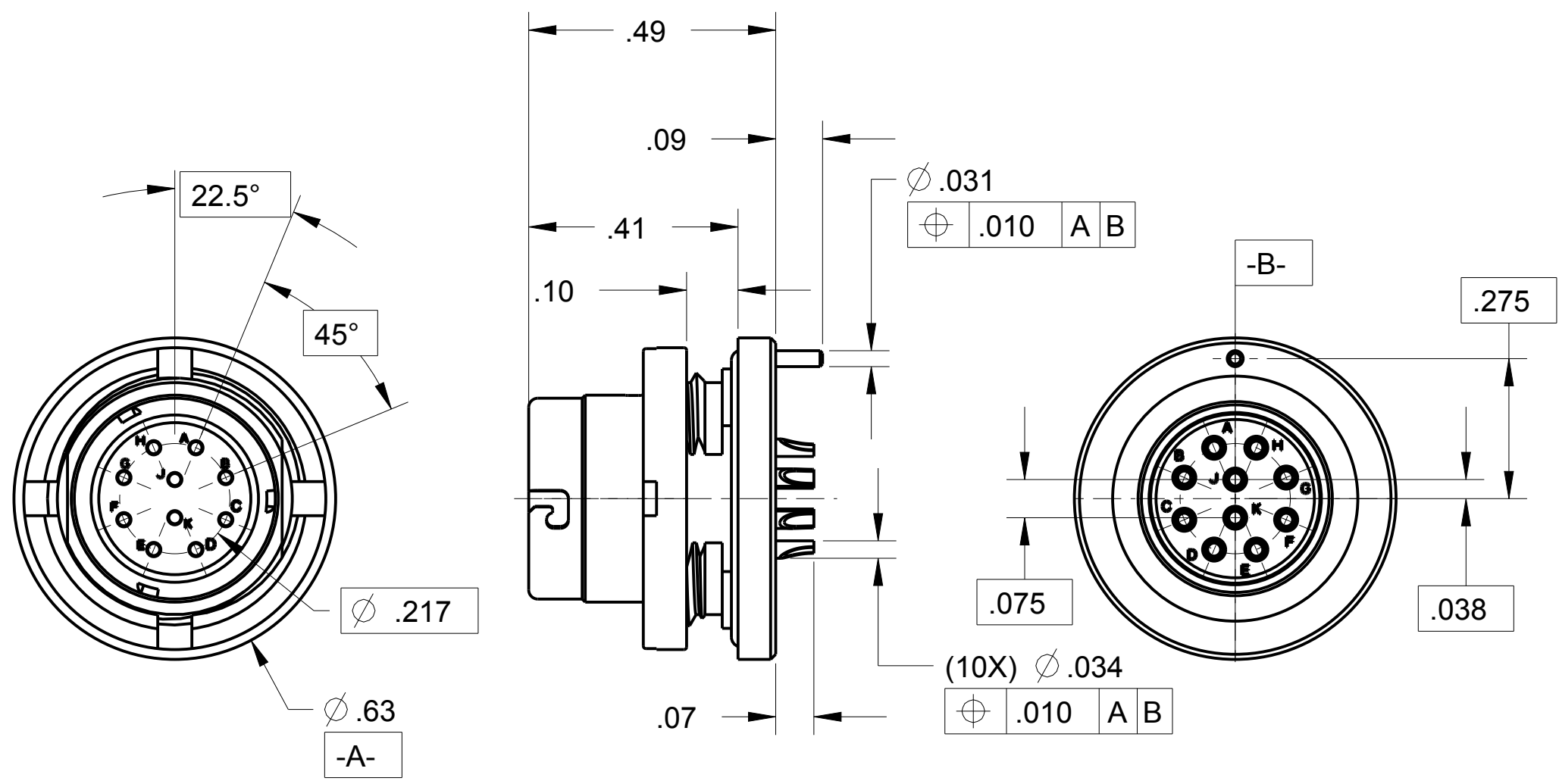

THIS DOCUMENT CONTAINS PROPRIETARY INFORMATION OF NEXUS, INCORPORATED AND SUCH INFORMATION MAY NOT BE DISCLOSED TO OTHERS FOR ANY PURPOSE OR USED FOR ANY PURPOSE WITHOUT THE WRITTEN CONSENT OF NEXUS.

LET.	REVISION	CN #	DATE	CHK.
A	NEW RELEASE	185	10/14/2013	HR

DWN. BY	HR	DATE	10/14/13	MATERIAL
CHECKED BY		DATE		FINISH
APPR. BY		DATE		WEIGHT —
UNLESS OTHERWISE SPECIFIED: DIMENSIONS ARE IN INCHES &/OR (mm)				SCALE = 2.00 :1
TOLERANCES:				TITLE 10 COND RECEPTACLE PM W/GROUND PIN
DECIMAL: .XX[X.X] .XXX[X.XX] ± .0X[0.X] ± .00X[0.0X]				
FRACTION: X/X ± X/XX				DO NOT SCALE DWG.
ANGLES: .X ± .X°				SHEET 1 OF 1
			SIZE	NEXUS STAMFORD, CONN
			DWG. NO.	
			B	MAJ-60-00B-CP