

THIS DRAWING IS UNPUBLISHED.

RELEASED FOR PUBLICATION

© COPYRIGHT - TE Connectivity Ltd.

ALL RIGHTS RESERVED.

REVISIONS

P	LTR	DESCRIPTION	DATE	DWN	APVD
	B	REVISED PER ECR-19-004770	10APR2019	SR	DD

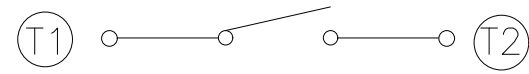

CIRCUIT DIAGRAM

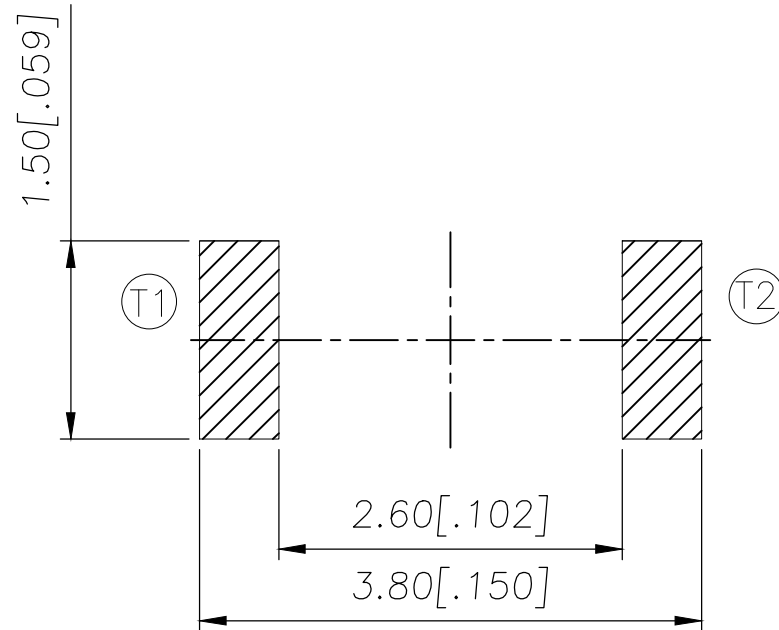
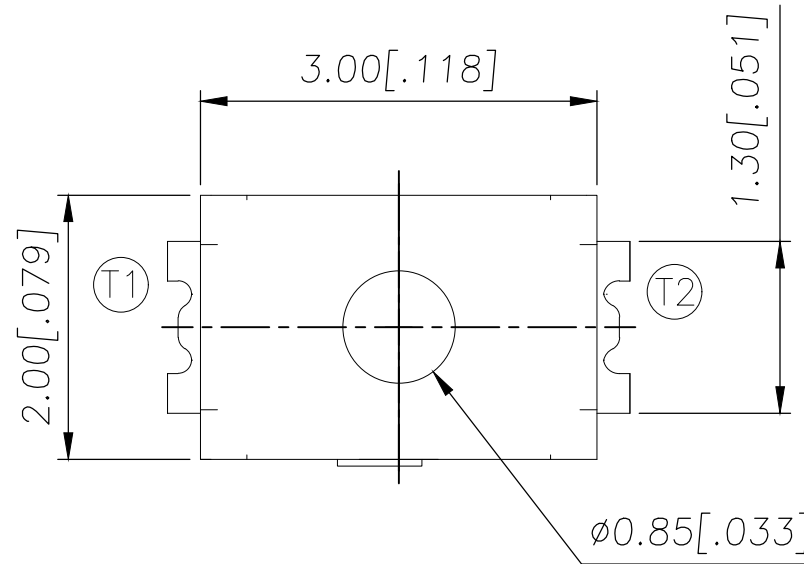

PCB LAYOUT

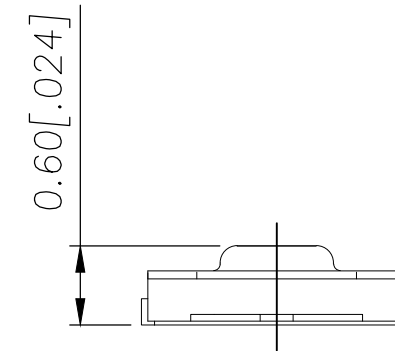
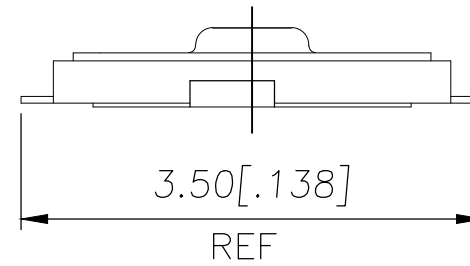

240±50	USLPT3020DT6TR	2337230-3
180±50	USLPT3020DT3TR	2337230-2
160±50	USLPT3020DT2TR	2337230-1
ACTUATION FORCE (gf)	SMART PART NUMBER	PART NUMBER

THIS DRAWING IS A CONTROLLED DOCUMENT.

DWN GANESH C M 04JUL2018

CHK ALEXANDER SHARPE 04JUL2018

APVD ALEXANDER SHARPE 04JUL2018

PRODUCT SPEC

APPLICATION SPEC

WEIGHT

CUSTOMER DRAWING

DIMENSIONS:  
mm [INCHES]

TOLERANCES UNLESS OTHERWISE SPECIFIED:

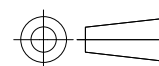

0 PLC	± -
1 PLC	± -
2 PLC	± 0.1 [.004]
3 PLC	± -
4 PLC	± -
ANGLES	± -

MATERIAL

FINISH



TE Connectivity Ltd.

SWITCH, TACTILE, LOW-PROFILE, ULTRA-MINI,  
3.0 x 2.0 x 0.6, TAB

SIZE	CAGE CODE	DRAWING NO	RESTRICTED TO
A3	00779	C-2337230	-

SCALE	SHEET	REV
NTS	1 of 3	B

THIS DRAWING IS UNPUBLISHED.

RELEASED FOR PUBLICATION

REVISIONS

© COPYRIGHT - TE Connectivity Ltd.

ALL RIGHTS RESERVED.

P	LTR	DESCRIPTION	DATE	DWN	APVD
-	-	SEE SHEET 1	-	-	-

NOTES:

1. MATERIALS:

TERMINAL: COPPER ALLOY, SILVER FINISH  
 BASE: THERMOPLASTIC, BLACK  
 TAPE: POLYIMIDE  
 ACTUATOR: POLYIMIDE  
 CONTACT: STAINLESS STEEL, SILVER FINISH

2. COMPLIANCE:

ALL MATERIALS AND FINISHES SHALL COMPLY WITH  
 EU DIRECTIVE 2002/95/EC OF 27JAN2003(RoHS)

3. SPECIFICATIONS:

RATING: 10  $\mu$ A, 1V DC MINIMUM TO 50 mA, 12V DC MAXIMUM  
 CONTACT RESISTANCE: 500m $\Omega$  MAXIMUM (INITIAL)  
 INSULATION RESISTANCE: 100M $\Omega$  MINIMUM (INITIAL)  
 DIELECTRIC STRENGTH: 100V AC, 1 MINUTE  
 OPERATING LIFE: 300,000 CYCLES WITH LOAD  
 TRAVEL: 0.13 $\pm$ 0.05 [.005 $\pm$ .002]  
 ACTUATION FORCE: 2337230-1 = 160 $\pm$ 50gf  
                           2337230-2 = 180 $\pm$ 50gf  
                           2337230-3 = 240 $\pm$ 50gf  
 OPERATING TEMPERATURE: -40° TO 85°C  
 STORAGE TEMPERATURE: -40° TO 85°C

4. SOLDER CONDITIONS:

SMT:

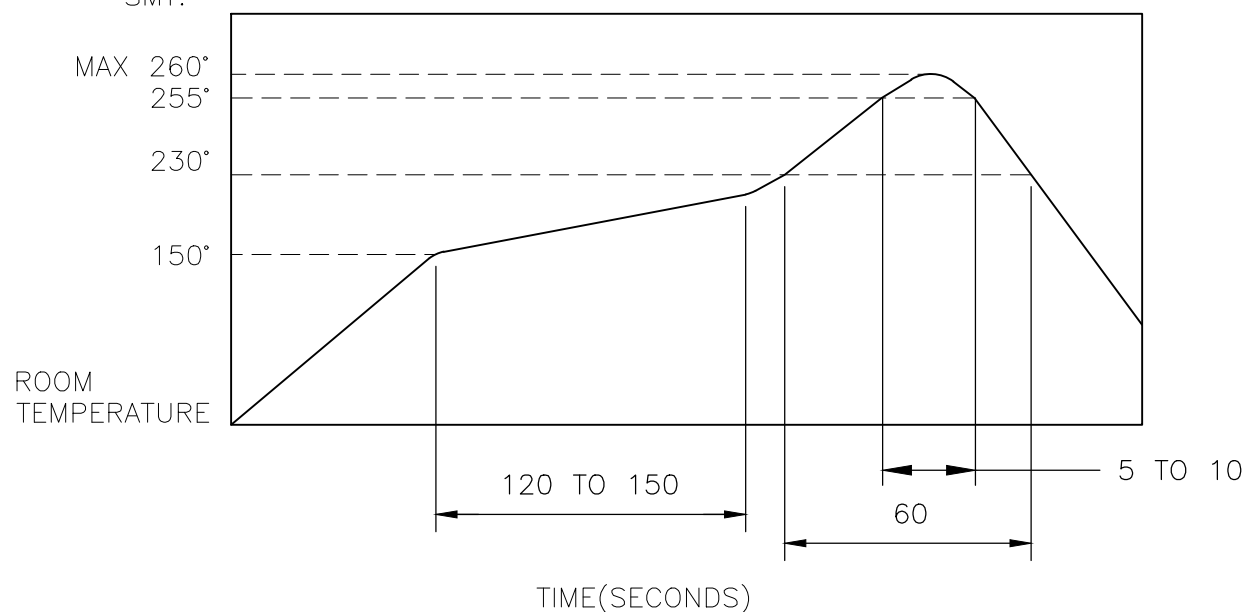

THE CONDITION NOTED ABOVE IS THE TEMPERATURE OF THE COPPER FOIL ON THE SURFACE OF THE PCB. THERE ARE CASES WHERE THE TEMPERATURE OF THE BOARD GREATLY DIFFERS FROM THE SURFACE OF THE SWITCH. DO NOT ALLOW THE SURFACE TEMPERATURE OF THE SWITCH TO EXCEED 260°C.

MANUAL SOLDERING:

SOLDERING TEMPERATURE	350°C MAXIMUM
CONTINUOUS SOLDERING TIME	5 SECONDS MAXIMUM

HANDLING PRECAUTIONS:

- CARE SHOULD BE EXERCISED SO THAT FLUX FROM THE TOP SURFACE OF THE PRINTED CIRCUIT BOARD DOES NOT ADHERE TO THE SWITCH.
- DO NOT WASH THE SWITCH

5. OPERATING PRECAUTIONS:

- DO NOT ACTUATE THE SWITCH WITH EXCESSIVE FORCE
- DISCONTINUE FORCE AFTER THE SWITCH HAS BEEN ACTUATED SO AS TO AVOID DEFORMATION OF THE COMPONENTS OF THE SWITCH. DEFORMATION OF THE COMPONENTS MAY CAUSE THE SWITCH TO MALFUNCTION.
- ALIGN THE PLUNGER WITH THE SWITCH TO INSURE PROPER OPERATION

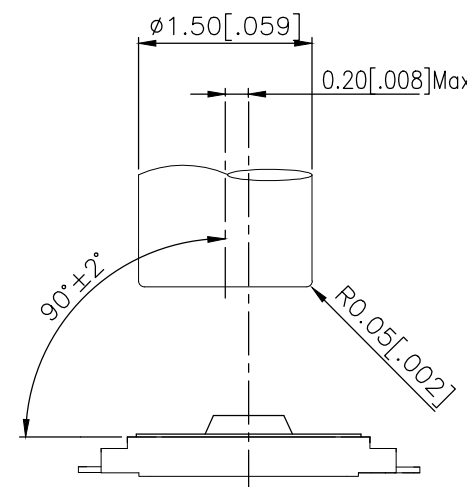

RECOMMENDED OPERATING CONDITIONS

THIS DRAWING IS A CONTROLLED DOCUMENT.		DWN GANESH C M 04JUL2018	TE Connectivity Ltd.														
DIMENSIONS: mm [INCHES]		CHK ALEXANDER SHARPE 04JUL2018															
TOLERANCES UNLESS OTHERWISE SPECIFIED:		APVD ALEXANDER SHARPE 04JUL2018	NAME SWITCH, TACTILE, LOW-PROFILE, ULTRA-MINI, 3.0 x 2.0 x 0.6, TAB														
<table border="1"> <tr><td>0 PLC</td><td>± -</td></tr> <tr><td>1 PLC</td><td>± -</td></tr> <tr><td>2 PLC</td><td>± 0.1 [.004]</td></tr> <tr><td>3 PLC</td><td>± -</td></tr> <tr><td>4 PLC</td><td>± -</td></tr> <tr><td>ANGLES</td><td>± -</td></tr> </table>		0 PLC	± -	1 PLC	± -	2 PLC	± 0.1 [.004]	3 PLC	± -	4 PLC	± -	ANGLES	± -	PRODUCT SPEC -	RESTRICTED TO -		
0 PLC	± -																
1 PLC	± -																
2 PLC	± 0.1 [.004]																
3 PLC	± -																
4 PLC	± -																
ANGLES	± -																
MATERIAL -		APPLICATION SPEC -	SIZE A3	CAGE CODE 00779	DRAWING NO C-2337230												
FINISH -		WEIGHT -	CUSTOMER DRAWING		SCALE NTS SHEET 2 OF 3 REV B												

THIS DRAWING IS UNPUBLISHED. RELEASED FOR PUBLICATION  
 © COPYRIGHT - TE Connectivity Ltd. ALL RIGHTS RESERVED.

REVISIONS					
P	LTR	DESCRIPTION	DATE	DWN	APVD
-	-	SEE SHEET 1	-	-	-

THE DIMENSIONS OF CARRIER TAPE AND REEL

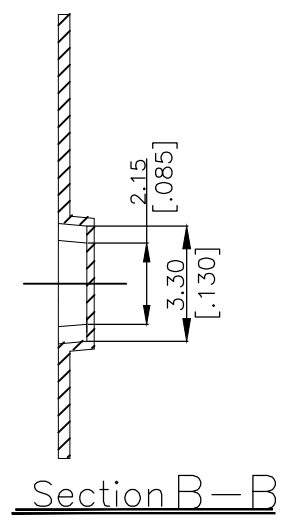
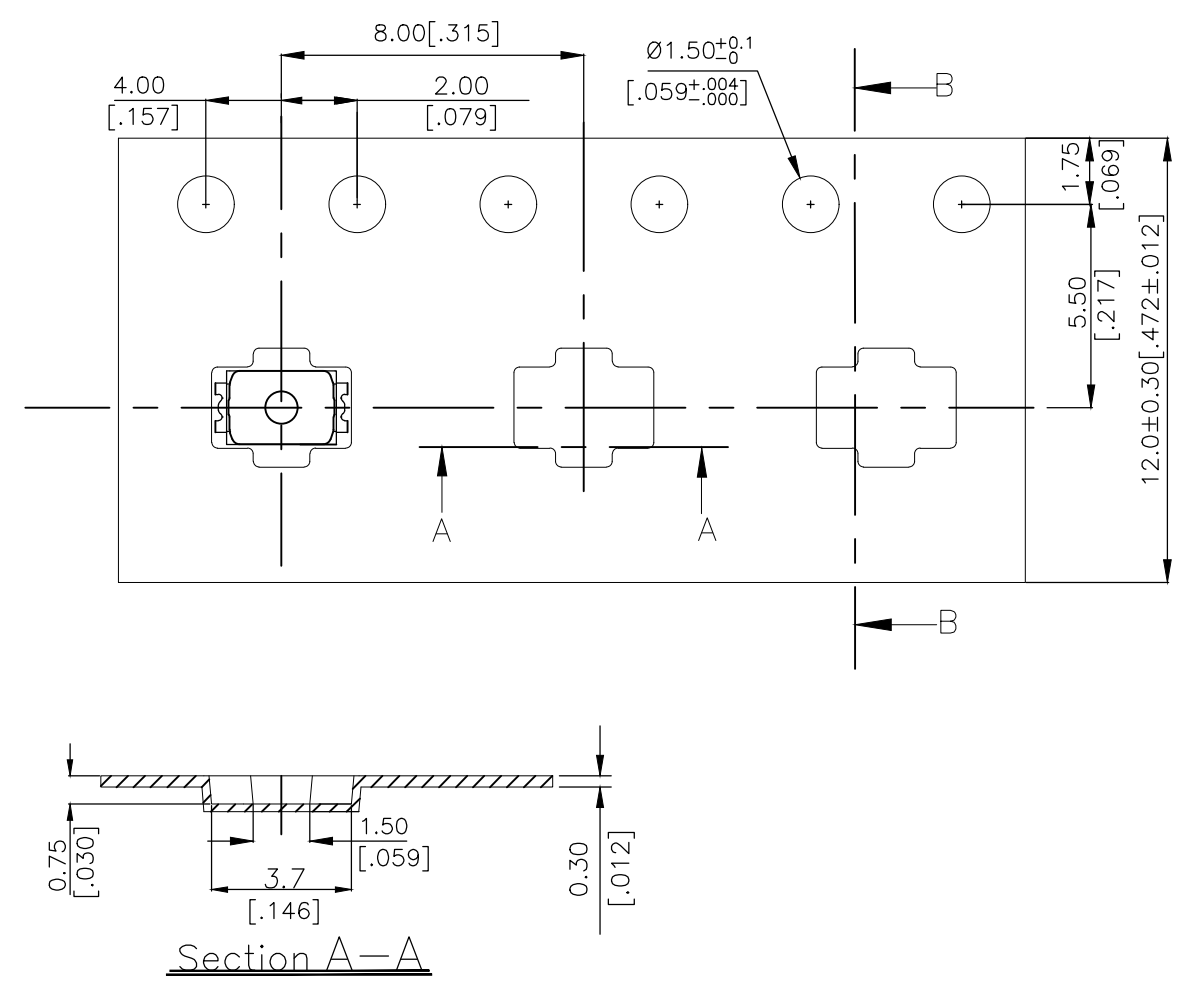

ORIENTATION OF PILOT HOLES

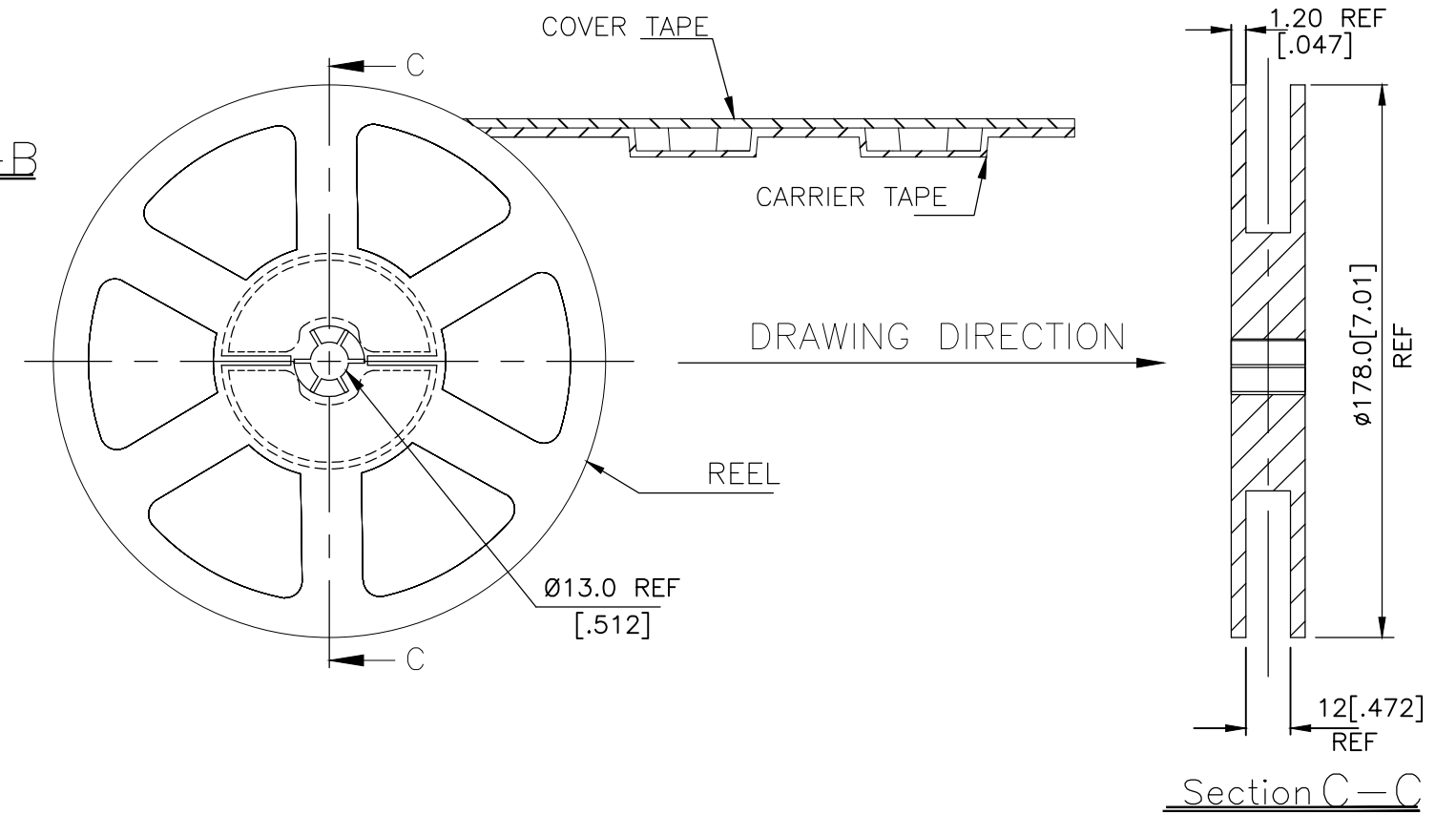
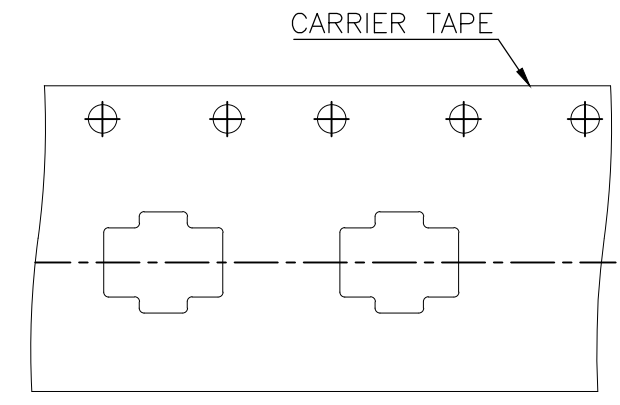

6. PACKAGING:
1. THE TAPE AND REEL ARE SHOWN FOR CUSTOMER APPLICATION REFERENCE. PACKAGING NOTES 3 AND 4 ARE REQUIRED BUT NOT ILLUSTRATED.
  2. 2,500 SWITCHES PER REEL.
  3. THE REEL, DESICCANT POUCH AND HUMIDITY CARD ARE SEALED IN A MOISTURE BARRIER BAG PER THE CURRENT REVISION OF IPC/JEDEC J-STD-033, MSL 2A REQUIREMENTS.
  4. THE MOISTURE BARRIER BAG IS LABELED PER THE CURRENT REVISION OF IPC/JEDEC J-STD-033, MSL 2A REQUIREMENTS.

THIS DRAWING IS A CONTROLLED DOCUMENT.		DWN GANESH C M 04JUL2018	TE Connectivity Ltd.														
DIMENSIONS: mm [INCHES]		CHK ALEXANDER SHARPE 04JUL2018				NAME SWITCH, TACTILE, LOW-PROFILE, ULTRA-MINI, 3.0 x 2.0 x 0.6, TAB											
TOLERANCES UNLESS OTHERWISE SPECIFIED:		APVD ALEXANDER SHARPE 04JUL2018	PRODUCT SPEC														
<table border="1"> <tr><td>0 PLC</td><td>± -</td></tr> <tr><td>1 PLC</td><td>± -</td></tr> <tr><td>2 PLC</td><td>± 0.1 [.004]</td></tr> <tr><td>3 PLC</td><td>± -</td></tr> <tr><td>4 PLC</td><td>± -</td></tr> <tr><td>ANGLES</td><td>± -</td></tr> </table>		0 PLC	± -	1 PLC	± -	2 PLC	± 0.1 [.004]	3 PLC	± -	4 PLC	± -	ANGLES	± -	APPLICATION SPEC	SIZE CAGE CODE DRAWING NO RESTRICTED TO		
0 PLC	± -																
1 PLC	± -																
2 PLC	± 0.1 [.004]																
3 PLC	± -																
4 PLC	± -																
ANGLES	± -																
MATERIAL		WEIGHT	A3 00779 C-2337230														
		CUSTOMER DRAWING	SCALE NTS	SHEET 3 OF 3	REV B												