

- **Low Insertion Loss**
- **3.8 X 3.8 X 1.0 mm Surface Mount Case**
- **Single-Ended Input/Output**
- **Complies with Directive 2002/95/EC (RoHS)**

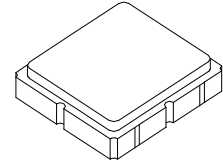

**SF2170D**

**165 MHz  
SAW Filter**



**SM3838-6**

**Absolute Maximum Ratings**

Rating	Value	Units
Maximum Incident Power in Passband	+10	dBm
Maximum DC Voltage Between any 2 Terminals	30	VDC
Storage Temperature Range in Tape and Reel	-40 to +85	°C
Suitable for Lead-free Soldering - Maximum Soldering Profile	260°C for 30 s	

**Electrical Characteristics**

Characteristic	Sym	Notes	Min	Typ	Max	Units
Center Frequency	$f_c$			165		MHz
Source Impedance to Matching Network (single ended)				50		$\Omega$
Load Impedance to Matching Network (single ended)				50		$\Omega$
Passband Width			20	22		MHz
Rejection Referenced to Minimum Insertion Loss:						dB
10 MHz to 110 MHz			35	40		
127 MHz to 149 MHz			10	15		
190 to 210 MHz			30	40		
210 to 450 MHz			40	45		
Maximum Insertion Loss				9	10	dB
Insertion Loss Variation over -40 to 85 °C					1	dB
Amplitude Variation over 20 MHz Passband				1.0	1.5	dB <sub>p-p</sub>
Group Delay Variation over 20 MHz Passband				40	80	ns <sub>p-p</sub>
Absolute Group Delay at $f_c$				0.33		$\mu$ s
Input/Output Return Loss into Matching over 20 MHz BW			6	8		dB
Operating Temperature			-40		+85	°C

Case Style	SM3838-6 3.8 x 3.8 mm Nominal Footprint		
Lid Symbolization (Y=year, WW=week, S=shift) dot=pin 1 indicator	865, YWWS		
Standard Reel Quantity	Reel Size 7 Inch	1000 Pieces/Reel	
	Reel Size 13 Inch	3000 Pieces/Reel	



**CAUTION: Electrostatic Sensitive Device. Observe precautions for handling.**

**NOTES:**

1. The design, manufacturing process, and specifications of this device are subject to change.
2. US or International patents may apply.

# Broadband Filter Response and Return Loss (through matching network)

17 Sep 2008 06:49:06

CH1 LOG 5 dB/ REF 0 dB  
S11 3 : 5.2056 dB 20 .000 000 MHz

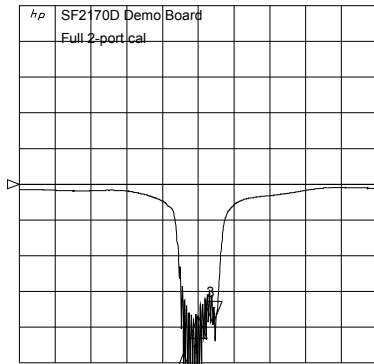

CH1 Markers  
Δ REF=2  
mean : -20 .948 dB  
s. dev : 5.2747 dB  
p-p : 29.591 dB

CH3 LOG 5 dB/ REF 0 dB  
S22 3 : -3.5658 dB 20 .000 000 MHz

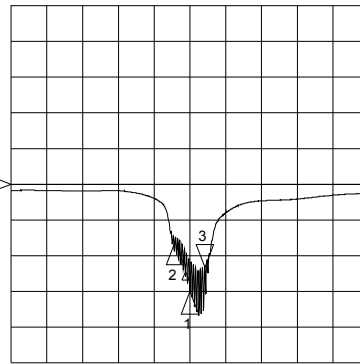

CH3 Markers  
Δ REF=2  
mean : -12 .005 dB  
s. dev : 2.7750 dB  
p-p : 11.003 dB

CENTR 165 .000 MHz SPAN 240 .000 MHz

CENTR 165 .000 MHz SPAN 240 .000 MHz

CH2 S21 LOG 10 dB/ REF -55 dB 1 : -9.8909 dB 158 .700 000 MHz

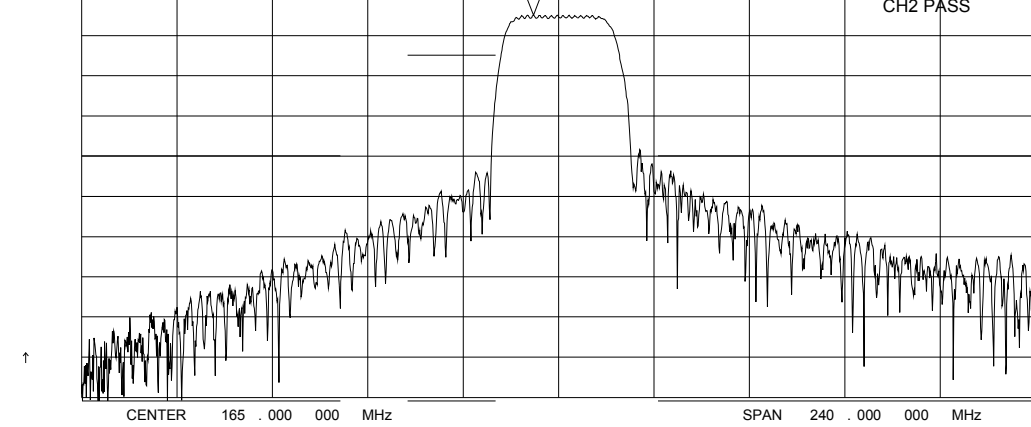

Max

# Passband Amplitude and Impedance Detail

17 Sep 2008 14:04:20

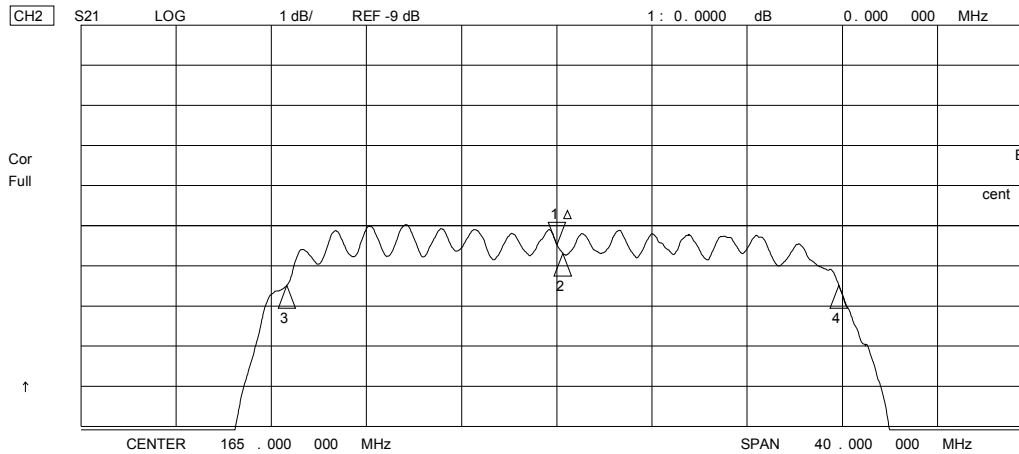
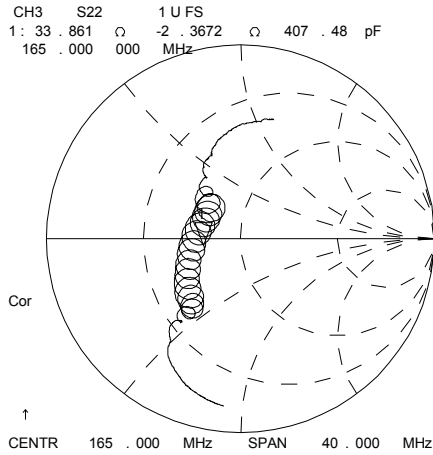
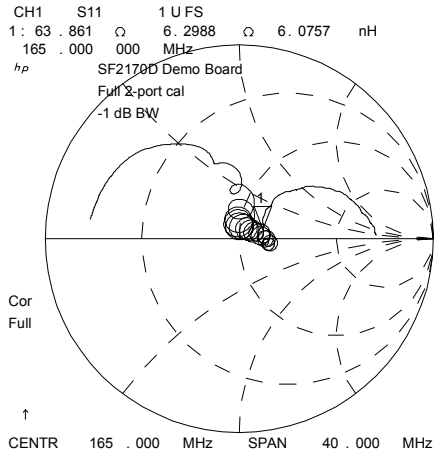

CH2 Markers  
 Δ REF=1  
 BW: 23 . 196777 MHz  
 cent : 165 . 256979 MHz  
 Q: 7 . 1241  
 1 loss : -9 . 4834 dB

# Passband Group Delay and Amplitude Ripple

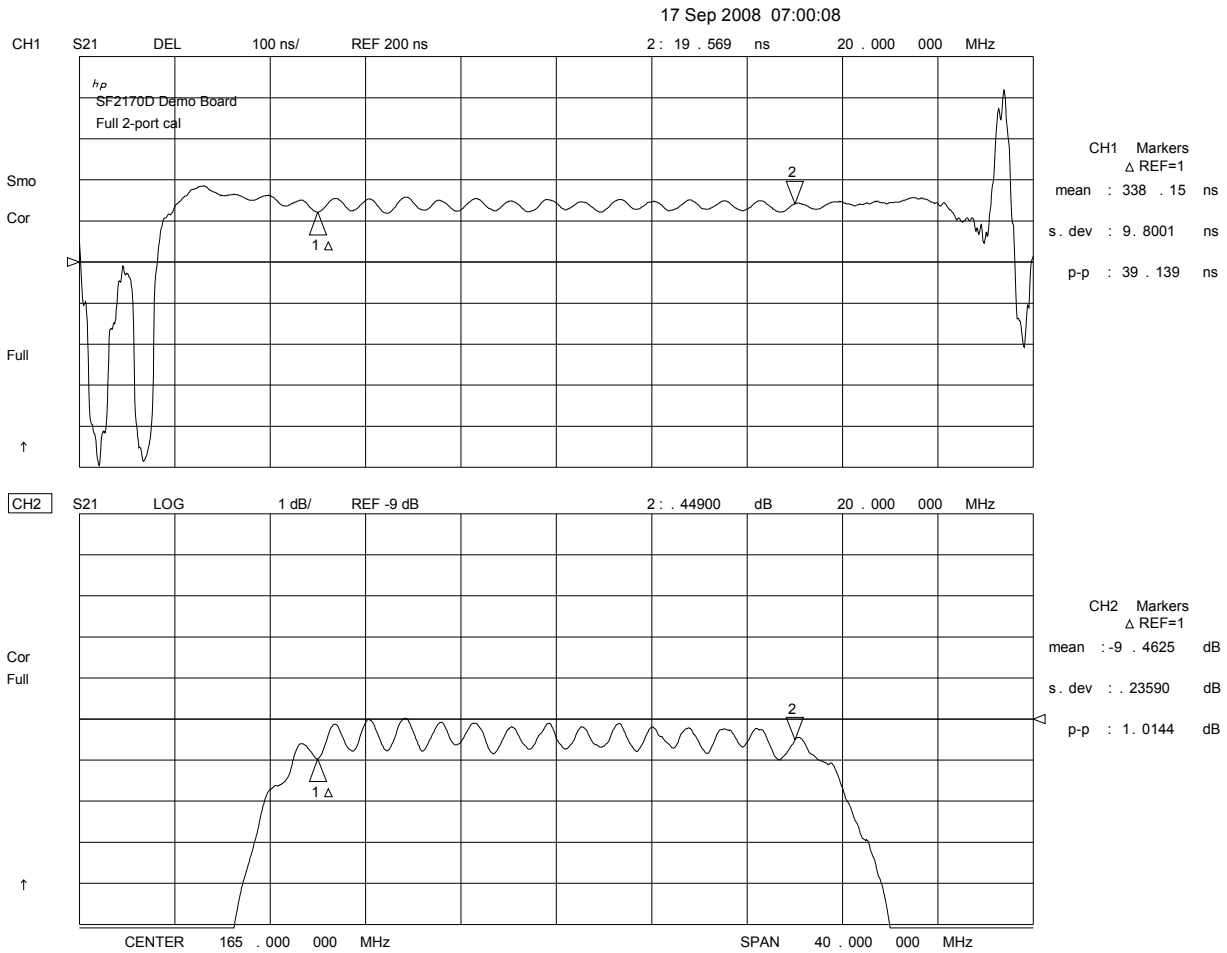

## SF2170D Demo Circuit

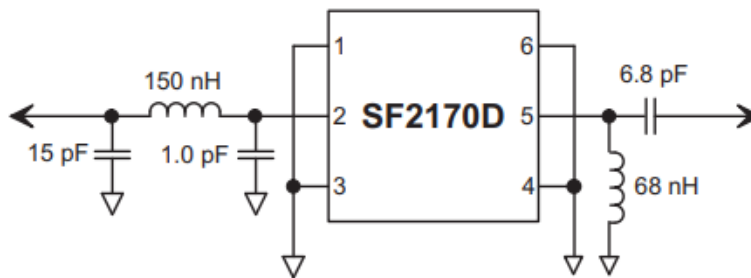

## Tape and Reel Specifications

Tape and Reel Standard per ANSI/EIA-481

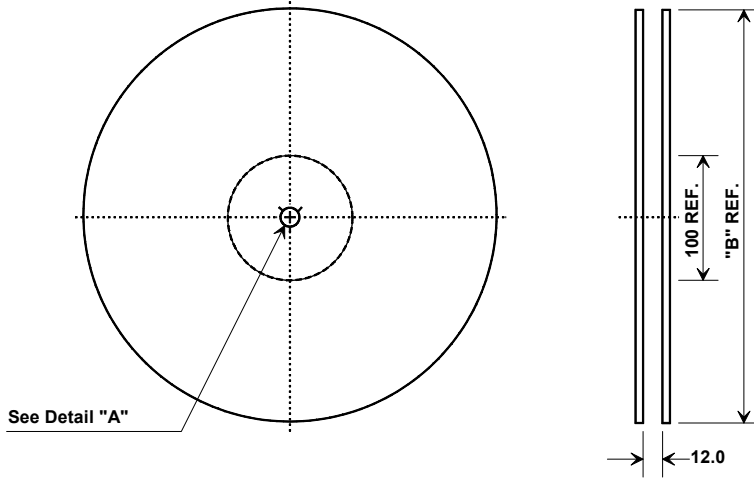

"B"		Quantity Per Reel
Inches	millimeters	
7	178	1000
13	330	3000

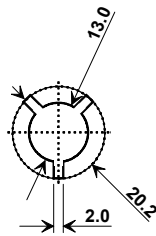

### COMPONENT ORIENTATION and DIMENSIONS

Carrier Tape Dimensions	
<b>Ao</b>	4.25 mm
<b>Bo</b>	4.25 mm
<b>Ko</b>	1.30 mm
<b>Pitch</b>	8.0 mm
<b>W</b>	12.0 mm

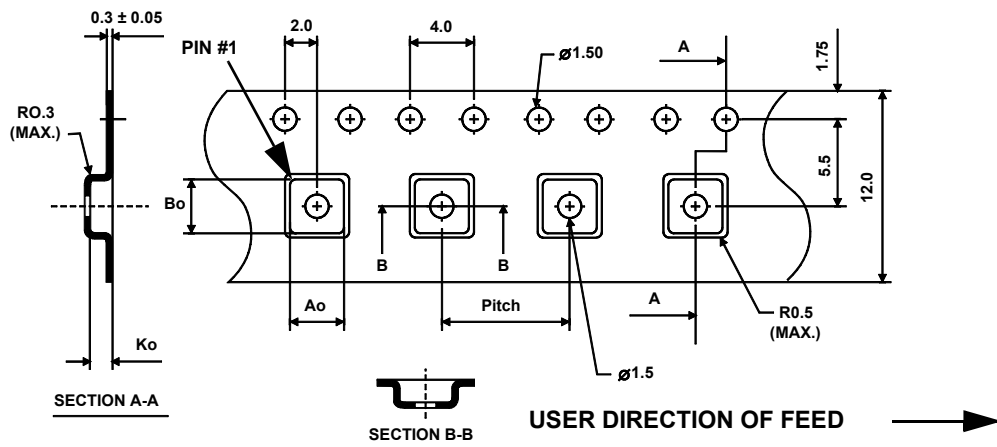

# SM3838-6 Case

## 6-Terminal Ceramic Surface-Mount Case

### 3.8 X 3.8 mm Nominal Footprint

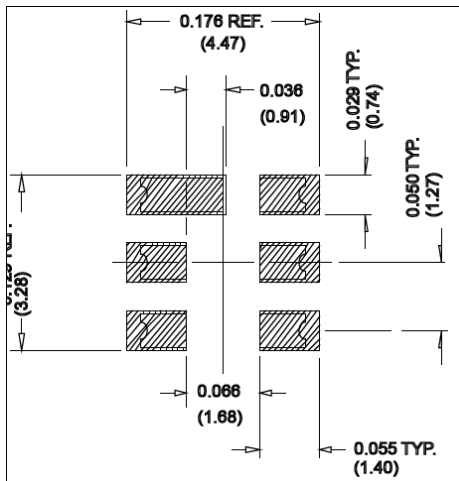
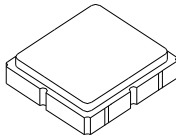

PCB Footprint

Case Dimensions						
Dimension	mm			Inches		
	Min	Nom	Max	Min	Nom	Max
A	3.60	3.80	4.0	0.14	0.15	0.16
B	3.60	3.80	4.0	0.14	0.15	0.16
C	1.30	1.50	1.70	0.05	0.06	0.067
D	0.95	1.10	1.25	0.037	0.043	0.05
E	2.39	2.54	2.69	0.090	0.10	0.110
G	0.90	1.0	1.10	0.035	0.04	0.043
H	1.90	2.0	2.10	0.75	0.08	0.83
I	0.50	0.6	0.70	0.020	0.024	0.028
J	1.70	1.8	1.90	0.067	0.07	0.075

Electrical Connections		
Connection	Terminals	
Port 1	Single-ended Input	2
Port 2	Single-ended Output	5
	Ground	All others

**Single Ended Operation Only**

Dot indicates Pin 1

Materials	
Solder Pad Plating	0.3 to 1.0 $\mu\text{m}$ Gold over 1.27 to 8.89 $\mu\text{m}$ Nickel
Lid Plating	2.0 to 3.0 $\mu\text{m}$ Nickel
Body	$\text{Al}_2\text{O}_3$ Ceramic
Pb Free	

TOP VIEW

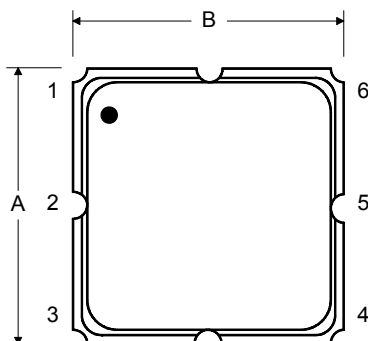

BOTTOM VIEW

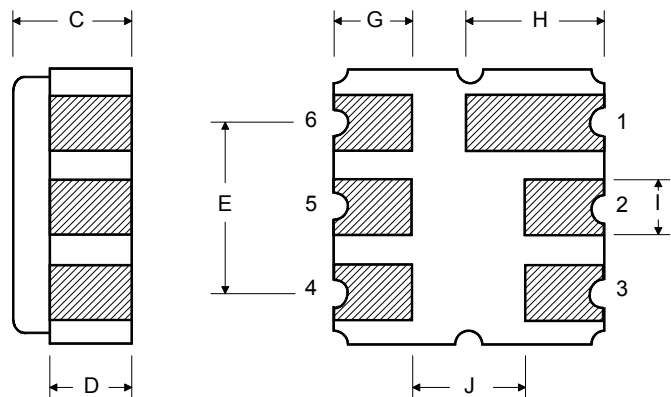

## Recommended Reflow Profile

1. Preheating shall be fixed at 150~180°C for 60~90 seconds.
2. Ascending time to preheating temperature 150°C shall be 30 seconds min.
3. Heating shall be fixed at 220°C for 50~80 seconds and at 260°C +0/-5°C peak (10 seconds).
4. Time: 5 times maximum.

