

MM8118W02LFE Eval Board

MM8118W02 Eval Board is an evaluation board for the purpose of remaining capacity evaluation for Li-ion battery. A current sense resistor and a thermistor is mounted on this board. By using Interface Box and “EvaTool” software for MM8118W02 at the evaluation of Li-ion battery, the user can get Log such as voltage, current and remaining capacity etc., and write the battery parameter and set the other general settings.

Contents

1. Feature	
1.1 Eval Board Information	P.3
1.2 Eval Board Specification	P.3
2. Eval Board Connections	
2.1 Connection example to Eval Board	P.4
2.2 Pin Descriptions	P.5
3. Eval Board Layout	
3.1 Layout and Bill of Materials	P.6
3.2 Schematic	P.7
4. Software	
4.1 EvaTool	P.8
4.2 Ready to use EvaTool	P.8
4.3 Communication to Eval Board	P.9
4.4 EvaTool Basic Operation	P.9
4.5 Check Battery Parameter Data	P.10
4.6 Make Battery Parameter	P.10
4.7 Write Battery Parameter	P.11
4.8 Each Sensors Calibration	P.11
5. NOTES	P.12

1. Feature

- Intelligent Gauge6 (=Remaining capacity estimation algorithm with low power-consumption) installed Eval Board
- Eval Board is able to check and record Remaining capacity easily by the software

1.1 Eval Board Information

Table 1. Supported Battery

Name	Configuration	Battery type	Battery Capacity
MM8118W02 Eval Board	1 Cell	Li-ion	16000mAh or less

1.2 Eval Board Specification

Table 2. Eval Board Specification

Parameter	MIN.	TYP.	MAX.
Input voltage B+ to B- and P+ to P-	2.5V	-	5.5V
Input voltage range of I/O pin (SDA/SCL/ALERT/IO1/IO4/IO5)	-0.3V	-	VDD+0.3V
Charge / Discharge current P+ to P-	0.0A	1.0A	3.0A
Current sense resistor	-	20mΩ	-

2. Eval Board Connections

2.1 Connection example to Eval Board

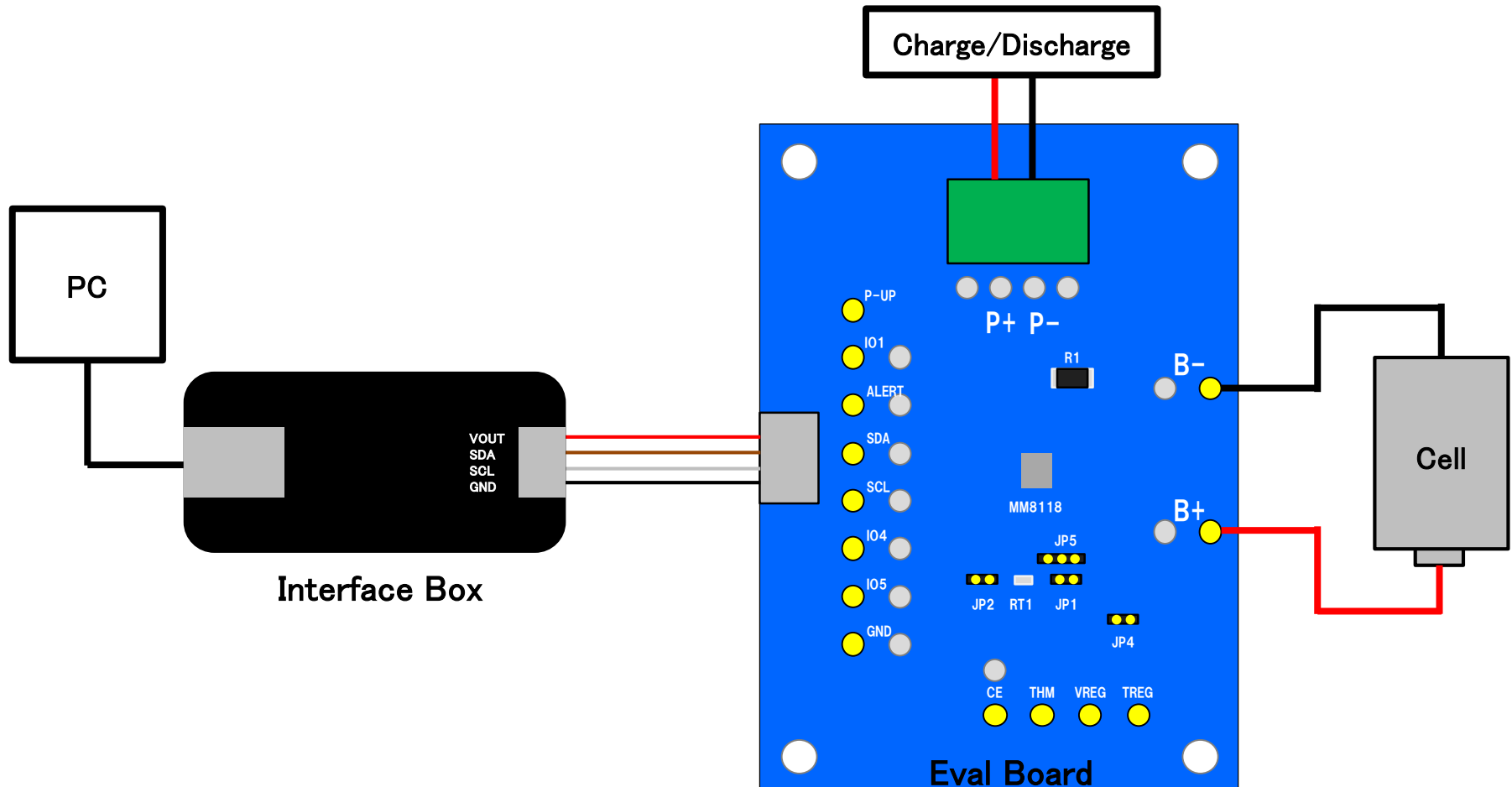

Figure 1. Eval Board Connection

2.2 Pin Descriptions

Table 3. Eval Board Pin

Name	Description
B+	Cell+ terminal
B-	Cell- terminal
P+	Pack+ terminal
P-	Pack- terminal
VREG	Regulator output terminal
TREG	Regulator output terminal for thermistor
THM	Thermistor input terminal
SDA	I2C data input/output terminal
SCL	I2C clock input/output terminal
IO1	General purpose output terminal
IO4	General purpose output terminal
IO5	General purpose output terminal
ALERT	General purpose output terminal
CE	Chip enable terminal ※If you do not use this function, please set JP5 to Pull-up side.
P-UP	External power input terminal for pull-up ※If you use External power for Pull-up to general purpose terminal, please mount 1K Ω resistor on R13 (ALERT), R14 (IO1), R18 (IO4) and R19 (IO5)..

Please refer to MM8118W02LFE specification for each terminal ratings.

3. Eval Board Layout

3.1 Layout and Bill of Materials

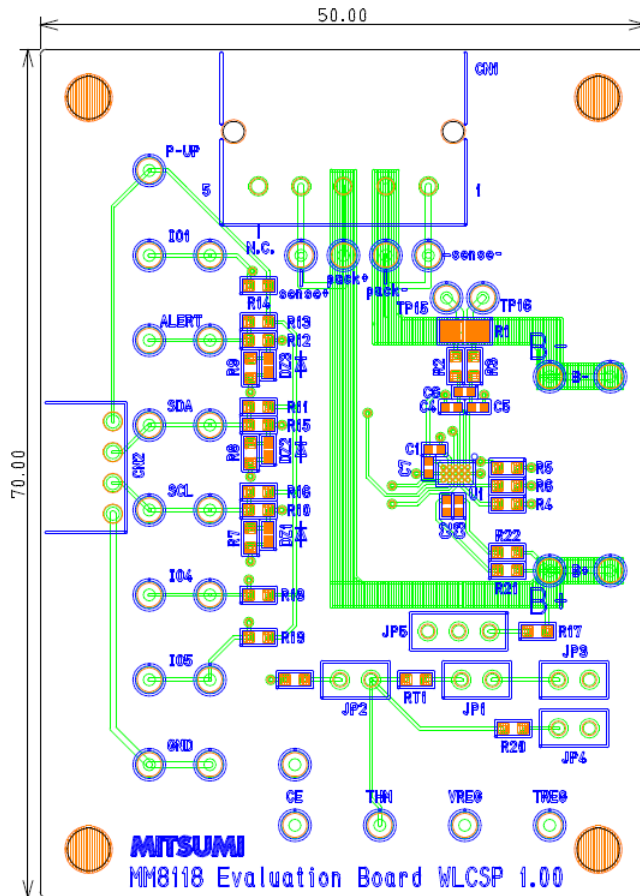

Figure 2. Eval Board Layout

Table 4. Bill of Materials

Symbol	Value
C1	0.47 μ F
C2	1.0 μ F
C3	0.1 μ F
R1	20m Ω
R2,R3	0 Ω
R4,R5,R6 R10,R12,R15,R22	100 Ω
R17	10k Ω
R20	100k Ω
R21	10 Ω
RT1	10k Ω
RT2	100k Ω
DZ1,DZ2,DZ3	Breakdown voltage Min. 5.8V

3. Eval Board Layout

3.2 Eval Board Schematic

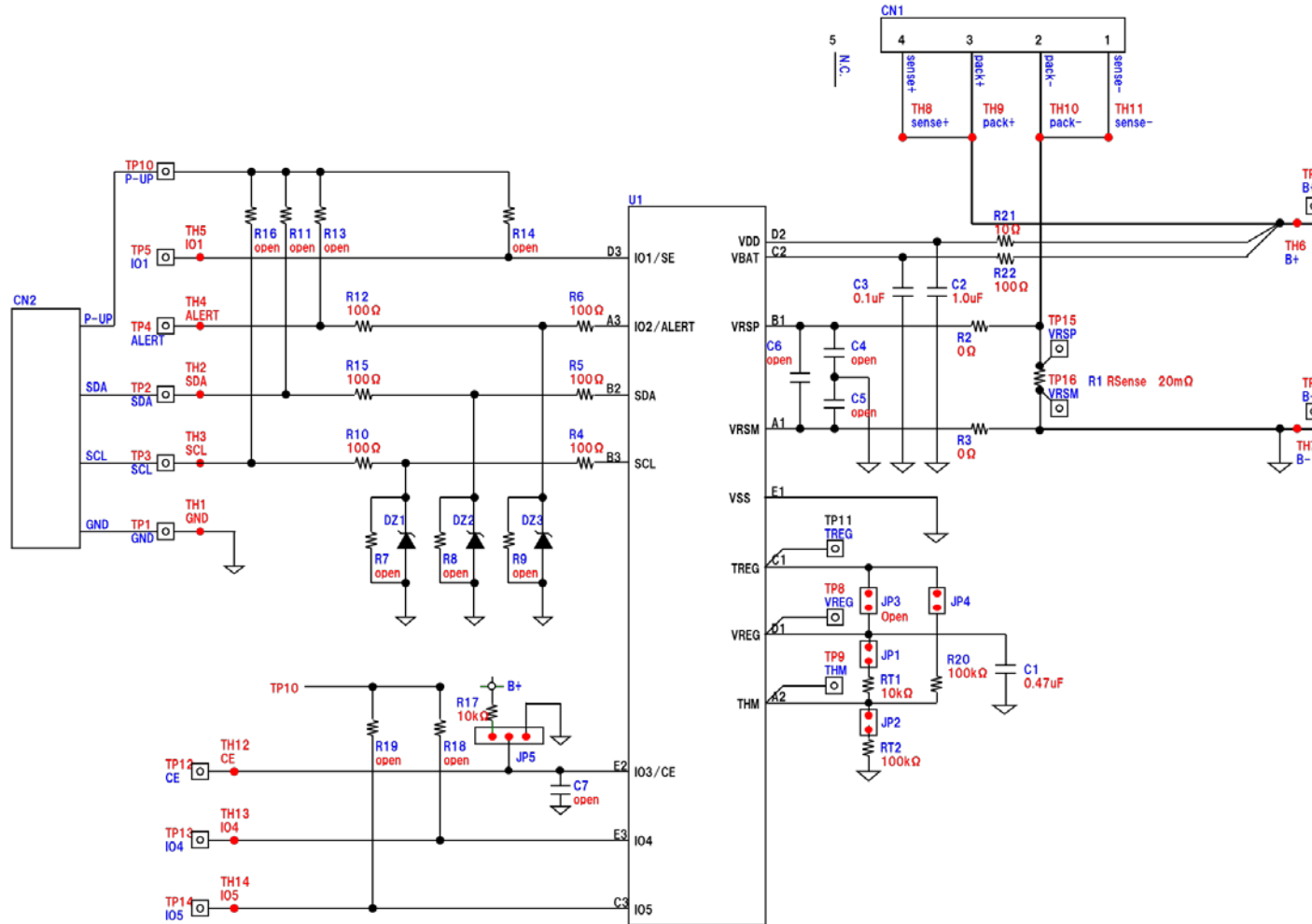

Figure 3. Eval Board Schematic

4. Software

4.1 EvaTool

The user can evaluate easily by using the software (EvaTool) which controls MM8118W02 to check the voltage/current/remaining capacity/etc. of MM8118W02 and to store Log data and to execute each sensor Calibration.

Please contact us to obtain EvaTool.

4.2 Ready to use EvaTool

1. Download VCP driver of FTDI Chip, and install it to the PC.
2. Connect the USB cable to the Interface Box and the PC.
3. Run EvaTool.
4. Select 「MM8118W02_EvaTool」 in 「Target Selection Wizard」 window. (Figure 4)
5. The main screen of EvaTool appears. (Figure 5)

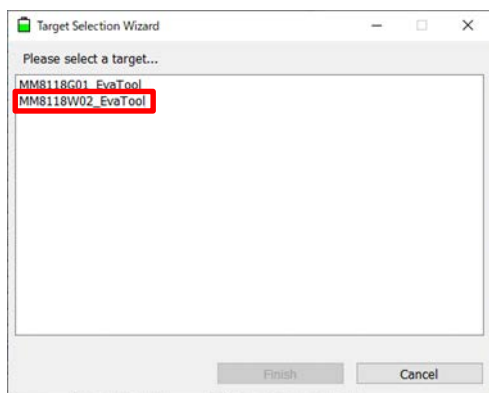

Figure 4. Target Selection Wizard



Figure 5. EvaTool main screen

4.3 Communication to Eval Board

1. Connect Interface Box and Eval Board.
(refer to P.4)
2. Click [I2C Pro] => [Port Scan] in order and select the COM number, then click [Connect].
(Figure 6)
3. Click [FG Data] => [Refresh] in order.
4. When the communication is successful, the current data is displayed in Value. (Figure 7)

※Refer to the document below for more detail.
[MM8118_AN030_StandardEvaluationKit_QuickStartGuide_rev1.●.pdf]

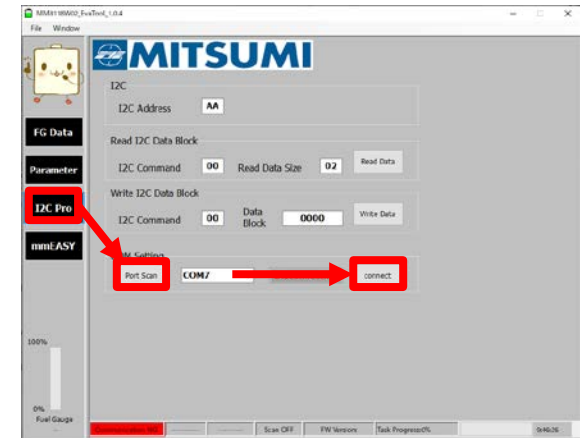

Figure 6. I2C Pro screen

4.4 EvaTool Basic Operation

- Refresh : update data once
- Start Logging : start to save Log continuously with any interval
- Stop Logging : stop to save Log
- Keep Scanning : update data continuously with any interval
- [Option] => [Set Scan And Logging Interval]
: set the interval of data update [0ms~600000ms]

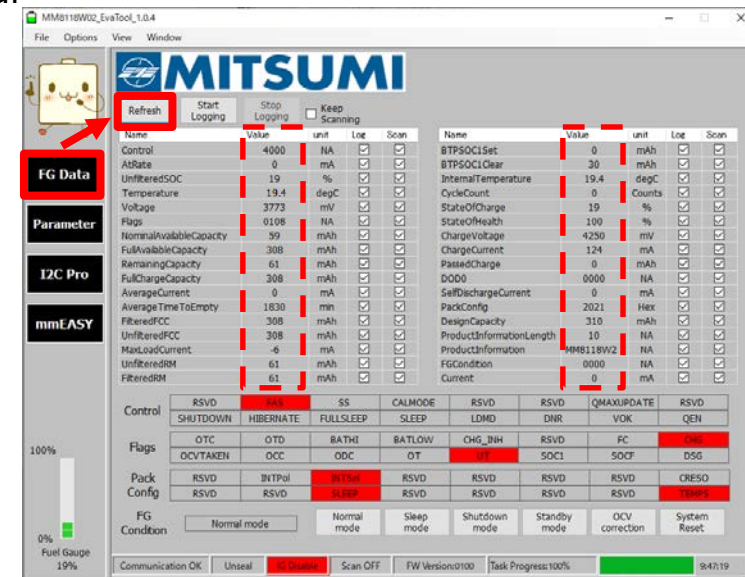

Figure 7. FG Data screen

4.5 Check Battery Parameter Data

1. Click 「Parameter」 => 「Read All」 in order
2. Battery Parameter data which is written in MM8118W02 is displayed in Value column.

4.6 Make Battery Parameter

If the actual use battery and battery parameter condition is different in MM8118W02, the accuracy of remaining capacity gets worse.

The user can make battery parameter easily by using the software 「ParameterEditor」 from the basic data of the use battery.

The accuracy of remaining capacity improves by writing the made battery parameter to MM8118W02 using EvaTool.

Please contact us to obtain 「ParameterEditor」 and please refer the document below for 「ParameterEditor」 usage.
「MM8118_AN031_ParameterEditorToolGuide_rev 1.●.pdf」.

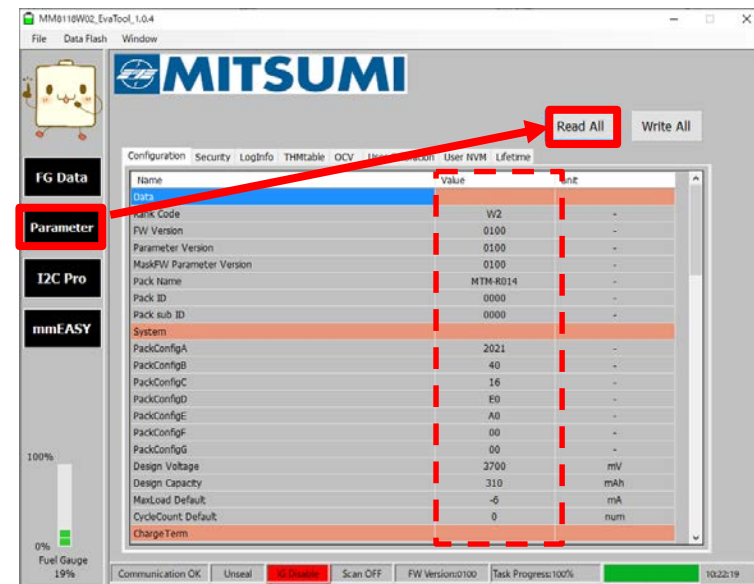

Figure 8. Battery Parameter data check

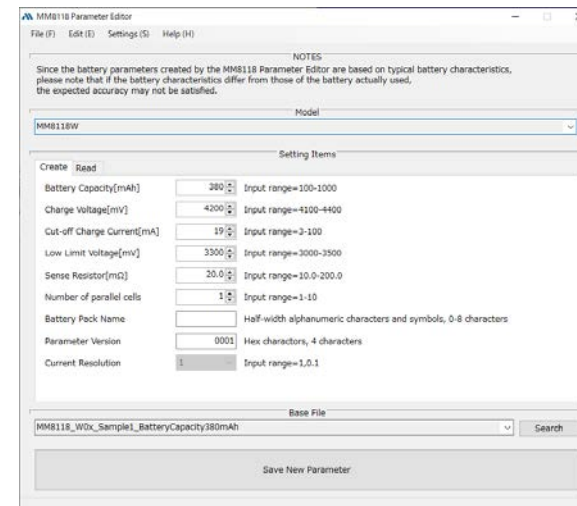

Figure 9. ParameterEditor screen

4.7 Write Battery Parameter

To write battery parameter, follow the steps below. (Figure 10)

1. Click 「mmEASY」
2. Drag and drop the battery parameter file made by 「ParameterEditor」 in 「Step 1」 area, or click 「Browse」 and select it.
3. If you want to start the evaluation right after the battery parameter write finished, check 「IG_Enable set」.
4. Click 「Write」.

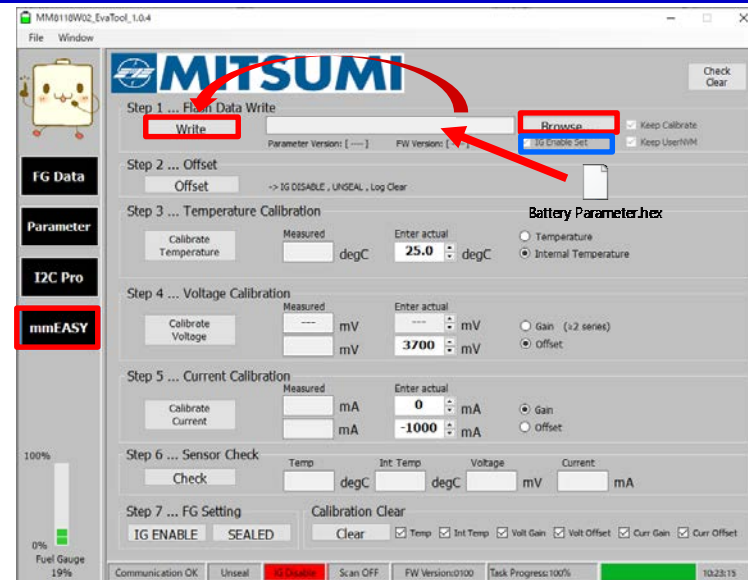

Figure 10. Battery Parameter Write

4.8 Each Sensors Calibration

MM8118W02 has voltage sensor, current sensor, IC temperature sensor and thermistor, and needs Calibration (adjustment) for these sensors.

Please refer the document below for the calibration procedure.
「MM8118_AN030_StandardEvaluationKit_Quick StartGuide_rev1.●.pdf」

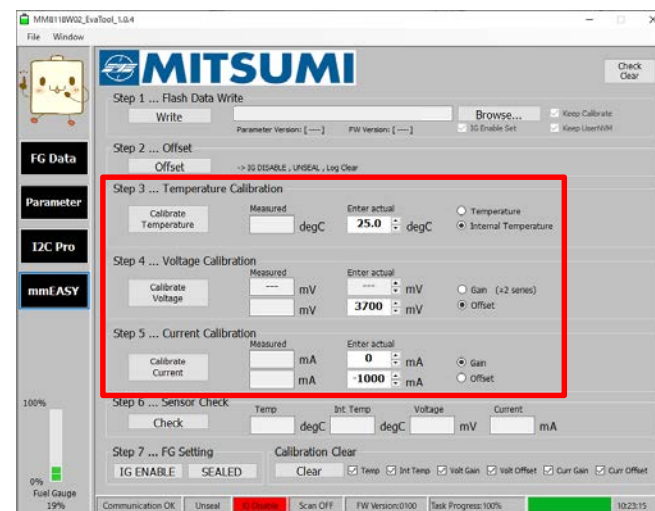

Figure 11. Calibration

【Safety Precautions】

• Though Mitsumi Electric Co., Ltd. (hereinafter referred to as "Mitsumi") works continually to improve our product's quality and reliability, semiconductor products may generally malfunction or fail. Customers are responsible for complying with safety standards and for providing adequate designs and safeguards for their hardware, software and systems which minimize risk and avoid situations in which a malfunction or failure of this product could cause loss of human life, bodily injury, or damage to property, including data loss or corruption. Before customers use this product, create designs including this product, or incorporate this product into their own applications, customers must also refer to and comply with (a) the latest versions or all of our relevant information, including without limitation, product specifications, data sheets and application notes for this product and (b) the user's manual, handling instructions or all relevant information for any products which is to be used, or combined with this products. Customers are solely responsible for all aspects of their own product design or applications, including but not limited to (a) determining the appropriateness of the use of this product in such design or applications; (b) evaluating and determining the applicability of any information contained in this document, or in charts, diagrams, programs, algorithms, sample application circuits, or any other referenced documents; and (c) validating all operating parameters for such designs and applications. Mitsumi assumes no liability for customers' product design or applications.

• This product is intended for applying to computers, OA units, communication units, instrumentation units, machine tools, industrial robots, AV units, household electrical appliances, and other general electronic units.

【Precautions for Product Liability Act】

• No responsibility is assumed by us for any consequence resulting from any wrong or improper use or operation, etc. of this product.

【ATTENTION】

• This product is designed and manufactured with the intention of normal use in general electronics. No special circumstance as described below is considered for the use of it when it is designed. With this reason, any use and storage under the circumstances below may affect the performance of this product. Prior confirmation of performance and reliability is requested to customers.

Environment with strong static electricity or electromagnetic wave

Environment with high temperature or high humidity where dew condensation may occur

• This product is not designed to withstand radioactivity, and must avoid using in a radioactive environment.

• This specification is written in Japanese and English. The English text is faithfully translated into the Japanese. However, if any question arises, Japanese text shall prevail.