

		PANEL THICKNESS AND HARDWARE INSTALLATION															
		12BW07 - LARGE SHOULDER NUT (K620)								12BW11 - SMALL SHOULDER NUT (K619)							
PANEL THICKNESS		0.050	0.055	0.060	0.065	0.070	0.075	0.080	0.085	0.090	0.095	0.100	0.105	0.110	0.115	0.120	0.125
WASHER (K178)		YES	YES	YES	YES	YES	NO	NO	NO	NO	YES	YES	YES	YES	YES	NO	NO

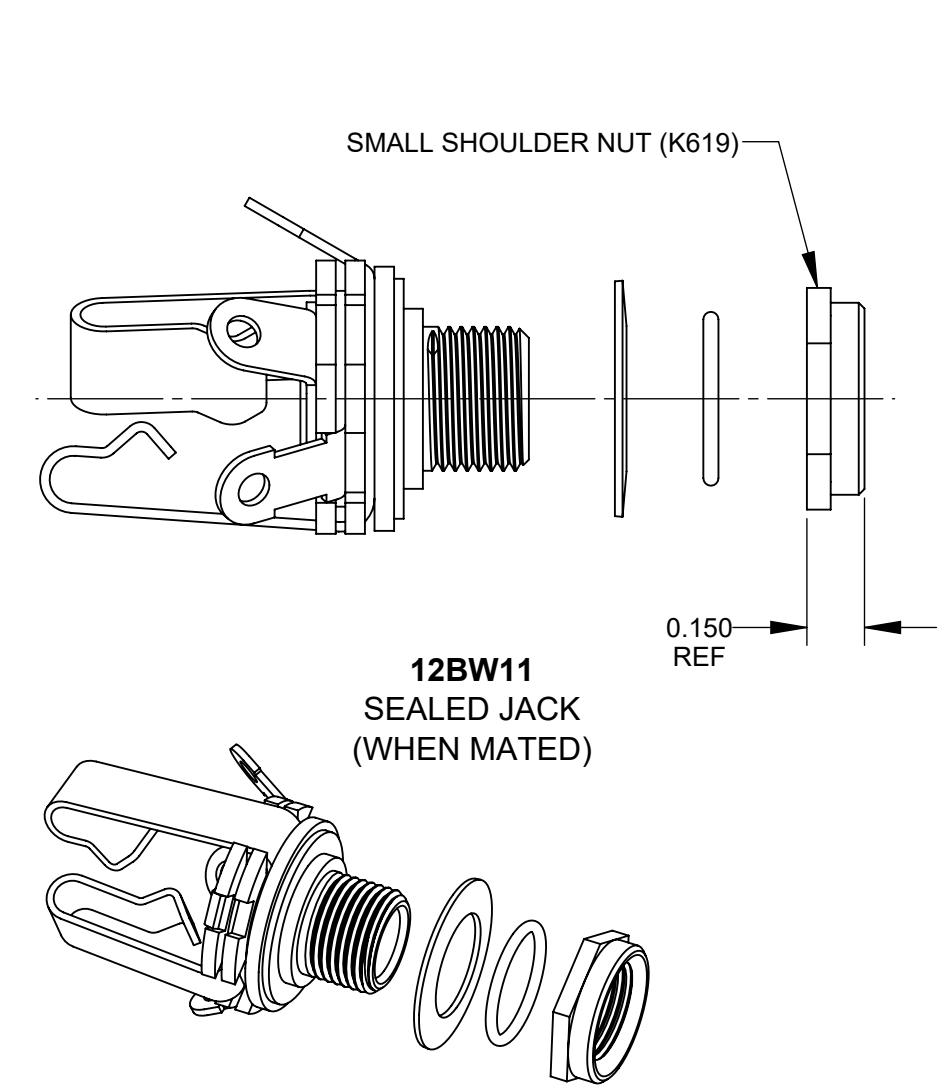
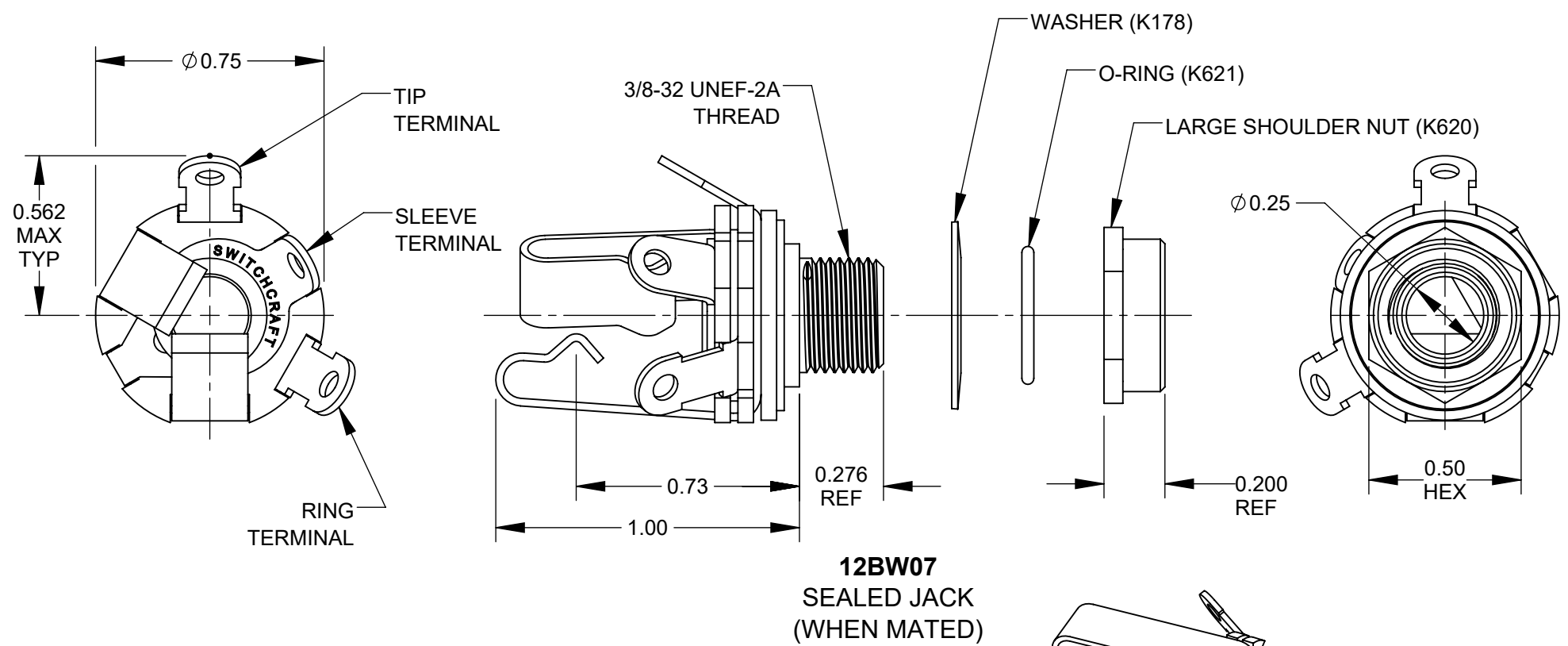

- NOTES:
- INSTALLATION - SEE THE PANEL THICKNESS AND HARDWARE INSTALLATION TABLE. INSTALL THE JACK AND THE WASHER (IF NEEDED) FROM THE BACK OF THE PANEL. INSTALL THE O-RING AND THEN THE SHOULDER NUT FROM THE FRONT OF THE PANEL. TIGHTEN THE NUT.
 - TO BE USED WITH SWITCHCRAFT 267S15-S28 SERIES PLUGS FOR IP66 RATING WHEN MATED.
 - RECOMMENDED MOUNTING HOLE: $\varnothing 0.375$ [9.5]
 - RECOMMENDED WORKING TEMPERATURE: -20 TO 50 °C.

5. MATERIALS:
- BUSHING - BRASS, NICKEL PLATED
 - INSULATING WASHERS, PHENOLIC
 - SLEEVE TERMINAL - BRASS, HOT TIN COATED
 - TIP & RING SPRING - NICKEL SILVER
 - O-RING - RUBBER
 - METAL WASHERS - STEEL, NICKEL PLATED
 - SHOULDER NUT - BRASS, NICKEL PLATED

6. THIS PRODUCT IS RoHS COMPLIANT.

REV	ECO NUMBER	DATE	BY	APVD
A	28492	5/18/22	TJK	TJK
REVISIONS				

UNLESS OTHERWISE SPECIFIED

- ALL DIMENSIONS IN INCHES [mm]
- TWO PLACE DECIMALS ± 0.02 [0.5]
- THREE PLACE DECIMALS ± 0.005 [0.13]

DO NOT SCALE DRAWING

THIS DRAWING DESCRIBES A DESIGN CONSIDERED PROPRIETARY IN NATURE, DEVELOPED AND MANUFACTURED BY SWITCHCRAFT INC. AND IS RELEASED ON A CONFIDENTIAL BASIS FOR IDENTIFICATION PURPOSES ONLY.									
SIZE	WIDTH	MULT	LBS/M	TEMPER					
FINISH					MATERIAL				
SPEC No.					SPEC No.				
FIRST USED ON					SCALE				
					2:1				
DATE DRAWN	BY	CHKD	APVD						
2/17/20	NS	NS	SRC						
			2/17/20						
NAME					PART No.				
SEALED 1/4" STEREO JACK, RoHS					12BW07-W11				
					REV				
					A				

CUSTOMER DRAWING