

Keywords: Digital, Digital Pot, Digital Potentiometer, digipot, DAC, D/A, D to A, digital to analog, resolution, buffer, speed, R-2R, serial, parallel, impedance, wiper, resistance, current, LED

## TUTORIAL 4025

# DACs vs. Digital Potentiometers: Which Is Right for My Application?

Apr 11, 2007

*Abstract: This application note compares digital to analog converters (DACs) to digital potentiometers. Traditionally digital potentiometers were meant to replace simple mechanical pots. With recent increases in resolution and additional features, digital potentiometers can also be used in some traditional DAC sockets. Similarly, traditional DAC packages were too big and too costly to compete against digital potentiometers. However, DAC pricing and package size have reduced significantly, so in some sockets a DAC or digital potentiometer can be used.*

## Introduction

Designers and procurement engineers whose applications require a finely tuned analog output controlled by a digital input have two options: digital potentiometers (pots) and digital-to-analog converters (DACs). Both devices use digital input signals to set an analog output. Digital potentiometers allow you to adjust an analog voltage, while DACs adjust current, voltage, or both. Potentiometers have three analog connections: the high connection, the wiper (or analog output), and a low connection (**Figure 1a**). DACs operate quite similarly, but not identically. In DACs the high connection is called the positive reference, the wiper called the DAC output, and the low connection is either connected to ground or occasionally bonded out as a negative reference connection (**Figure 1b**).

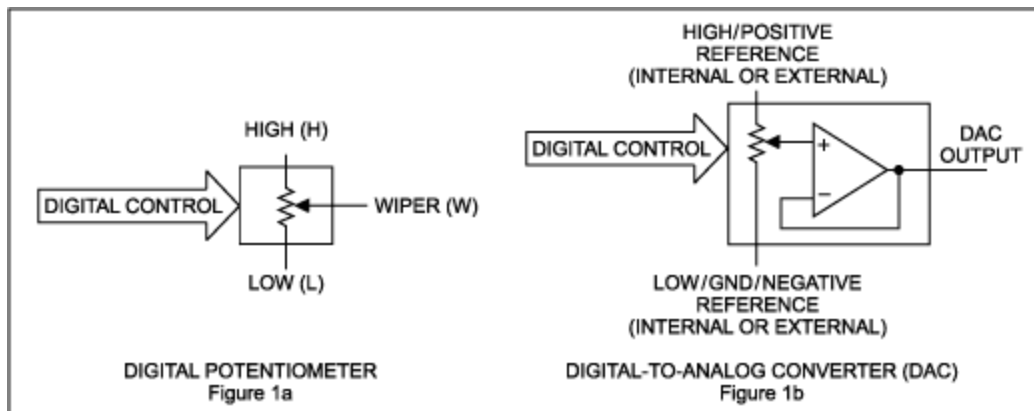

Figure 1. DACs traditionally incorporated an output buffer while digital potentiometers did not.

Traditionally digital potentiometers were intended to replace simple mechanical pots. (For more

information, see Application Note 3417: [Digital Potentiometers Replace Mechanical Pots](#).) With recent increases in resolution and additional features, however, digital potentiometers can also be used in some traditional DAC sockets. DACs and digital potentiometers have a few distinct differences. The most important difference is that DACs usually include an output amplifier/buffer while digital potentiometers do not. Most digital potentiometers cannot drive low-impedance loads without an external buffer. For some applications, the choice between DACs and digital potentiometers is clear. There are many applications, however, where either a DAC or a potentiometer will produce the desired result.

This article contrasts DACs with digital potentiometers to help you determine which is best for your application.

## Basic DAC Characteristics and Advantages

A DAC generally incorporates either a resistor-string architecture or an R-2R ladder architecture. When a resistor string is used, the DAC's inputs control a set of switches that divide the reference voltage through matched series resistors. A DAC R-2R ladder divides down a positive reference voltage by switching individual resistors between a positive reference voltage and the negative side of this reference voltage (usually ground), thus generating a current. A voltage-output DAC converts this current back to an output voltage through an output amplifier. A current-output DAC either routes the R-2R ladder current to the output directly, or uses an amplifier to buffer the output.

Selecting a DAC involves a number of choices, including: serial vs. parallel interface; resolution/number of bits; number of input channels; voltage or current output; cost; and relative accuracy.

A DAC communicates digitally with either a serial or a parallel interface. Serial interfaces send data sequentially, one bit after another on a single input or output line. Parallel interfaces send all the data bits at the same time and require a separate pin/connection for each bit. Serial interfaces typically divide into two categories: 3-wire (SPI™, QSPI™, or MICROWIRE™-compatible) or 2-wire (I<sup>2</sup>C). Some 3-wire interfaces that include a digital data output line are called 4-wire interfaces. For simplicity, however, this article refers to those latter interfaces as 3-wire.

For applications where speed is important, parallel interfaces are a preferred choice. Where size and cost are important, however, 3-wire and 2-wire serial interfaces are a good option, as they require fewer pins and typically cost less. A few 3-wire interfaces operate up to 26MHz while 2-wire interfaces currently operate up to 3.4MHz. For applications that require multiple DACs daisy-chained in series, choose a 3-wire serial interface. Both 3-wire and 2-wire interfaces can read back data written to the DAC. The ability to read back data is yet another advantage DACs hold over digital potentiometers.

Another DAC advantage is resolution. The highest resolution DACs are designed with 16- or 18-bit inputs to provide resolution down to the microvolt range. An 18-bit DAC, for example, with a 2.5V reference has a least significant bit (LSB) weight of 9.54μV. This degree of resolution is important for industrial designs such as robots or motors. In contrast, the largest resolution digital potentiometers currently feature 10-bit control, or 1024 taps.

DACs are available with many data converters integrated in a single package. As an example, the [MAX5733](#) features 32 DAC outputs, each output offering 16 bits of resolution. Digital potentiometers, however, are currently designed with a maximum of six channels. The [DS3930](#) is presently one of the few potentiometers with six digital potentiometers in a single package.

DACs drive current or voltage outputs through a combination of R-2R ladders or resistor strings, output amplifiers, and MOSFETs. The most significant difference between the majority of DACs and digital pots is the DAC's output amplifier. The output amplifier allows DACs to drive low impedance loads. However,

a few potentiometers are now being produced with output amplifiers.

DAC outputs sink and source current, which provides additional flexibility for designers. The [MAX5550's](#) 10-bit DAC output is internally routed through an amplifier, p-channel MOSFET, and pullup resistor to provide a current output capable of sourcing up to 30mA. Conversely, the 10-bit [MAX5547](#) combines an amplifier, n-channel MOSFET, and pulldown resistor to provide a current output capable of sinking up to 3.6mA. In addition to current outputs, some DACs have the amplifier connections bonded out to allow additional output control. This last group of DACs is known as force/sense DACs.

Because DACs often incorporate an internal amplifier, they typically cost more than digital potentiometers. However, DAC manufacturers continue to produce DACs in smaller and smaller packages, and thus their cost continues to decrease.

## Basic Digital Potentiometer Characteristics and Advantages

As discussed previously, digital potentiometers allow you to control resistance using digital inputs. The three-terminal digital potentiometer shown in Figure 1a above is essentially an adjustable resistive divider with a fixed end-to-end resistance. Digital potentiometers can be configured as a two-terminal variable resistor by connecting the wiper to either the high or low end, or by floating either the high or low end. Unlike DACs, digital potentiometers can operate with the H connection for the highest voltage with the L connection for the lowest voltage, or vice versa.

Selecting a digital potentiometer also involves a number of choices: linear or log taper and resolution/number of taps; nonvolatile memory; cost; and interface, with up/down, pushbutton, SPI, and I<sup>2</sup>C options available.

Linear potentiometers are more common than log-taper potentiometers. Each of the resistors in a linear potentiometer is equal to the other, so the steps from the low connection to the high connection yield a linear transfer function. Log-taper potentiometers, however, are generally designed to accommodate the wide range of audio signals. This is because the number of decibels of attenuation per step increases as the steps increase, thus better reproducing the response of the human ear.

Digital potentiometers communicate through several types of interface: I<sup>2</sup>C and SPI; a 2-wire up/down interface; a 3-wire interface slightly different from SPI; or a pushbutton up/down interface. The [MAX5456](#) 32-tap log potentiometer incorporates a form of the 2-wire pushbutton interface where its two digital connections can shift the wiper up or down, or the balance of the audio left or right.

## Applications that Complicate DAC/Potentiometer Selection

Many applications clearly require a DAC. A high-resolution motor, sensor, or robotics application typically requires the resolution of a DAC. High-speed applications such as base stations and instrumentation products require the speed, resolution, and even the parallel interface in a DAC.

An amplifier feedback network is one application where a potentiometer is easier to implement because of the digital potentiometer's linearity. Log potentiometers are better suited than DACs for attenuating an audio signal.

However, the traditional lines between DACs and digital potentiometers are beginning to blur. **Figure 2** shows an example where either a DAC or a digital potentiometer can control the [MAX1553](#) LED driver's brightness. In this case, the DC voltage at the MAX1553's BRT input and the value of the sense resistor from FB to GND determine the LED current level.

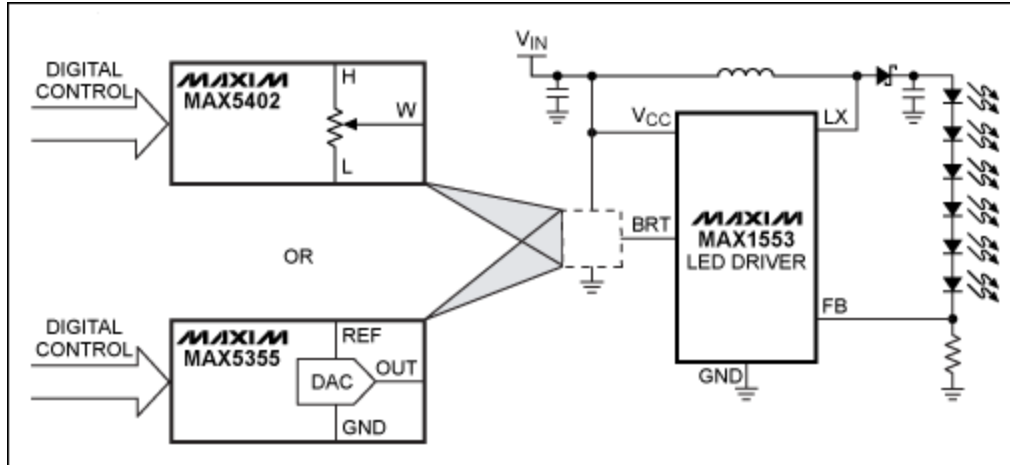

Figure 2. The voltage level on the MAX1553's BRT pin is set with a digital potentiometer or a DAC to fine-tune the LED current through a digital input.

A similar article appeared in the April 2006 online edition of *Electronic Products*.

MICROWIRE is a registered trademark of National Semiconductor Corporation.

QSPI is a trademark of Motorola, Inc.

#### Related Parts

<a href="#">DS3930</a>	Hex Nonvolatile Potentiometer with I/O and Memory	<a href="#">Free Samples</a>
<a href="#">MAX1553</a>	High-Efficiency, 40V Step-Up Converters for 2 to 10 White LEDs	<a href="#">Free Samples</a>
<a href="#">MAX5355</a>	10-Bit Voltage-Output DACs in 8-Pin $\mu$ MAX	<a href="#">Free Samples</a>
<a href="#">MAX5402</a>	256-Tap, $\mu$ PoT Low-Drift, Digital Potentiometer	<a href="#">Free Samples</a>
<a href="#">MAX5456</a>	Stereo Audio Taper Potentiometers with Pushbutton Interface	<a href="#">Free Samples</a>
<a href="#">MAX5547</a>	Dual, 10-Bit, Current-Sink Output DAC	<a href="#">Free Samples</a>
<a href="#">MAX5550</a>	Dual, 10-Bit, Programmable, 30mA High-Output-Current DAC	<a href="#">Free Samples</a>

#### More Information

For Technical Support: <http://www.maximintegrated.com/support>

For Samples: <http://www.maximintegrated.com/samples>

Other Questions and Comments: <http://www.maximintegrated.com/contact>

Application Note 4025: <http://www.maximintegrated.com/an4025>

TUTORIAL 4025, AN4025, AN 4025, APP4025, Appnote4025, Appnote 4025

Copyright © by Maxim Integrated Products

Additional Legal Notices: <http://www.maximintegrated.com/legal>