

REVISION HISTORY				
ECO	REV	DESCRIPTION	APPROVED	DATE
-	3	PRODUCTION	MM	7-24-19

HIGH EFFICIENCY BOOST

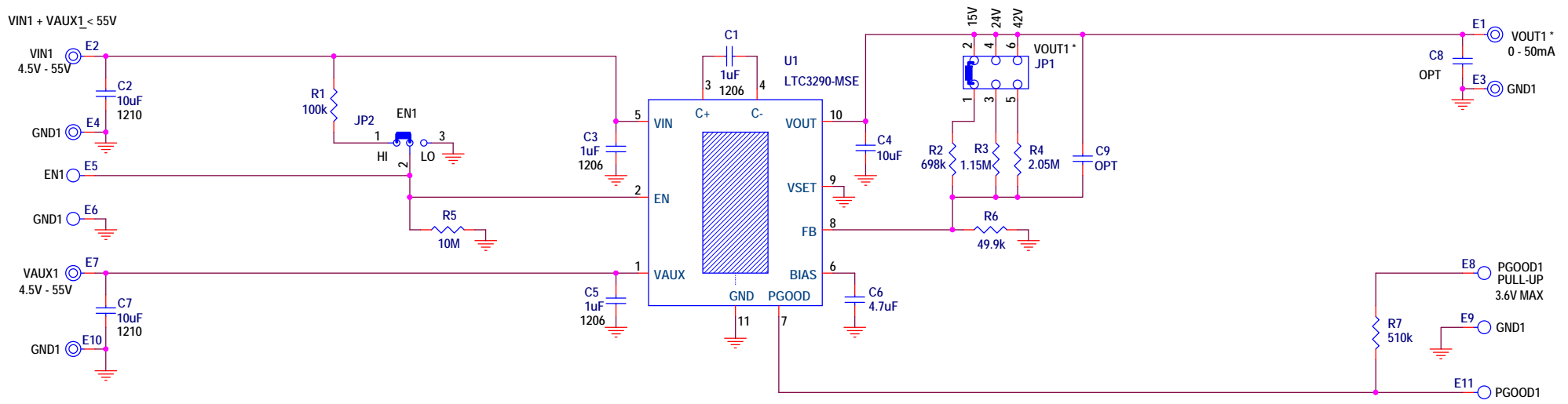

PCA ADDITIONAL PARTS

MP1	STANDOFF,NYLON,SNAP-ON,0.25" (6.4mm)
MP2	STANDOFF,NYLON,SNAP-ON,0.25" (6.4mm)
MP3	STANDOFF,NYLON,SNAP-ON,0.25" (6.4mm)
MP4	STANDOFF,NYLON,SNAP-ON,0.25" (6.4mm)
LB1	LABEL
PCB1	PCB, DC2585A REV03
STNCL1	TOOL, STENCIL, DC2585A REV03

CUSTOMER NOTICE

LINEAR TECHNOLOGY HAS MADE A BEST EFFORT TO DESIGN A CIRCUIT THAT MEETS CUSTOMER-SUPPLIED SPECIFICATIONS; HOWEVER, IT REMAINS THE CUSTOMER'S RESPONSIBILITY TO VERIFY PROPER AND RELIABLE OPERATION IN THE ACTUAL APPLICATION. COMPONENT SUBSTITUTION AND PRINTED CIRCUIT BOARD LAYOUT MAY SIGNIFICANTLY AFFECT CIRCUIT PERFORMANCE OR RELIABILITY. CONTACT LINEAR TECHNOLOGY APPLICATIONS ENGINEERING FOR ASSISTANCE.

THIS CIRCUIT IS PROPRIETARY TO LINEAR TECHNOLOGY AND SUPPLIED FOR USE WITH LINEAR TECHNOLOGY PARTS.

APPROVALS

PCB DES.	NC
APP ENG.	MM



www.analog.com

TITLE: SCHEMATIC	
HIGH VOLTAGE BOOST CHARGE PUMP	
IC NO. LTC3290 SKU NO. DC2585A	SCHEMATIC NO. AND REVISION: 710-DC2585A_REV03
SIZE: N/A	DATE: 07-24-19
SHEET 1 OF 2	

REVISION HISTORY				
ECO	REV	DESCRIPTION	APPROVED	DATE
-	3	PRODUCTION	MM	7-25-19

VIN TRACKING BOOST

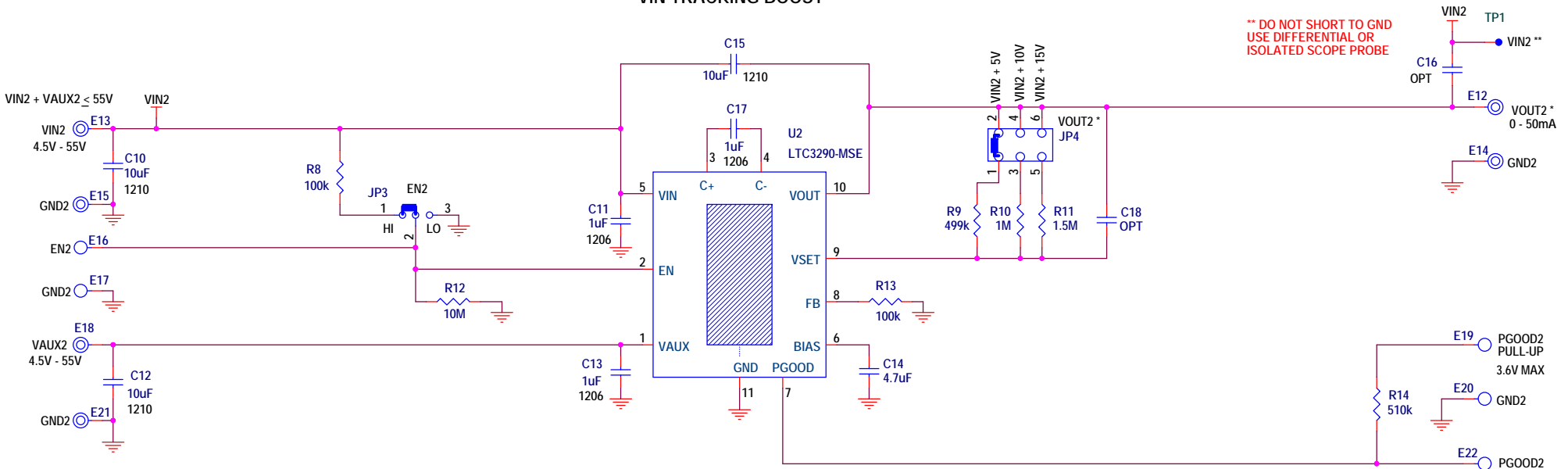

CUSTOMER NOTICE

LINEAR TECHNOLOGY HAS MADE A BEST EFFORT TO DESIGN A CIRCUIT THAT MEETS CUSTOMER-SUPPLIED SPECIFICATIONS; HOWEVER, IT REMAINS THE CUSTOMER'S RESPONSIBILITY TO VERIFY PROPER AND RELIABLE OPERATION IN THE ACTUAL APPLICATION. COMPONENT SUBSTITUTION AND PRINTED CIRCUIT BOARD LAYOUT MAY SIGNIFICANTLY AFFECT CIRCUIT PERFORMANCE OR RELIABILITY. CONTACT LINEAR TECHNOLOGY APPLICATIONS ENGINEERING FOR ASSISTANCE.

THIS CIRCUIT IS PROPRIETARY TO LINEAR TECHNOLOGY AND SUPPLIED FOR USE WITH LINEAR TECHNOLOGY PARTS.

APPROVALS

PCB DES.	NC
APP ENG.	MM



www.analog.com

TITLE: SCHEMATIC
HIGH VOLTAGE BOOST CHARGE PUMP

IC NO. LTC3290
SKU NO. DC2585A

SCHEMATIC NO. AND REVISION:
710-DC2585A_REV03

SIZE: N/A DATE: 07-24-19

SHEET 2 OF 2