

PCB LAYOUT: COMPONENT SIDE
RECOMMEND PCB THICKNESS: .094/2.40

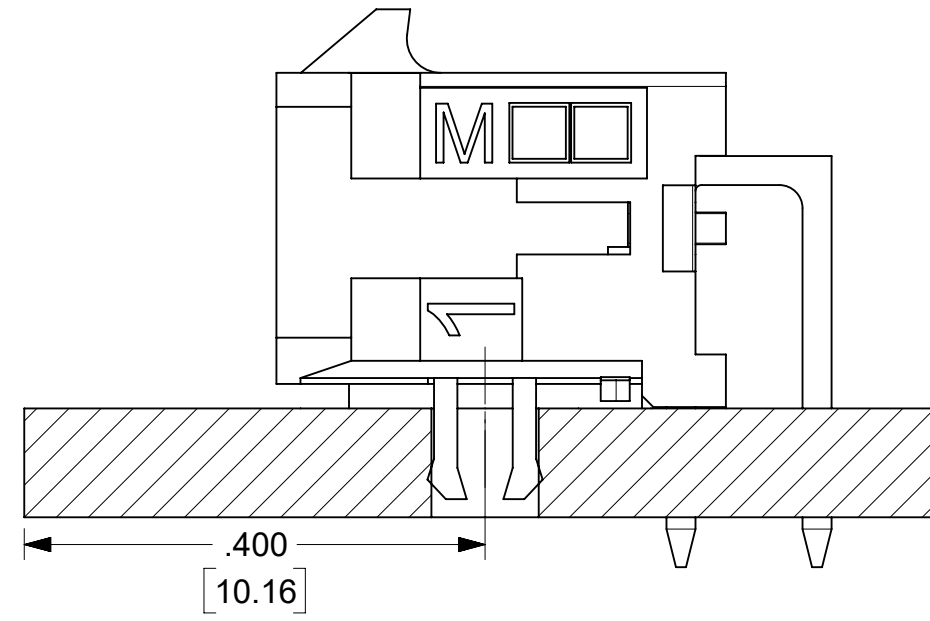
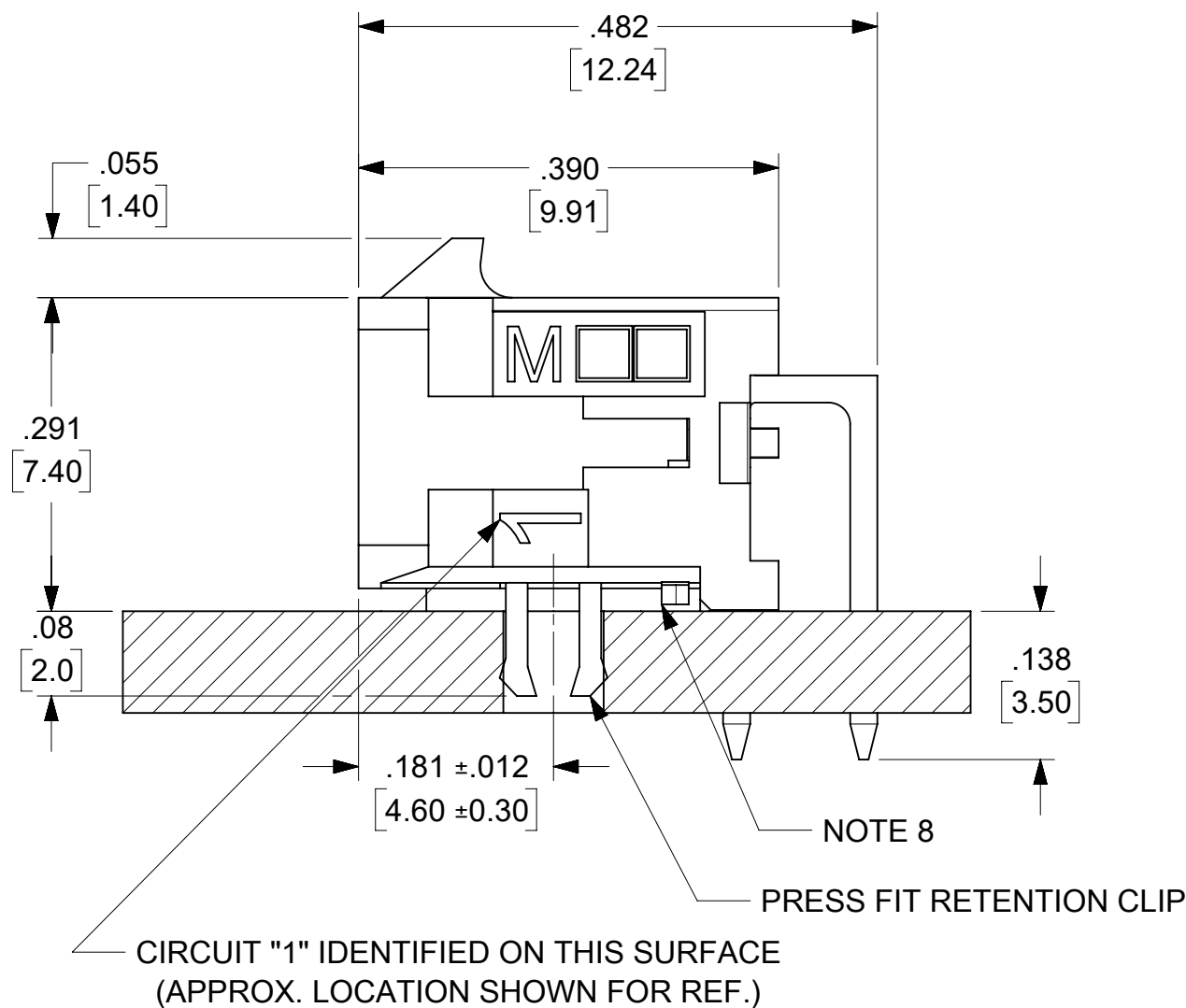
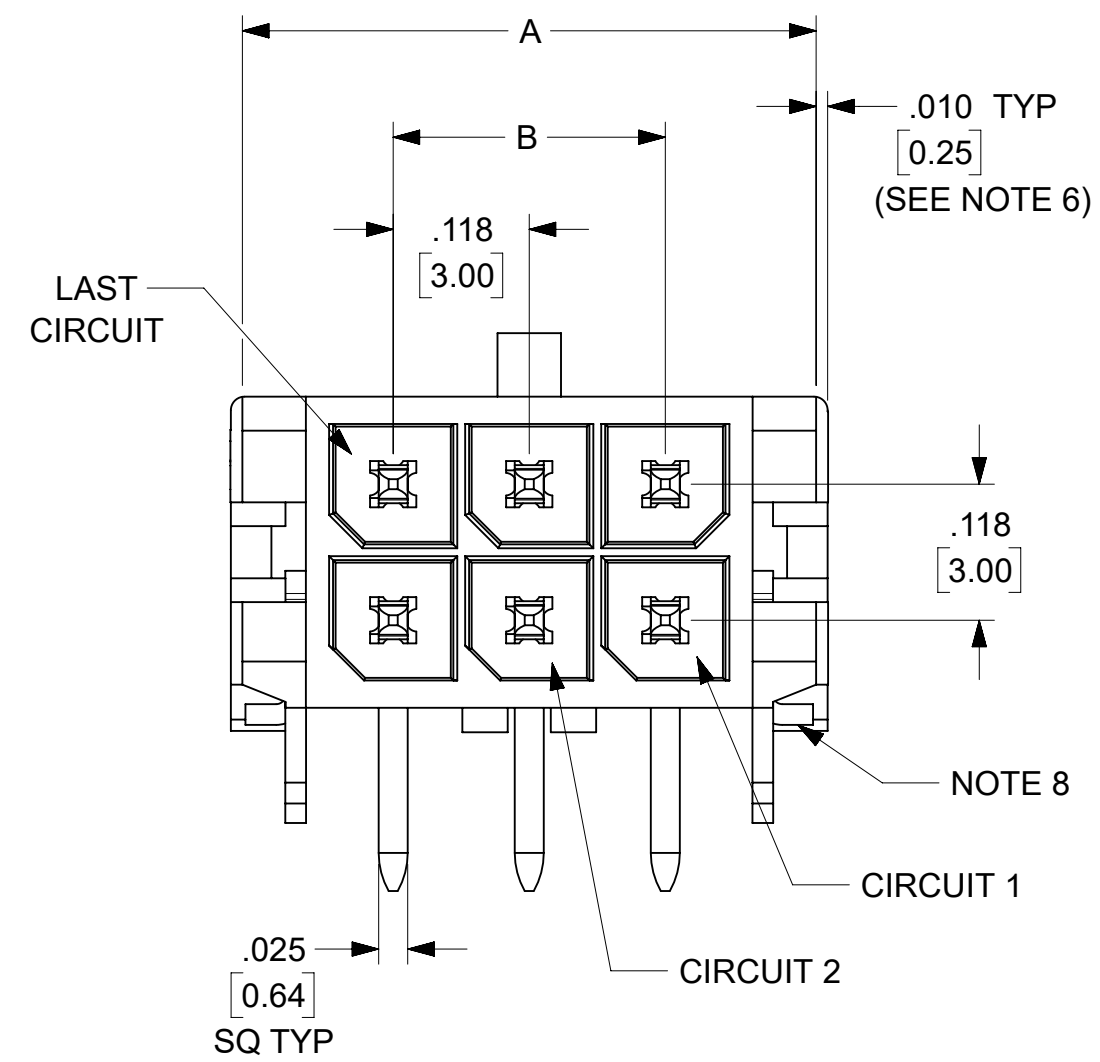

LOCATION DETAIL
SEE NOTE #7

- NOTES:**
- HOUSING MATERIAL: GLASS FILLED LIQUID CRYSTAL POLYMER UL94V-0, COLOR: BLACK
TERMINAL MATERIAL: BRASS ALLOY
 - FINISH: .000015/(0.00038) MIN SELECT GOLD IN CONTACT AREA,
.000100/(0.00254) MIN. SELECT MATTE TIN ON SOLDER TAILS,
BOTH OVER .000050/(0.00127) MIN. NICKEL PLATE
 - PRODUCT SPECIFICATION: PS-43045
 - TRAY PACKAGED: SEE MOLEX DRAWING PK-70873-0313
 - MATES WITH MICRO-FIT (3.0) RECEPTACLE SERIES 43025
 - CIRCUIT SIZES 2-6: 'D' IS .265/6.74 FOR .010/(0.25) STEP
CIRCUIT SIZES 8-24: 'D' IS .063/(1.60) FOR .010/(0.25) STEP
 - TO AVOID INTERFERENCE BETWEEN RECEPTACLE AND PCB, HEADER MUST BE PLACED WITHIN .400/(10.16) MAX. FROM EDGE OF PCB, ASH SHOWN IN LOCATION DETAIL.
 - METAL TAB MAY BE FLUSH WITH PCB.
 - THIS PART CONFORMS TO CLASS B REQUIREMENTS OF COSMETIC SPECIFICATION PS-45499-002.
 - COMPLIANT RoHS DIRECTIVE 2011/65/EU AND ELV.
 - FOR BEST RETENTION TO PCB, HOLES SHOULD BE PTH AND CLIPS SHOULD BE SOLDERED
 - TEXT ON PART IS FOR REFERENCE ONLY. TEXT AND TEXT LOCATION MAY VARY DEPENDING ON PART NUMBER AND/OR TOOL

CKTS	MATERIAL NO:	A	B	C
02	43045-0230	.262		.169
		6.65	NA	4.30
04	43045-0430	.380	.118	.287
		9.65	3.00	7.30
06	43045-0630	.498	.236	.405
		12.65	6.00	10.30
08	43045-0830	.616	.354	.524
		15.65	9.00	13.30
10	43045-1030	.734	.472	.642
		18.65	12.00	16.30
12	43045-1230	.852	.591	.760
		21.65	15.00	19.30
14	43045-1430	.970	.709	.878
		24.65	18.00	22.30
16	43045-1630	1.088	.827	.996
		27.65	21.00	25.30
18	43045-1830	1.206	.945	1.114
		30.65	24.00	28.30
20	43045-2030	1.325	1.063	1.252
		33.65	27.00	31.30
22	43045-2230	1.443	1.181	1.350
		36.65	30.00	34.30
24	43045-2430	1.561	1.299	1.469
		39.65	33.00	37.30

FUNCTIONAL SYMBOLS	THIS DRAWING CONTAINS INFORMATION THAT IS PROPRIETARY TO MOLEX ELECTRONIC TECHNOLOGIES, LLC AND SHOULD NOT BE USED WITHOUT WRITTEN PERMISSION		CURRENT REV DESC: REDRAWN, ADD NOTES 11 & 12		
	INCH/MM	SCALE	6:1		
DIVISIONAL SYMBOLS	GENERAL TOLERANCES (UNLESS SPECIFIED)		EC NO: 736143		
	ANGULAR TOL ± 0.5°		DRWN: SETHH6 2022/12/14		
4 PLACES ±	3 PLACES ±		CHK'D: MKIPPER 2023/01/24		
2 PLACES ± 0.25	1 PLACE ± 0.4		APPR: FSMITH 2023/01/26		
0 PLACES ±	INITIAL REVISION:		DRWN: YTIAN30 2017/11/20		
DRAFT WHERE APPLICABLE MUST REMAIN WITHIN DIMENSIONS		THIRD ANGLE PROJECTION		APPR: AYIN 2017/12/14	
DRAWING		SERIES		MATERIAL NUMBER	
C-SIZE		43045		SEE CHART	
CUSTOMER		SHEET NUMBER		DOC PART	
GENERAL MARKET		1 OF 1		C1	