

Light is OSRAM

OSRAM

Our Brand

LED ENGIN



LuxiGen Multi-Color Emitter Series

LZP RGBW Flat Lens LED Emitter

LZP-04MD00

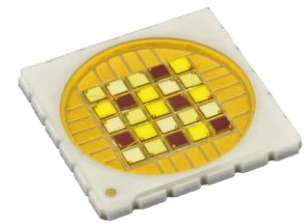

Key Features

- Highest flux density surface mount ceramic package RGBW LED with integrated flat glass lens
- 6.2mmx6.2mm Light Emitting Area with 80W power dissipation
- Ideal for narrow beam applications of less than 10° and light guide coupling
- Industry lowest thermal resistance per package footprint (0.5°C/W)
- Individually addressable Red, Green, Blue and Daylight White channels
- In-source mixing based on smart die positioning for optimum color uniformity
- Electrically neutral thermal path
- JEDEC Level 1 for Moisture Sensitivity Level
- Lead (Pb) free and RoHS compliant
- Emitter available on 4-channel MCPCB (optional)

Typical Applications

- Stage and Studio lighting
- Fountain lighting
- Accent lighting
- Effect lighting

LZP-04MD00

Part number options

Base part number

Part number	Description
LZP-04MD00-xxxx	LZP RGBW flat lens emitter
LZP-L4MD00-xxxx	LZP RGBW flat lens emitter on 4 channel Star MCPCB

Bin kit option codes

MD, Red-Green-Blue-White (6500K)

Kit number suffix	Min flux bin	Color bin range	Description
0000	20R	R01	Red, full distribution flux; full distribution wavelength
	22G	G2 – G3	Green, full distribution flux; full distribution wavelength
	23B	B03	Blue, full distribution flux; full distribution wavelength
	10W	W65	White full distribution flux and CCT

Daylight White Chromaticity Groups

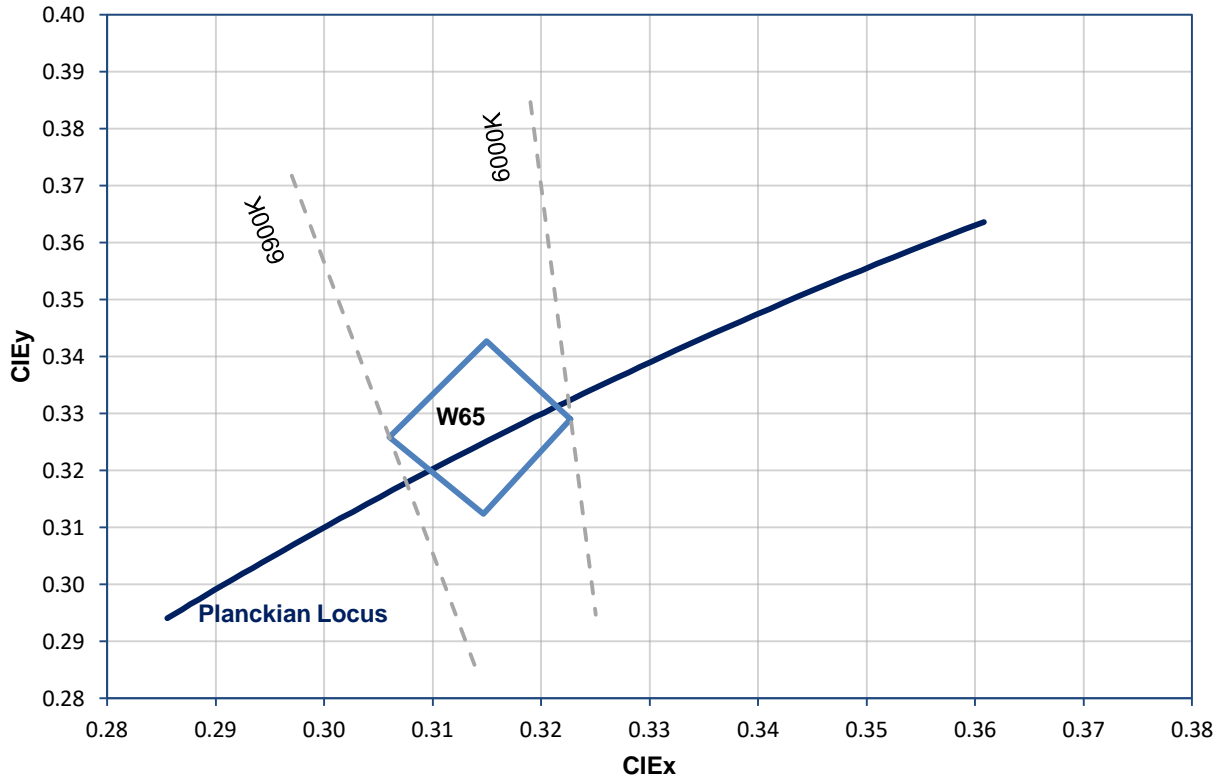

Standard Chromaticity Groups plotted on excerpt from the CIE 1931 (2°) x-y Chromaticity Diagram.

Coordinates are listed below

Daylight White Bin Coordinates

Bin Code	CIE x	CIE y
W65	0.3227	0.329
	0.315	0.3427
	0.306	0.3258
	0.3147	0.3123
	0.3227	0.329

Luminous Flux Bins

Table 1:

Bin Code	Minimum Luminous Flux (Φ_v) @ $I_F = 700\text{mA}$ ^[1] (lm)				Maximum Luminous Flux (Φ_v) @ $I_F = 700\text{mA}$ ^[1] (lm)			
	6 Red	6 Green	6 Blue	7 White	6 Red	6 Green	6 Blue	7 White
	20R	360				625		
22G		600				1000		
23B			130				210	
10W				1120				1785

Notes for Table 1:

- Luminous flux performance is measured at 10ms pulse, $T_C = 25^\circ\text{C}$; with all LED dice with the same color connected in series. LED Engin maintains a tolerance of $\pm 10\%$ on flux measurements.

Dominant Wavelength Bins

Table 2:

Bin Code	Minimum Dominant Wavelength (λ_D) @ $I_F = 700\text{mA}$ ^[1] (nm)			Maximum Dominant Wavelength (λ_D) @ $I_F = 700\text{mA}$ ^[1] (nm)		
	Red	Green	Blue	Red	Green	Blue
	R01	617			630	
G2		520			525	
G3		525			530	
B03			453			460

Notes for Table 2:

- Dominant wavelength is measured at 10ms pulse, $T_C = 25^\circ\text{C}$. LED Engin maintains a tolerance of $\pm 1.0\text{nm}$ on dominant wavelength measurements.

Forward Voltage Bins

Table 3:

Bin Code	Minimum Forward Voltage (V_F) @ $I_F = 700\text{mA}$ ^[1,2] (V)				Maximum Forward Voltage (V_F) @ $I_F = 700\text{mA}$ ^[1,2] (V)			
	6 Red	6 Green	6 Blue	7 White	6 Red	6 Green	6 Blue	7 White
	0	12.6	19.2	16.8	19.6	17.4	25.2	22.8

Notes for Table 3:

- Forward voltage is measured at 10ms pulse, $T_C = 25^\circ\text{C}$ with all LED dice with the same color connected in series.
- LED Engin maintains a tolerance of $\pm 0.24\text{V}$ for forward voltage measurements for 6 LEDs and $\pm 0.28\text{V}$ for 7 LEDs.

Absolute Maximum Ratings

Table 4:

Parameter	Symbol	Value	Unit
DC Forward Current ^[1]	I_F	1000	mA
Peak Pulsed Forward Current ^[2]	I_{FP}	1500	mA
Reverse Voltage	V_R	See Note 3	V
Storage Temperature	T_{stg}	-40 ~ +150	°C
Junction Temperature [Blue, Green, White]	T_J	150	°C
Junction Temperature [Red]	T_J	125	°C
Soldering Temperature ^[4]	T_{sol}	260	°C

Notes for Table 4:

- Maximum DC forward current is determined by the overall thermal resistance and ambient temperature. Follow the curves in Figure 11 for current derating.
- Pulse forward current conditions: Pulse Width \leq 10msec and Duty Cycle \leq 10%.
- LEDs are not designed to be reverse biased.
- Solder conditions per JEDEC 020D. See Reflow Soldering Profile Figure 5.
- LED Engin recommends taking reasonable precautions towards possible ESD damages and handling the LZP-04MD00 in an electrostatic protected area (EPA). An EPA may be adequately protected by ESD controls as outlined in ANSI/ESD S6.1.

Optical Characteristics @ $T_c = 25^\circ\text{C}$

Table 5:

Parameter	Symbol	Typical				Unit
		6 Red	6 Green	6 Blue ^[1]	7 White	
Luminous Flux (@ $I_F = 700\text{mA}$)	Φ_V	460	820	190	1470	lm
Luminous Flux (@ $I_F = 1000\text{mA}$)	Φ_V	640	1060	250	1900	lm
Dominant Wavelength	λ_D	623	523	457		nm
Correlated Color Temperature	CCT				6500	K
Color Rendering Index (CRI)	R_a				75	
Viewing Angle ^[2]	$2\Theta_{1/2}$		120			Degrees
Total Included Angle ^[3]	$\Theta_{0.9}$		160			Degrees

Notes for Table 5:

- When operating the Blue LED, observe IEC 62471 Risk Group 2 rating. Do not stare into the beam.
- Viewing Angle is the off axis angle from emitter centerline where the luminous intensity is $\frac{1}{2}$ of the peak value.
- Total Included Angle is the total angle that includes 90% of the total luminous flux.

LZP-04MD00

Electrical Characteristics @ T_C = 25°C

Table 6:

Parameter	Symbol	Typical				Unit
		6 Red	6 Green	6 Blue	7 White	
Forward Voltage (@ I _F = 700mA) ^[1]	V _F	15.0	21.6	19.2	22.4	V
Forward Voltage (@ I _F = 1000mA) ^[1]	V _F	16.2	22.4	19.9	23.3	V
Temperature Coefficient of Forward Voltage	ΔV _F /ΔT _J	-13.3	-17.4	-12.0	-12.0	mV/°C
Thermal Resistance (Junction to Case)	R _{ΘJ-C}		0.5			°C/W

Notes for Table 6:

- Forward Voltage typical value is for all LED dice from the same color dice connected in series.

IPC/JEDEC Moisture Sensitivity Level

Table 7 - IPC/JEDEC J-STD-20 MSL Classification :

Level	Soak Requirements					
	Floor Life		Standard		Accelerated	
	Time	Conditions	Time (hrs)	Conditions	Time (hrs)	Conditions
1	Unlimited	≤ 30°C/ 60% RH	168 +5/-0	85°C/ 60% RH	n/a	n/a

Notes for Table 7:

- The standard soak time includes a default value of 24 hours for semiconductor manufacturer's exposure time (MET) between bake and bag and includes the maximum time allowed out of the bag at the distributor's facility.

Average Lumen Maintenance Projections

Lumen maintenance generally describes the ability of a lamp to retain its output over time. The useful lifetime for solid state lighting devices (Power LEDs) is also defined as Lumen Maintenance, with the percentage of the original light output remaining at a defined time period.

Based on long-term HTOL testing, LED Engin projects that the LZP Series will deliver, on average, above 70% Lumen Maintenance at 20,000 hours of operation at a forward current of 700mA. This projection is based on constant current operation with junction temperature maintained at or below 120°C for LZP product.

LZP-04MD00

Mechanical Dimensions (mm)

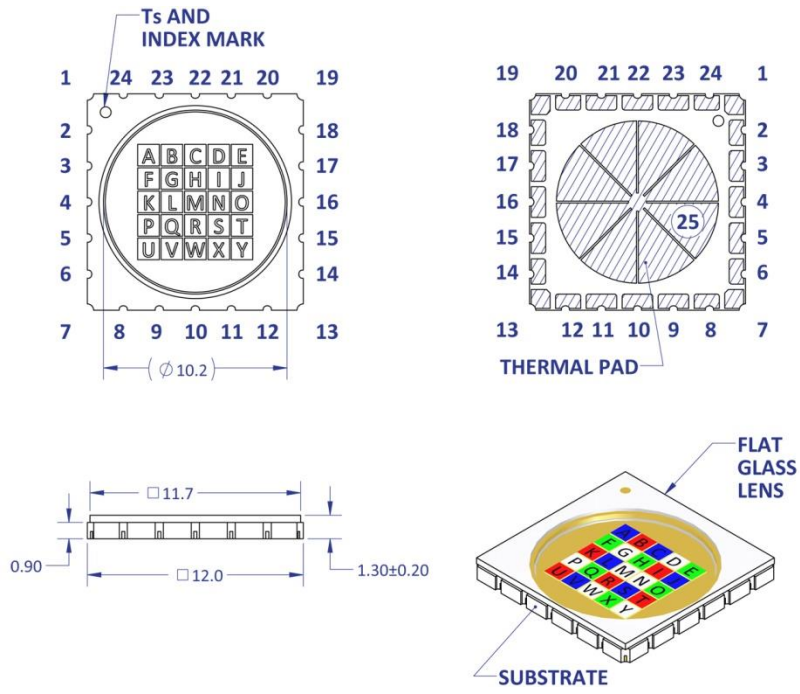

Figure 1: Package outline drawing

Notes for Figure 1:

1. Unless otherwise noted, the tolerance = ± 0.20 mm.
2. Thermal slug is electrically isolated.
3. Ts is a thermal reference point.

Pin Out				
Ch.	Pad	Die	Color	Function
1	18	B	Red	Anode
		I	Red	na
		K	Red	na
		R	Red	na
		T	Red	na
2	2	U	Red	Cathode
	17	E	Green	Anode
		F	Green	na
		H	Green	na
		O	Green	na
3	X	Green	Cathode	
3	15	A	Blue	Anode
		C	Blue	na
		J	Blue	na
		L	Blue	na
		S	Blue	na
4	5	V	Blue	Cathode
	14	D	CW	Anode
		G	CW	na
		M	CW	na
		N	CW	na
		P	CW	na
	W	CW	na	
6	Y	CW	Cathode	
DNC pins: 1,4,7,8,9,10,11,12,13,16,19,20,21,22,23,24.				

Note:

DNC = Do Not Connect (Electrically Non Isolated)

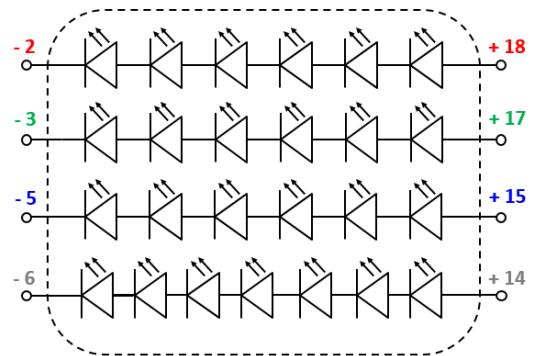

Recommended Solder Pad Layout (mm)

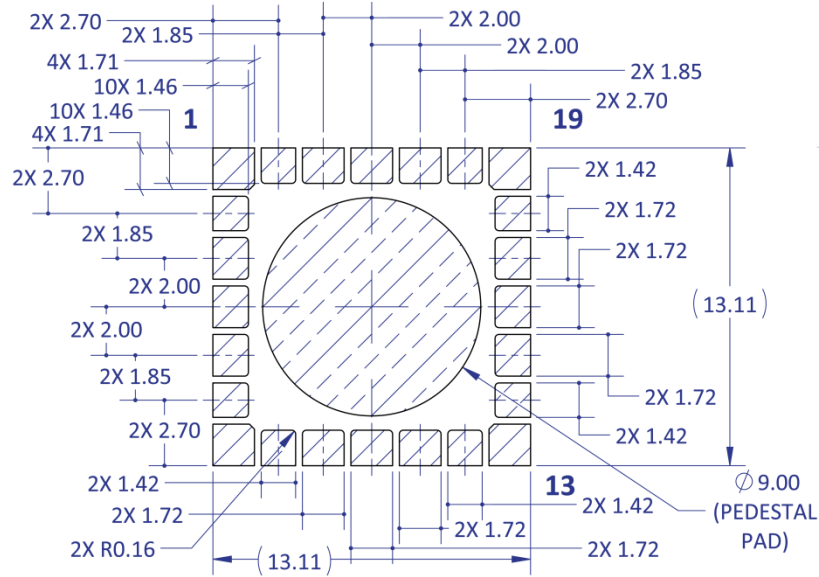

Figure 2a: Recommended solder mask opening (hatched area) for anode, cathode, and thermal pad

Notes for Figure 2a:

1. Unless otherwise noted, the tolerance = ± 0.20 mm.
2. LED Engin recommends the use of copper core MCPCB's which allow for the emitter thermal slug to be soldered directly to the copper core (so called pedestal design). Such MCPCB technologies eliminate the high thermal resistance dielectric layer that standard MCPCB technologies use in between the emitter thermal slug and the metal core of the MCPCB, thus lowering the overall system thermal resistance.
3. LED Engin recommends x-ray sample monitoring for solder voids underneath the emitter thermal slug. The total area covered by solder voids should be less than 20% of the total emitter thermal slug area. Excessive solder voids will increase the emitter to MCPCB thermal resistance and may lead to higher failure rates due to thermal over stress..

Recommended Solder Mask Layout (mm)

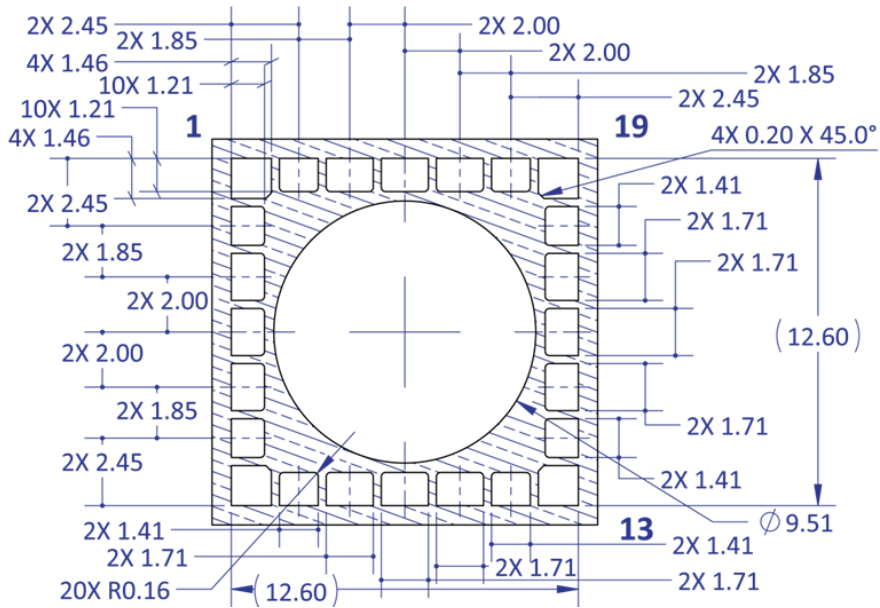

Figure 2b: Recommended solder mask opening for anode, cathode, and thermal pad

Note for Figure 2b:

1. Unless otherwise noted, the tolerance = ± 0.20 mm.

Typical Radiation Pattern

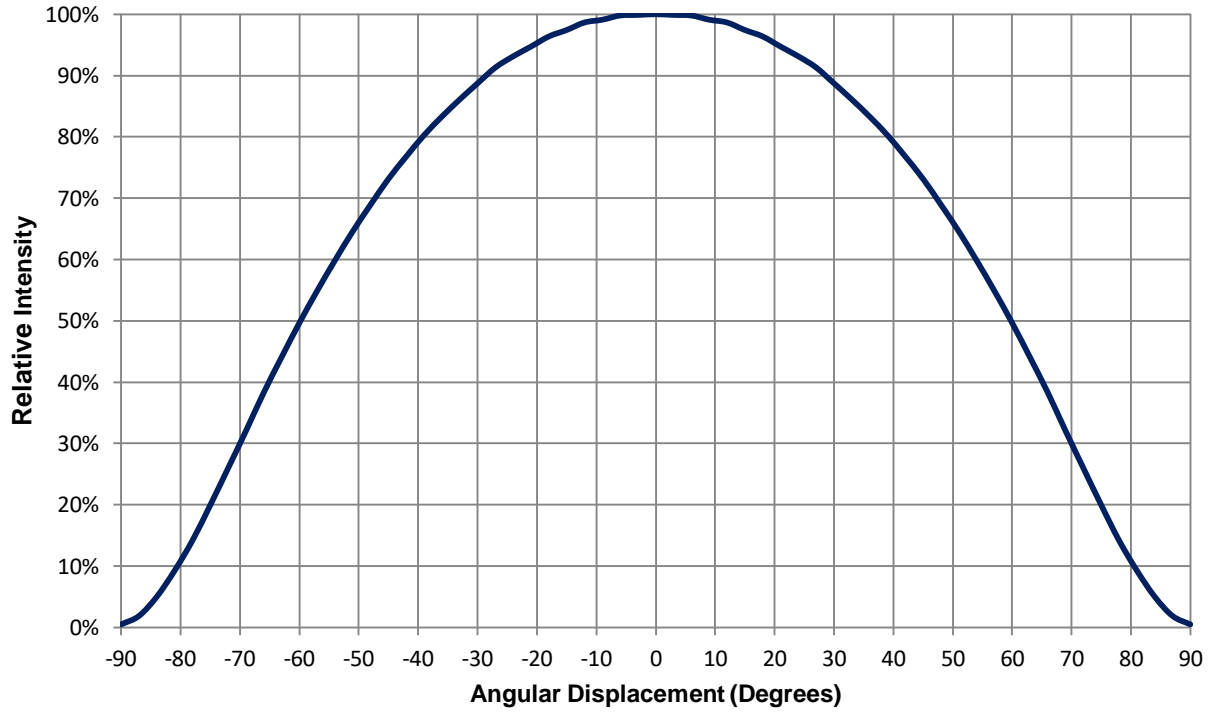

Figure 4: Typical representative spatial radiation pattern

Typical Relative Spectral Power Distribution

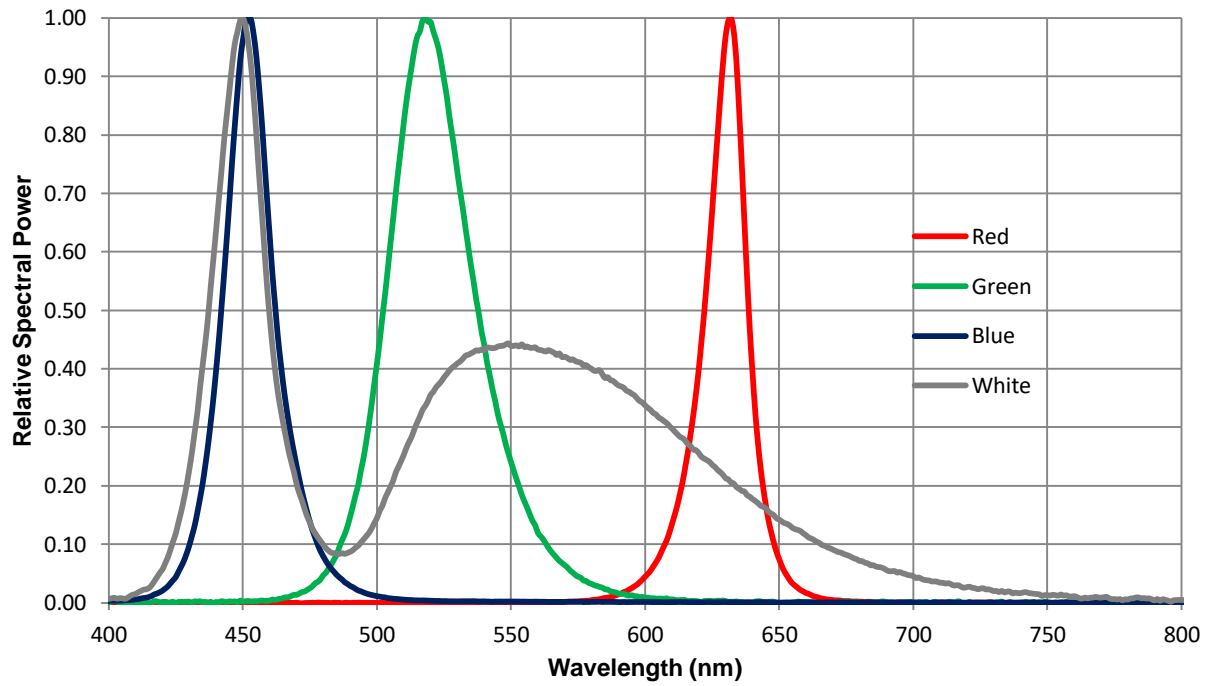

Figure 5: Typical relative spectral power vs. wavelength @ T_C = 25°C

Typical Forward Current Characteristics

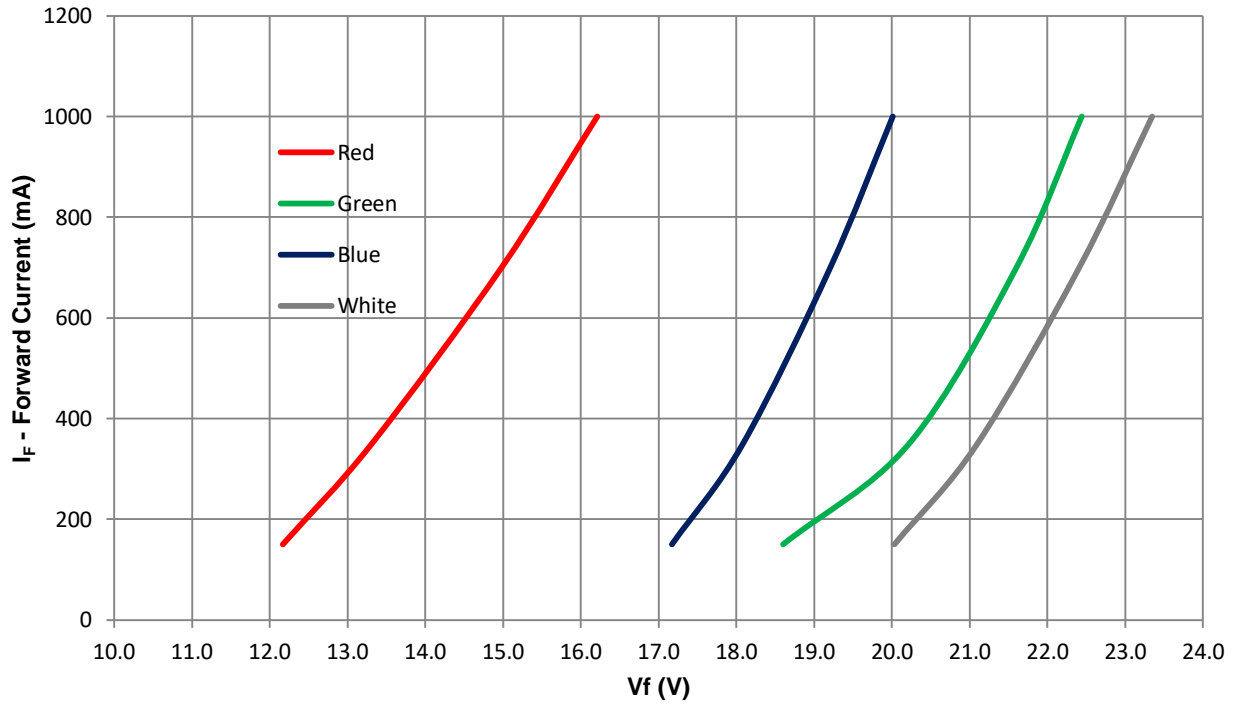

Figure 6: Typical forward current vs. forward voltage @ T_C = 25°C

Typical Relative Light Output over Current

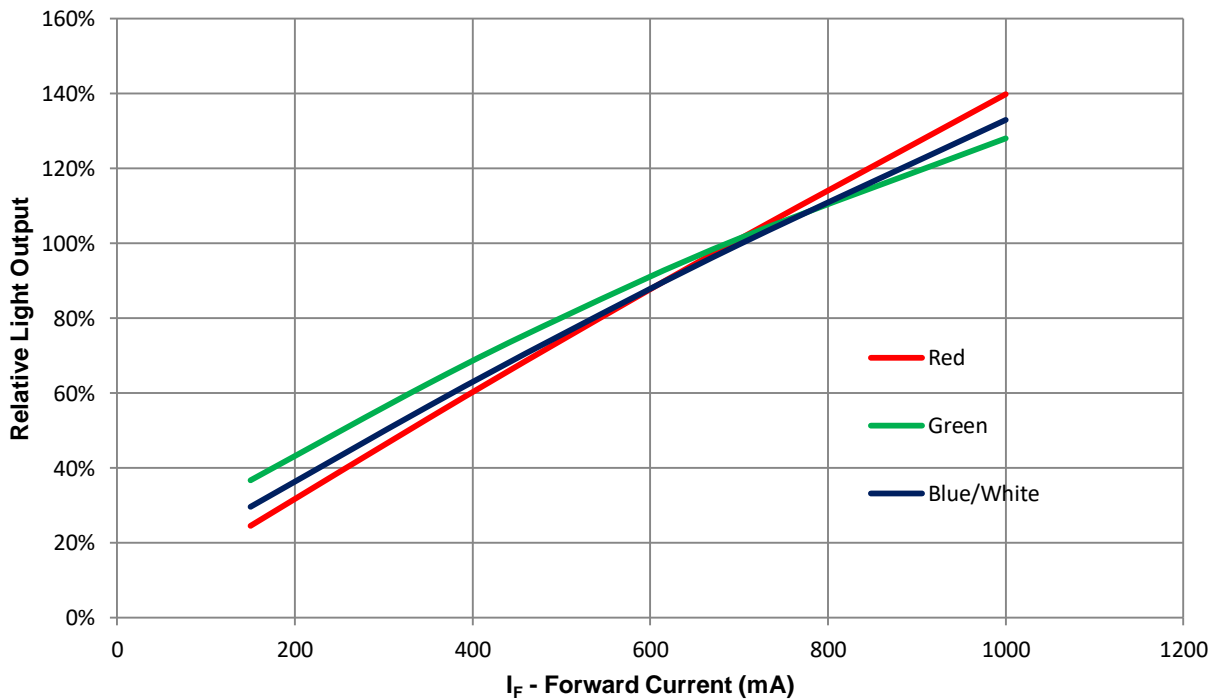

Figure 7: Typical relative light output vs. forward current @ T_C = 25°C

Typical Relative Light Output over Temperature

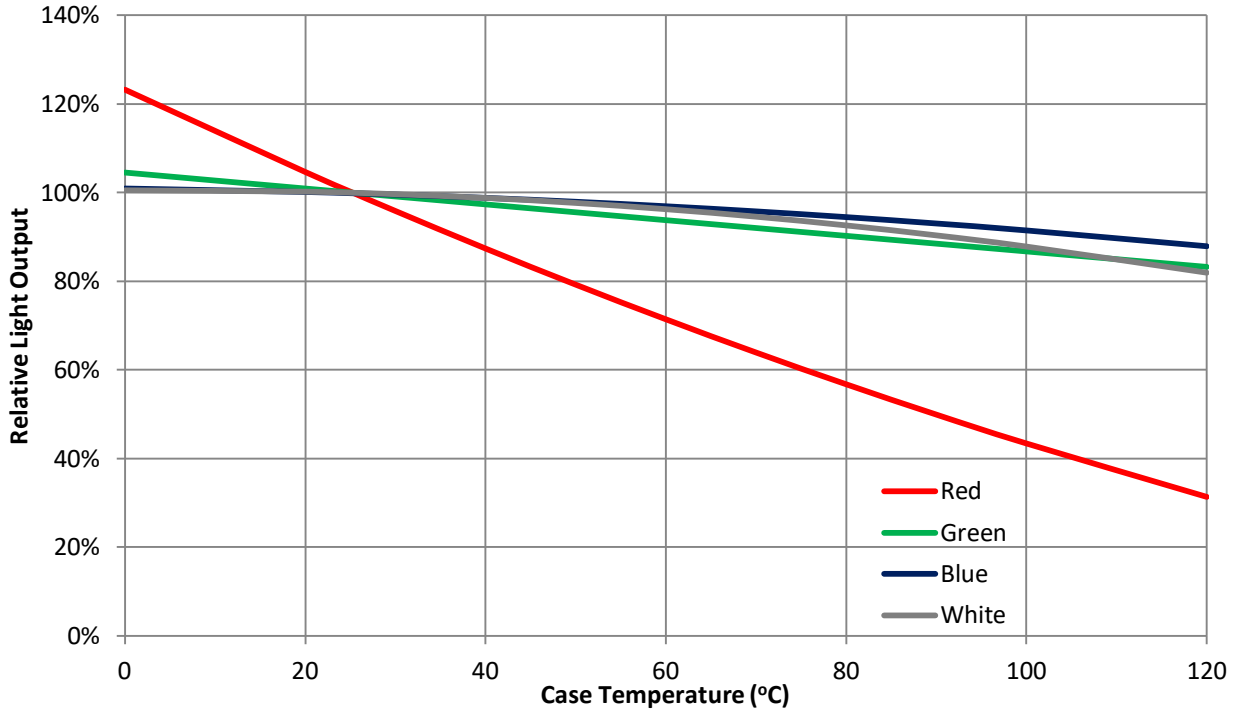

Figure 8: Typical relative light output vs. case temperature

Typical Dominant Wavelength/Chromaticity Coordinate Shift over Current

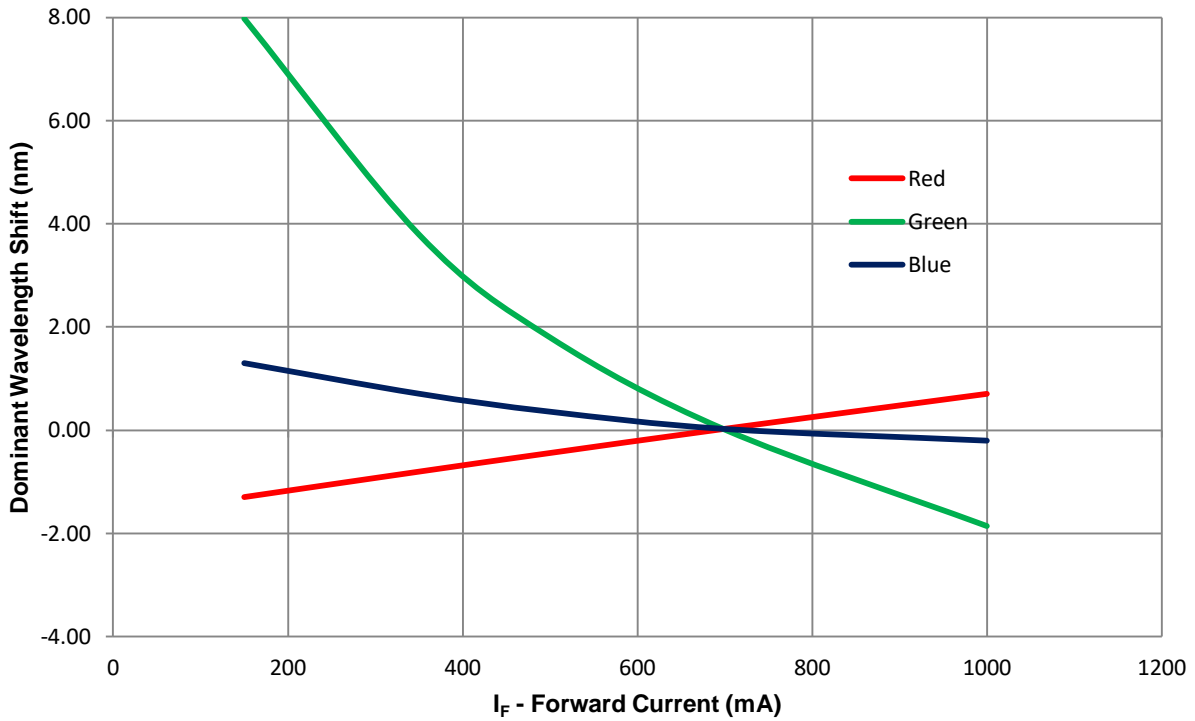

Figure 9a: Typical dominant wavelength shift vs. forward current @ T_C = 25°C

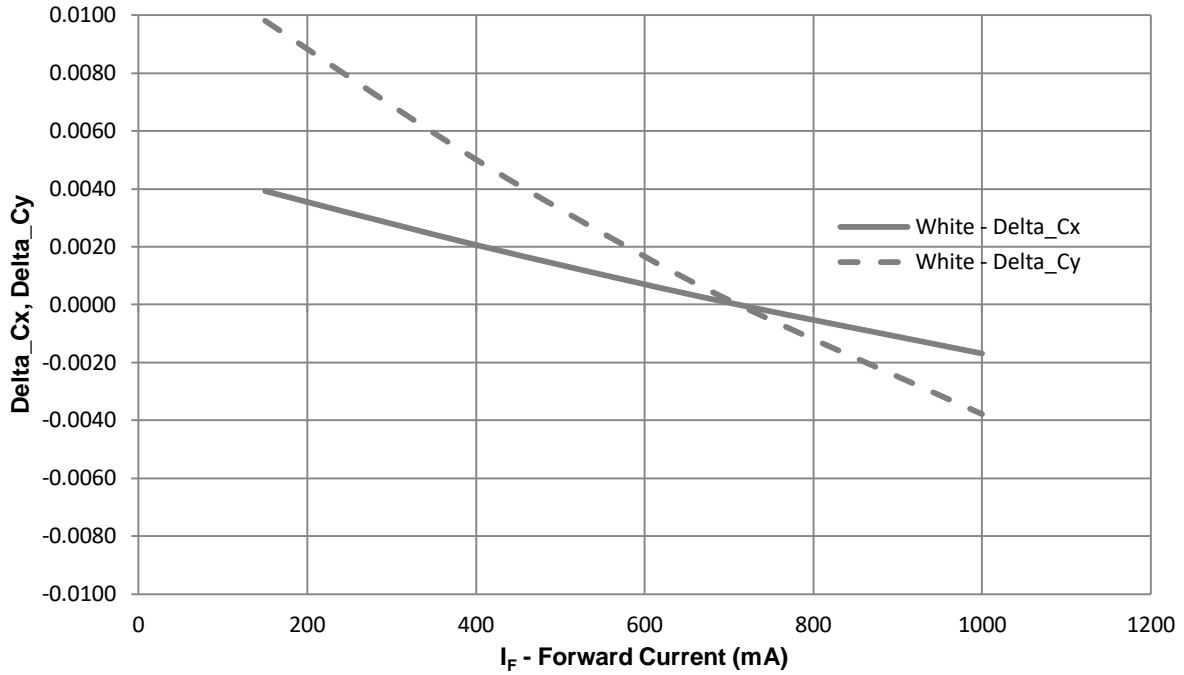

Figure 9b: Typical chromaticity coordinate shift vs. forward current @ TC = 25°C

Typical Dominant Wavelength/Chromaticity Coordinate Shift over Temperature

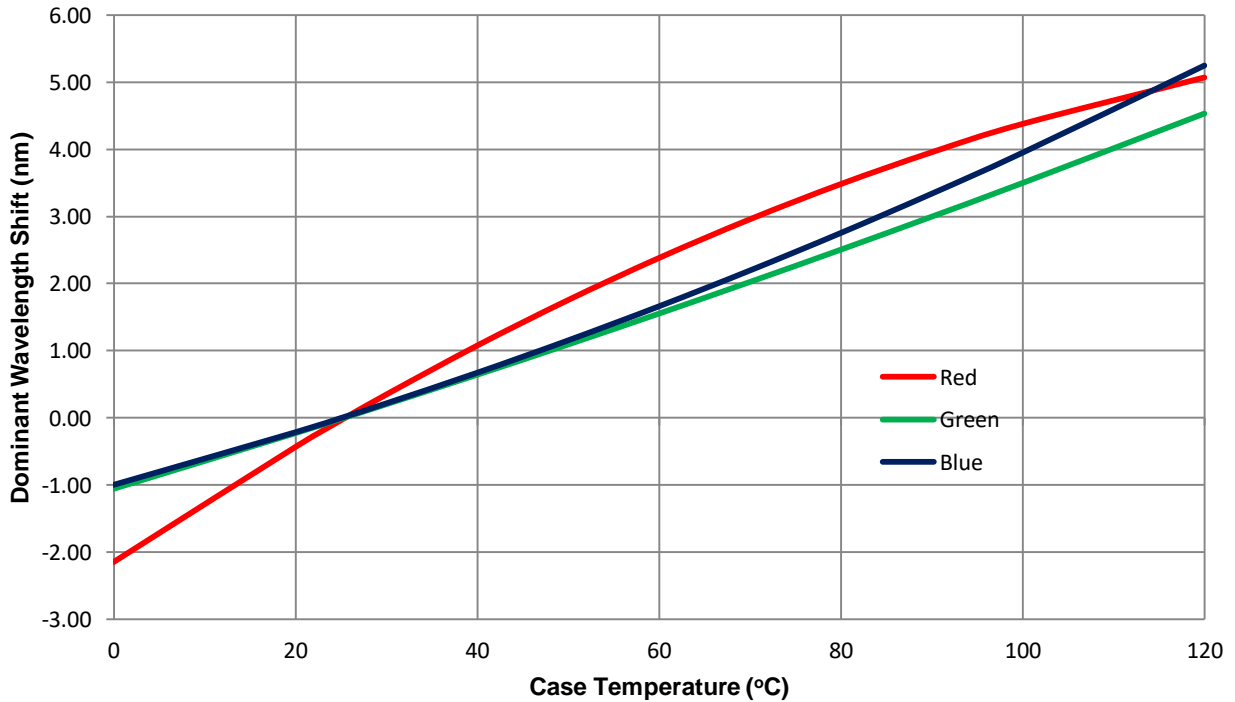

Figure 10a: Typical dominant wavelength shift vs. case temperature

LZP-04MD00

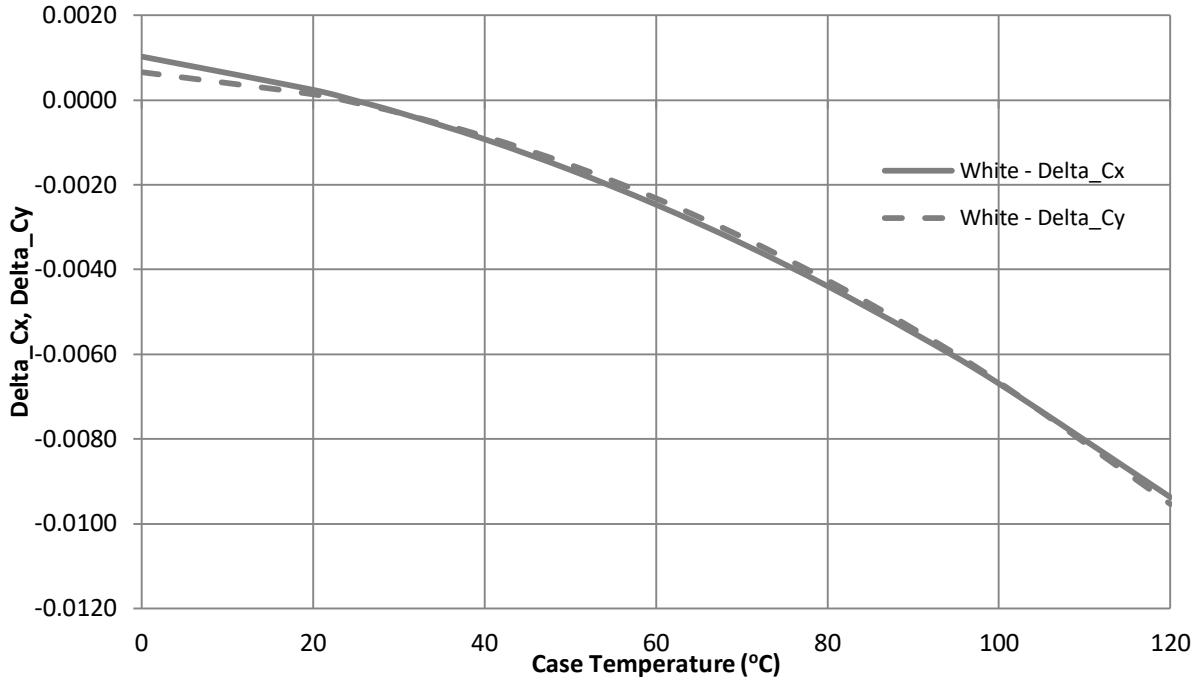

Figure 10b: Typical chromaticity coordinate shift vs. case temperature

Current De-rating

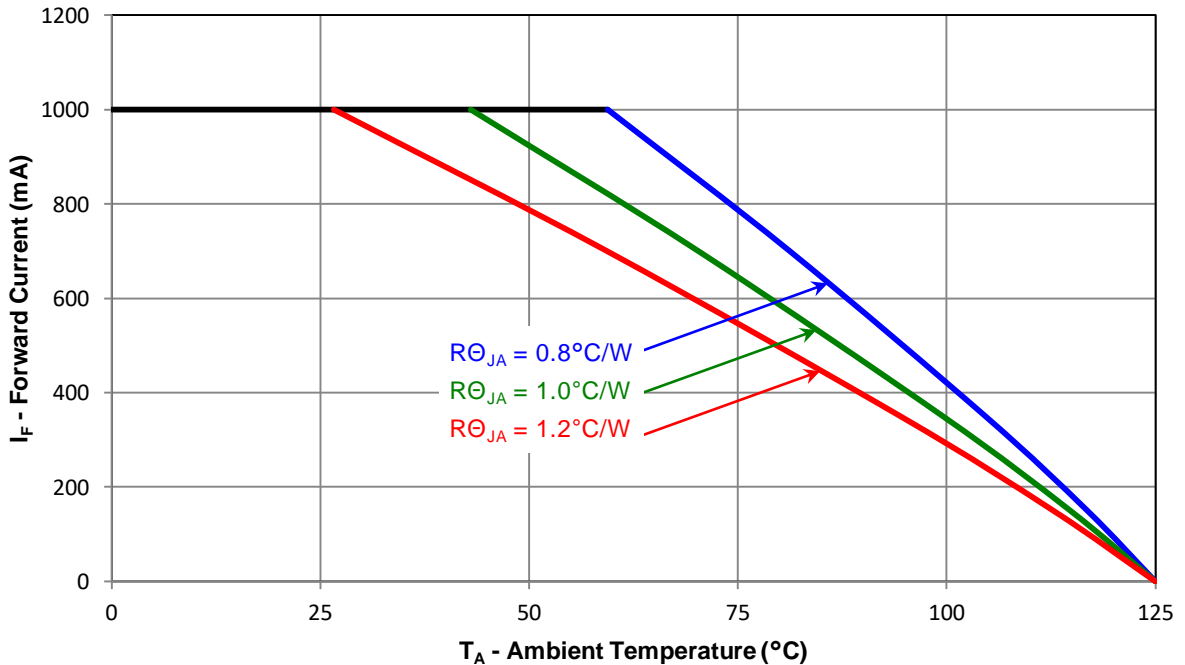

Figure 11: Maximum forward current vs. ambient temperature based on $T_{J(MAX)} = 125^{\circ}C$

Notes for Figure 11:

1. Maximum current assumes that all 25 LED dies are operating concurrently at the same current.
2. $R_{\Theta J-C}$ [Junction to Case Thermal Resistance] for LZP-04MD00 is typically $0.5^{\circ}C/W$.
3. $R_{\Theta J-A}$ [Junction to Ambient Thermal Resistance] = $R_{\Theta J-C} + R_{\Theta C-A}$ [Case to Ambient Thermal Resistance].

LZP MCPCB Option

Part number	Type of MCPCB	Dimension (mm)	Emitter + MCPCB Thermal Resistance ($^{\circ}\text{C}/\text{W}$)	Typical V_F (V)	Typical I_F (mA)
LZP-Lxxxxx	4-channel	28.3	$0.5 + 0.1 = 0.6$	15.0-22.4	4 x 700

4-Channel MCPCB Mechanical Dimensions (mm)

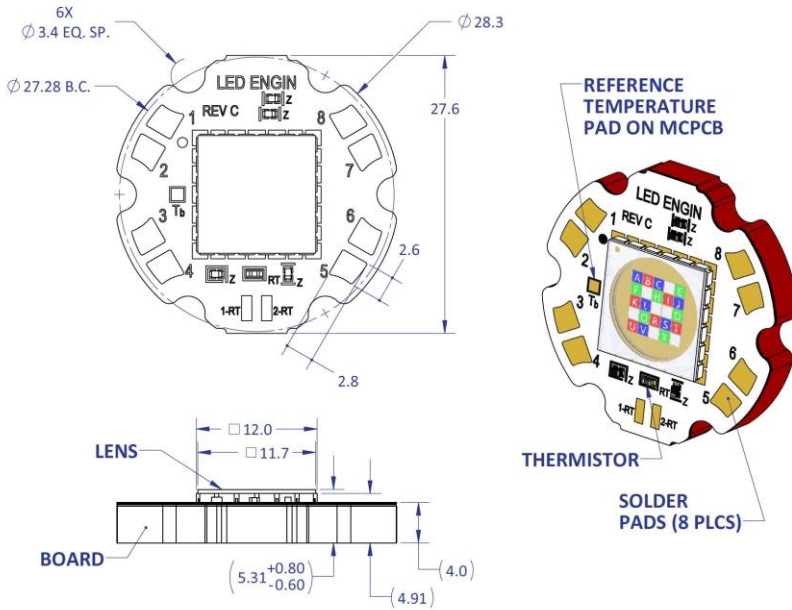

Notes:

1. Unless otherwise noted, the tolerance = ± 0.20 mm.
2. Slots in MCPCB are for M3 or #4-40 mounting screws.
3. The thermal resistance of the MCPCB is: RΘC-B 0.1°C/W.

Components used

- MCPCB: MHE-301 copper (Rayben)
 ESD chips: BZX884-B39 (NXP, for 6-7 LED dies in series)
 NTC: NCP15XH103F03RC (Murata)

Pad layout			
Ch.	MCPCB Pad	String/die	Function
1 (Red)	8	1/ BIKRTU	Anode +
	1		Cathode -
2 (Green)	7	2/ EFHOQX	Anode +
	2		Cathode -
3 (Blue)	6	3/ ACJLSV	Anode +
	3		Cathode -
4 (White)	5	4/ DGMNPWY	Anode +
	4		Cathode -
NTC	1-RT	10kohm	NTCA
	2-RT	NTC	NTCB

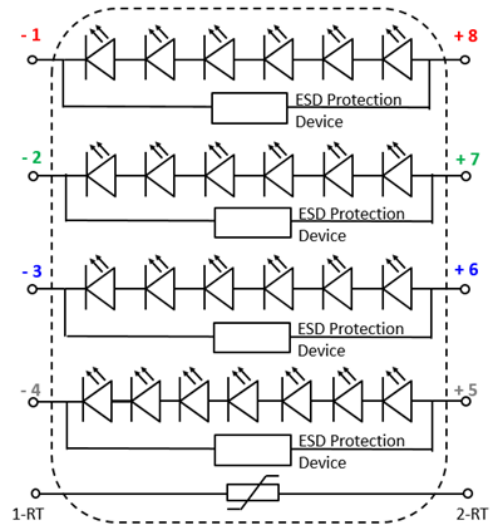

Application Guidelines

MCPCB Assembly Recommendations

A good thermal design requires an efficient heat transfer from the MCPCB to the heat sink. In order to minimize air gaps in between the MCPCB and the heat sink, it is common practice to use thermal interface materials such as thermal pastes, thermal pads, phase change materials and thermal epoxies. Each material has its pros and cons depending on the design. Thermal interface materials are most efficient when the mating surfaces of the MCPCB and the heat sink are flat and smooth. Rough and uneven surfaces may cause gaps with higher thermal resistances, increasing the overall thermal resistance of this interface. It is critical that the thermal resistance of the interface is low, allowing for an efficient heat transfer to the heat sink and keeping MCPCB temperatures low. When optimizing the thermal performance, attention must also be paid to the amount of stress that is applied on the MCPCB. Too much stress can cause the ceramic emitter to crack. To relax some of the stress, it is advisable to use plastic washers between the screw head and the MCPCB and to follow the torque range listed below. For applications where the heat sink temperature can be above 50°C, it is recommended to use high temperature and rigid plastic washers, such as polycarbonate or glass-filled nylon.

LED Engin recommends the use of the following thermal interface materials:

- Bergquist's Gap Pad 5000S35, 0.020in thick
 - Part Number: Gap Pad® 5000S35 0.020in/0.508mm
 - Thickness: 0.020in/0.508mm
 - Thermal conductivity: 5 W/m-K
 - Continuous use max temperature: 200°C
 - Using M3 Screw (or #4 screw), with polycarbonate or glass-filled nylon washer (#4) the recommended torque range is: 20 to 25 oz-in (1.25 to 1.56 lbf-in or 0.14 to 0.18 N-m)

- 3M's Acrylic Interface Pad 5590H
 - Part number: 5590H @ 0.5mm
 - Thickness: 0.020in/0.508mm
 - Thermal conductivity: 3 W/m-K
 - Continuous use max temperature: 100°C
 - Using M3 Screw (or #4 screw), with polycarbonate or glass-filled nylon washer (#4) the recommended torque range is: 20 to 25 oz-in (1.25 to 1.56 lbf-in or 0.14 to 0.18 N-m)

Mechanical Mounting Considerations

The mounting of MCPCB assembly is a critical process step. Excessive mechanical stress build up in the MCPCB can cause the MCPCB to warp which can lead to emitter substrate cracking and subsequent cracking of the LED dies.

LED Engin recommends the following steps to avoid mechanical stress build up in the MCPCB:

- Inspect MCPCB and heat sink for flatness and smoothness.
- Select appropriate torque for mounting screws. Screw torque depends on the MCPCB mounting method (thermal interface materials, screws, and washer).
- Always use three M3 or #4-40 screws with #4 washers.
- When fastening the three screws, it is recommended to tighten the screws in multiple small steps. This method avoids building stress by tilting the MCPCB when one screw is tightened in a single step.
- Always use plastic washers in combinations with the three screws. This avoids high point contact stress on the screw head to MCPCB interface, in case the screw is not seated perpendicular.
- In designs with non-tapped holes using self-tapping screws, it is common practice to follow a method of three turns tapping a hole clockwise, followed by half a turn anti-clockwise, until the appropriate torque is reached.

Wire Soldering

- To ease soldering wire to MCPCB process, it is advised to preheat the MCPCB on a hot plate of 125-150°C. Subsequently, apply the solder and additional heat from the solder iron will initiate a good solder reflow. It is recommended to use a solder iron of more than 60W.
- It is advised to use lead-free, no-clean solder. For example: SN-96.5 AG-3.0 CU 0.5 #58/275 from Kester (pn: 24-7068-7601)

LZP-04MD00

About LED Engin

LED Engin, an OSRAM brand based in California's Silicon Valley, develops, manufactures, and sells advanced LED emitters, optics and light engines to create uncompromised lighting experiences for a wide range of entertainment, architectural, general lighting and specialty applications. LuxiGen™ multi-die emitter and secondary lens combinations reliably deliver industry-leading flux density, upwards of 5000 quality lumens to a target, in a wide spectrum of colors including whites, tunable whites, multi-color and UV LEDs in a unique patented compact ceramic package. Our LuxiTune™ series of tunable white lighting modules leverage our LuxiGen emitters and lenses to deliver quality, control, freedom and high density tunable white light solutions for a broad range of new recessed and downlighting applications. The small size, yet remarkably powerful beam output and superior in-source color mixing, allows for a previously unobtainable freedom of design wherever high-flux density, directional light is required. LED Engin is committed to providing products that conserve natural resources and reduce greenhouse emissions; and reserves the right to make changes to improve performance without notice.

For more information, please contact LEDE-Sales@osram.com or +1 408 922-7200.

LED Engin office:
651 River Oaks Parkway
San Jose, CA 95134
USA
408 922-7200
LEDE-Sales@osram.com
www.osram.us/ledengin

Our Brand

LED ENGIN

OSRAM