

PART NUMBER	REVISION	DESCRIPTION	FEED TYPE
2150247-1	F	FINE CRIMP HEIGHT ADJUST	MECHANICAL
2150247-2	G	FINE CRIMP HEIGHT ADJUST	PNEUMATIC
7-2150247-1	F	MECHANICAL AND CRIMP TOOLING KIT	MECHANICAL
7-2150247-2	G	PNEUMATIC AND CRIMP TOOLING KIT	PNEUMATIC
7-2150247-7	D	CRIMP TOOLING KIT	-

ATLANTIC VERSION TERMINATOR INTERFACE ADAPTER

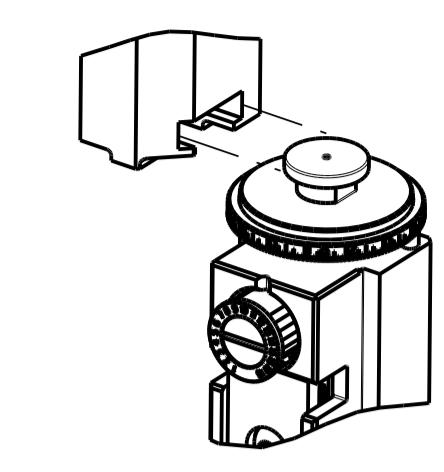

APPLICATOR DATA		
CRIMP	SIZE	TYPE
WIRE	3.05 mm [.120]	F
INSUL	6.35 mm [.250]	F

APPLICATOR INSTRUCTIONS
408-35043

TERMINAL DATA: TE TERMINAL		TE CRIMP SPECIFICATION	
TERMINAL NAME: .250 SERIES FASTIN-FASTON RECEPTACLE			
WIRE STRIP LENGTH		INSULATION DIAMETER RANGE	
4.72-5.48 mm [.186-.216 IN]		Ø4.06-5.33 mm [.160-.210 IN]	
TERMINAL APPLICATION SPECIFICATION	(A)114-2025		
	(B)114-2036		
TERMINALS APPLIED			
TE TERMINAL	TE TERMINAL	TE TERMINAL	TE TERMINAL
(A) 60249-1	(A) 60249-2	(A) 60249-3	(B) 63896-1

WIRE SIZE	CRIMP HEIGHT mm [INCH]	CRIMP HEIGHT REFERENCE SETTING
12 AWG	2.18+/-0.05 [.086+/-0.002]	4.3
2x16 AWG	2.03+/-0.05 [.080+/-0.002]	6.8
14 AWG	1.85+/-0.05 [.073+/-0.002]	8.1
16 AWG	1.65+/-0.05 [.065+/-0.002]	10.4

- RECOMMENDED SPARE PARTS
- REFER TO SUPPLIED INSTRUCTION SHEET FOR CLEANING, LUBRICATION AND STORAGE OF APPLICATOR.
- APPLY PART NUMBER 2-23419-6 LOCTITE TO THREADS OF ITEM 242. APPLY PART NUMBER 1-23419-5 LOCTITE TO THREADS OF ITEM 180.
- CRIMP HEIGHT REFERENCE SETTING WAS THE SETTING USED WHEN THE APPLICATOR WAS QUALIFIED AT THE FACTORY. ADJUSTMENT MAY BE NECESSARY WHEN RUNNING APPLICATOR IN THE FIELD.
- TERMINAL LUBRICANT IS RECOMMENDED.
- 6. UNLESS SPECIFIED OTHERWISE TORQUE VALUES SHALL BE USED PER DOCUMENT, 101-35000.

***WARNING**
ON INSTALLATION, SET WIRE DISC TO CRIMP HEIGHT REFERENCE SETTING FOR LARGEST WIRE SIZE. CRIMP HEIGHT REFERENCE SETTINGS GREATER THAN THE VALUE SHOWN MAY CAUSE DAMAGE TO THE CRIMP TOOLING, REFER TO THE INSTRUCTION SHEET FOR PROPER SETUP AND ADJUSTMENTS.

ATLANTIC VERSION
Shown on sheets 1 of 4 & 2 of 4
(Pacific version shown on sheets 3 of 4 & 4 of 4)

LOC	DIST	REV	DATE	BY	CHKD	APP'D
A	66	F	05MAR2018	FL	JD	
		E	30SEP2018	TB	TE	
		F	12JUN2019	MZ	TE	
		G	14DEC2020	FZ	TE	

-	1	-	1	-	2119641-1	FEED CAM, AIR FEED	248
-	1	1	1	1	2119082-9	CAM, SNAIL, INSULATION ADJUSTMENT	244
-	1	1	1	1	2079764-1	WASHER, WAVE SPRING, CREST-TO-CREST	243
	-	1	1	1	2119083-1	RETAINER, INSULATION DIAL	242
-	-	1	-	1	2119580-1	MECHANICAL FEED ASSEMBLY	239
-	1	-	1	-	2844940-3	AIR FEED MODULE	238
-	1	1	1	1	1-18028-0	WASHER, FLAT, REG M8	192
	-	1	1	1	1-1976055-1	STANDOFF, HOLD-DOWN	180
-	1	1	1	1	6-993111-6	PIN, SLOTTED SPRING 3.0 X 14.0	177
-	1	1	1	1	8-22280-7	SPRING, COMPRESSION	176
-	1	1	1	1	1752353-2	GUIDE PIN,HOLDDOWN	175
-	1	1	1	1	1901680-2	GUIDE PIN,HOLDDOWN	174
-	REF	REF	REF	REF	994970-2	COUNTER, MAGNETIC	164
	-	1	1	1	2119955-2	ASSY, LUBRICATOR, END FEED	84
-	1	1	1	1	1-455888-2	SPACER, CRIMPER	82
-	1	1	1	1	2119791-5	DEPRESSOR, WIRE	73
-	1	1	1	1	1803607-4	DOCUMENTATION PACKAGE	71
-	2	2	2	2	2-18032-2	SCR, SET, FLT PNT, M3 X 10.0	70
-	1	1	1	1	2119943-1	WASHER, SPACER	69
-	1	1	1	1	2119740-1	TAG, IDENTIFICATION	67
-	2	2	2	2	2168078-1	SCREW, DRIVE, RH, RoHS, 2 x .188	66
-	1	1	1	1	1901681-1	HOLDDOWN, TERMINAL	65
-	2	2	2	2	2168400-5	SHCS, LOW HEAD, RoHS, M4 X 20	64
-	1	1	1	1	2168083-2	SCR, SKT HD CAP, RoHS, M4 X 8.0	60
-	1	1	1	1	5-18022-5	SCR, HEX HD CAP, M4 X 6.0	59
-	-	1	-	1	2063961-1	FEED FINGER	58
-	3	3	3	3	2168400-4	SHCS, LOW HEAD, RoHS, M4 X 8	57
-	2	2	2	2	1-2168083-0	SCR, SKT HD CAP, RoHS, M4 X 10	56
-	2	2	2	2	5018030-1	NUT, HEX, REG, RoHS, M3	54
-	2	2	2	2	986965-8	NUT, LOCK, HEX, TORQUE (M4)	53
-	1	1	1	1	1-5018030-0	NUT, HEX, REG, RoHS, M3.5	52
-	1	-	1	-	2063961-1	FEED FINGER	51
-	1	2	1	2	18023-9	SCR, SKT HD CAP M4 X 6.0	49
-	-	1	-	1	2119652-1	FEED CAM, PRE FEED	48
-	-	1	-	1	2119653-1	FEED CAM, POST FEED	47
-	1	1	1	1	2119655-5	APPLICATOR BASIC ASSEMBLY, EF	46
-	1	1	1	1	1803517-1	RAM ASSEMBLY, EF ATLANTIC	44
-	1	1	1	1	1803602-1	SCR, BHSC, RoHS (M8 X 25)	41
-	7	7	7	7	1-18028-2	WASHER, FLAT, REG M4	33
-	2	2	2	2	2079383-5	SCR, BHSC, RoHS (M4 X 20)	31
-	2	2	2	2	2168083-2	SCR, SKT HD CAP, RoHS, M4 X 8.0	29
-	1	1	1	1	240639-1	STRIPPER (MACHINING)	27
-	2	2	2	2	1-2168083-5	SCR, SKT HD CAP, RoHS, M4 X 30	25
-	1	1	1	1	1752371-3	PLATE, STRIP GUIDE	24
-	1	1	1	1	240825-3	PLATE, STRIP HOLD DOWN	23
-	2	2	2	2	2-22281-3	SPRING, COMPRESSION	22
-	1	1	1	1	1803292-4	DRAG	20
-	2	2	2	2	1901259-6	GUIDE, LOWER STRIP	18
-	4	4	4	4	1-2079383-1	SCR, BHSC, RoHS (M6 X 12)	17
-	1	1	1	1	8-240641-6	SPACER	16
-	1	1	1	1	1752360-1	SPACER,HOLD-DOWN	13
	-	1	1	1	240833-2	PLATE, REAR SHEAR	11
-	-	-	-	-	-	-	10
	-	1	1	1	690496-4	PLATE, FRONT SHEAR	9
	1	2	2	1	1803000-6	ANVIL, COMBINATION, END FEED	8
	-	1	1	1	1-2217206-3	BLADE, SLUG	7
-	1	1	1	1	1-240641-6	SPACER	5
-	1	1	1	1	238011-2	BLOCK, CRIMPER SPACER	4
	1	2	2	1	2-1633961-5	CRIMPER, INSULATION F PREMIUM	3
-	1	1	1	1	455888-1	SPACER, CRIMPER	2
	1	2	2	1	456423-2	CRIMPER, WIRE PREMIUM	1
-	77	72	71	2	-1	PART NO	ITEM NO

DIMENSIONS: mm		TOLERANCES UNLESS OTHERWISE SPECIFIED:		DWG: HOFFNER 1FEB2012		TE Connectivity Harrisburg, PA 17105-3608	
0 PLC ±		1 PLC ±		CHK: TELBIN 8FEB2012		NAME: Ocean End Feed Applicator	
2 PLC ±		3 PLC ±		APP'D: TELBIN 8FEB2012		SIZE: CAGE CODE: DRAWING NO: RESTRICTED TO	
4 PLC ±		ANGLES ±		PRODUCT SPEC		00779 ©=2150247	
MATERIAL:		FINISH:		APPLICATION SPEC		WEIGHT: A1 00779 ©=2150247	
Customer Accessible Production Drawing				SCALE: 1:1		SHEET 1 OF 4 REV G	

LOC	DIST	REV	DATE	BY	APPV
A	66				
REVISIONS			DESCRIPTION	DATE	BY
			SEE SHEET 1		

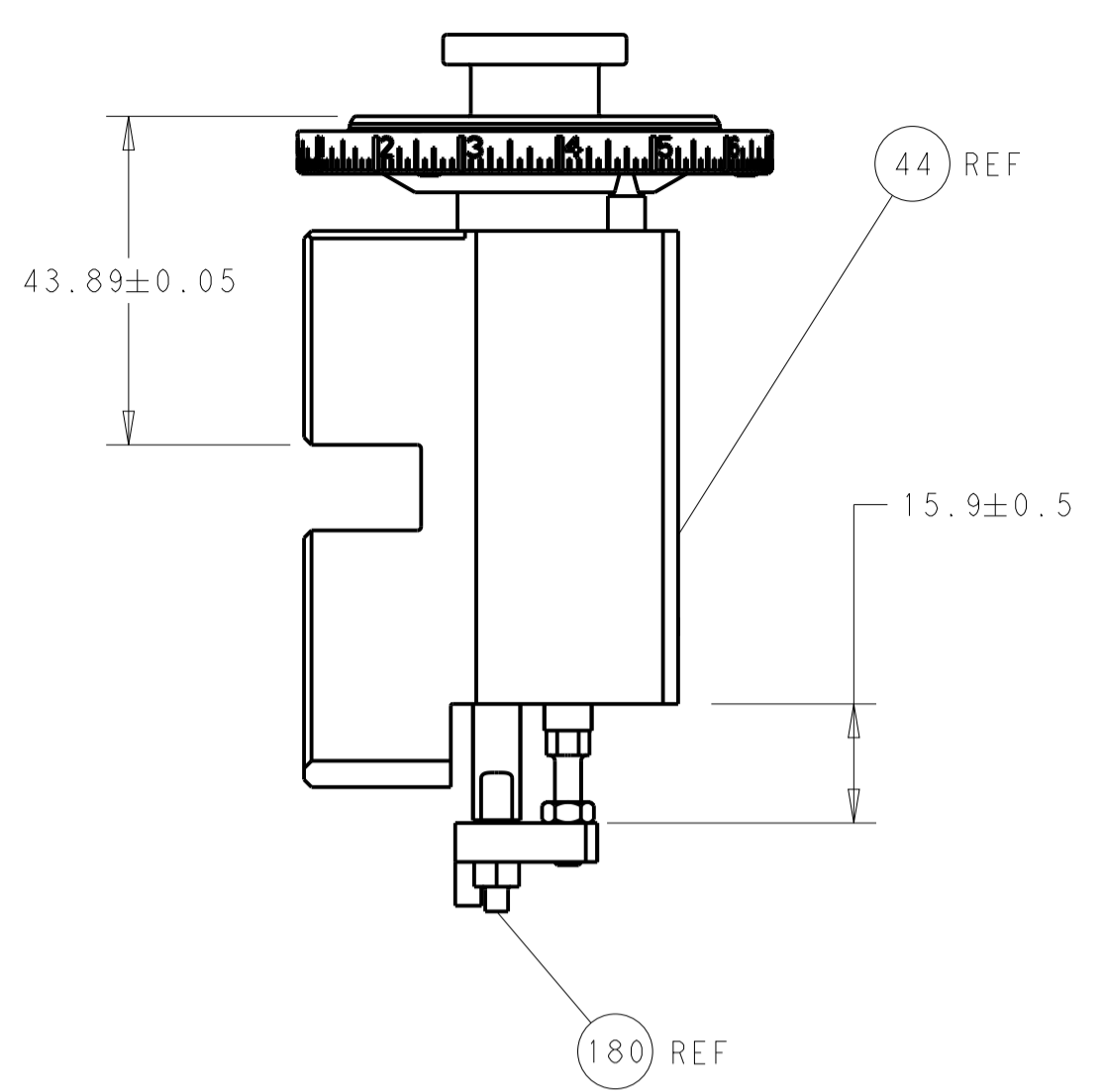

RAM AND HOLDDOWN SET-UP

FEED TYPE
MECHANICAL

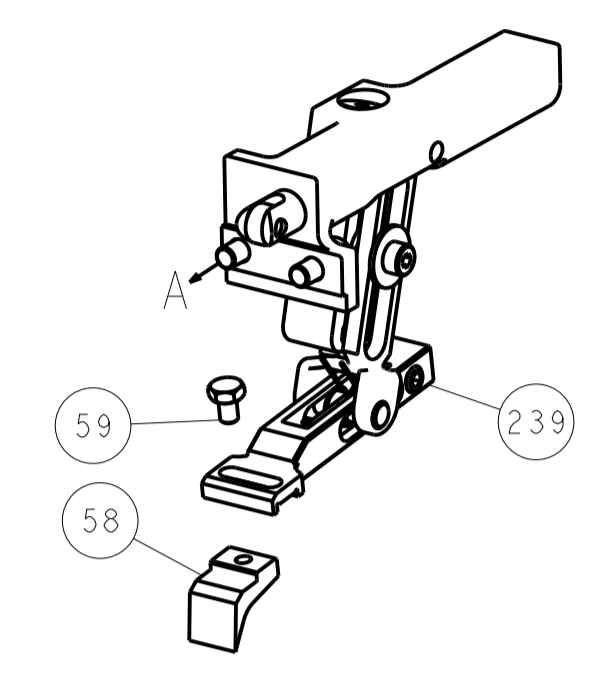

PNEUMATIC

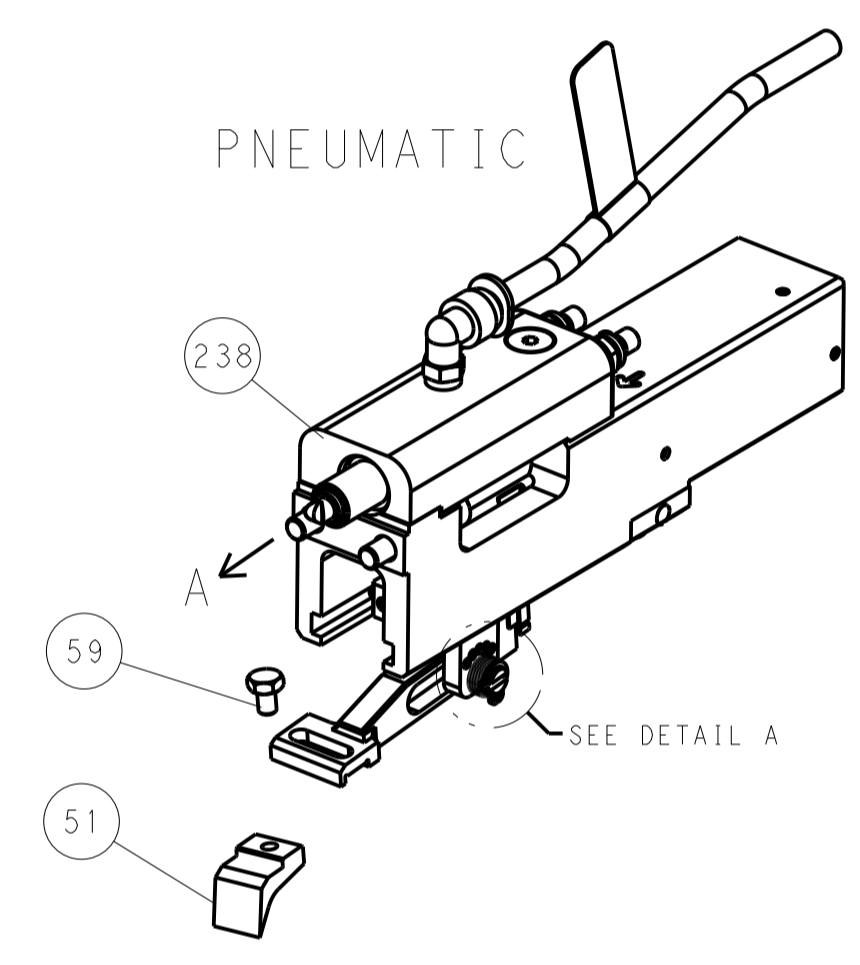

FEED SPRING
SETTING POSITION

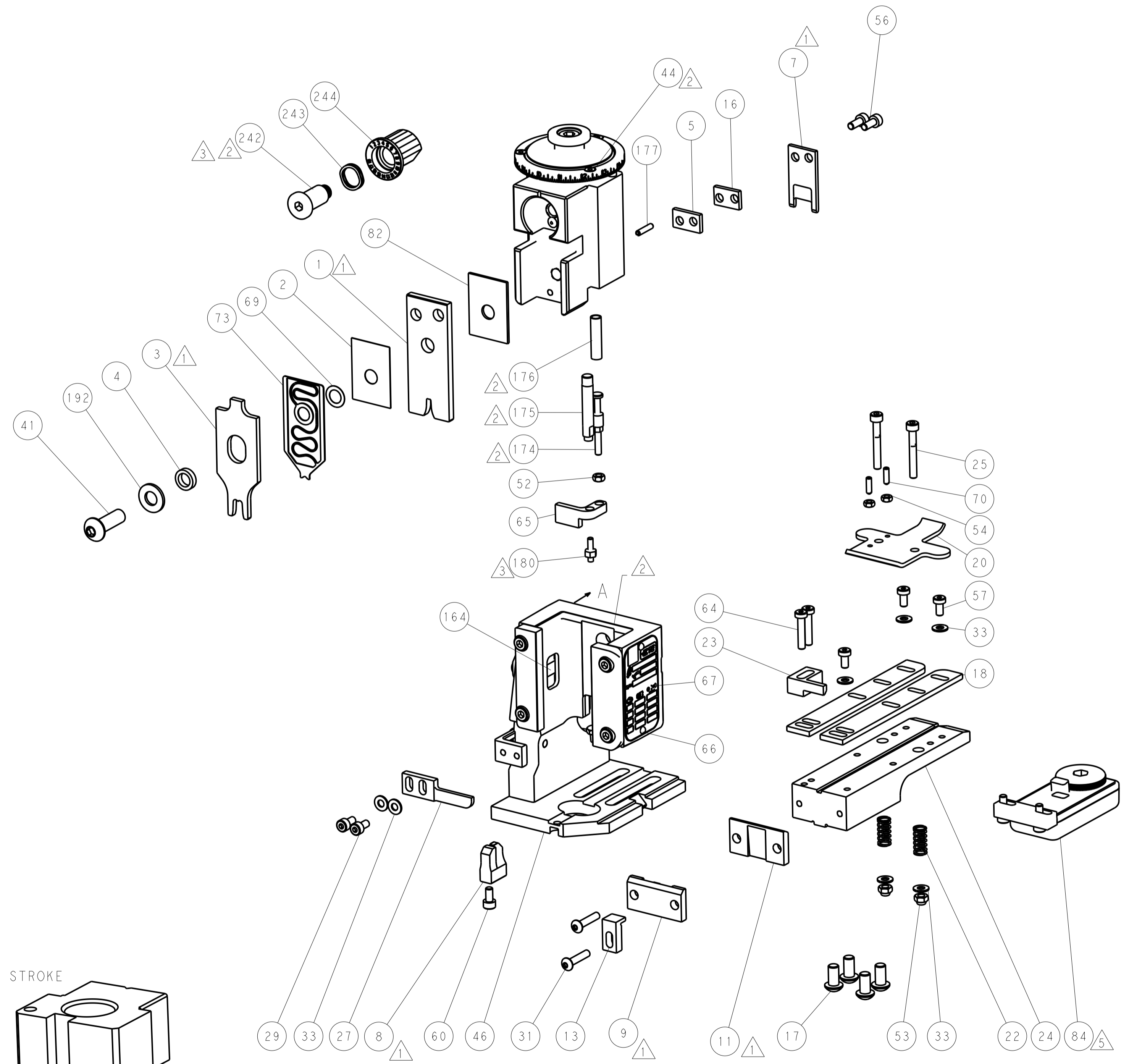
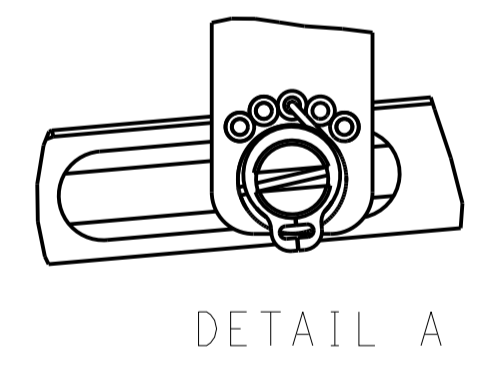

CAM POSITIONS

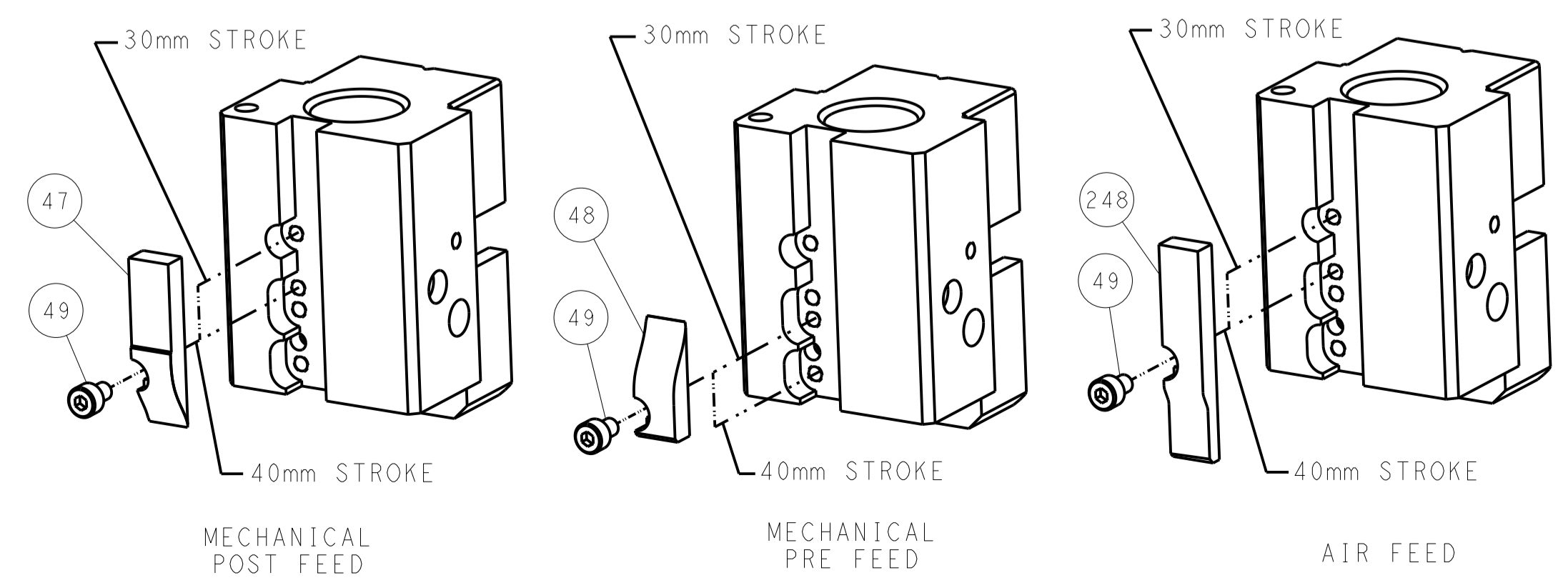

ATLANTIC VERSION
Shown on sheets 1 of 4 & 2 of 4
(Pacific version shown on sheets 3 of 4 & 4 of 4)

DIMENSIONS:		TOLERANCES UNLESS OTHERWISE SPECIFIED:		DWG: HOFFNER 7FEB2012		TE Connectivity	
mm	0 PLC ±	1 PLC ±	2 PLC ±	3 PLC ±	4 PLC ±	5 PLC ±	Harrisburg, PA 17105-3608
MATERIAL:		FINISH:		DWG: T.ELBIN 8FEB2012		NAME: Ocean End Feed Applicator	
				PRODUCT SPEC:		SIZE: A	
				APPLICATION SPEC:		CAGE CODE: 00779	
				WEIGHT:		DRAWING NO: 2150247	
				Customer Accessible Production Drawing		SCALE: 1:1 SHEET 2 OF 4 REV G	

PART NUMBER	REVISION	DESCRIPTION	FEED TYPE
2-2150247-1	F	FINE CRIMP HEIGHT ADJUST	MECHANICAL
2-2150247-2	G	FINE CRIMP HEIGHT ADJUST	PNEUMATIC
7-2150247-7	D	CRIMP TOOLING KIT	-

PACIFIC VERSION TERMINATOR
INTERFACE ADAPTER

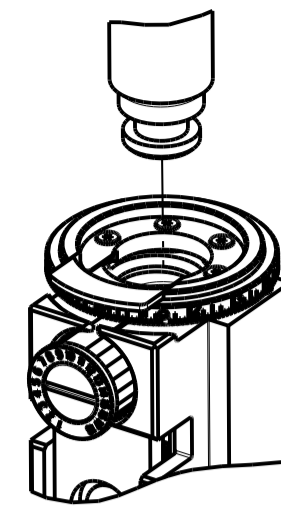

APPLICATOR DATA		
CRIMP	SIZE	TYPE
WIRE	3.05 mm [1.20]	F
INSUL	6.35 mm [2.50]	F
APPLICATOR INSTRUCTIONS 408-35043		

TERMINAL DATA: TE TERMINAL		TE CRIMP SPECIFICATION	
TERMINAL NAME: .250 SERIES FASTIN-FASTON RECEPTACLE			
WIRE STRIP LENGTH 4.72-5.48 mm [1.86-.216 IN]		INSULATION DIAMETER RANGE 4.06-5.33 mm [1.60-.210 IN]	
TERMINAL APPLICATION SPECIFICATION	(A)114-2025	-	-
	(B)114-2036	-	-
TERMINALS APPLIED			
TE TERMINAL	TE TERMINAL	TE TERMINAL	TE TERMINAL
(A) 60249-1	(A) 60249-2	(A) 60249-3	(B) 63896-1

WIRE SIZE	CRIMP HEIGHT mm [INCH]	CRIMP HEIGHT REFERENCE SETTING
12 AWG	2.18 +/- 0.05 [1.086 +/- .002]	4.3
2x16 AWG	2.03 +/- 0.05 [1.080 +/- .002]	6.8
14 AWG	1.85 +/- 0.05 [1.073 +/- .002]	8.1
16 AWG	1.65 +/- 0.05 [1.065 +/- .002]	10.4

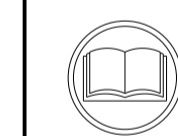

- 1. RECOMMENDED SPARE PARTS
- 2. REFER TO SUPPLIED INSTRUCTION SHEET FOR CLEANING, LUBRICATION AND STORAGE OF APPLICATOR.
- 3. APPLY PART NUMBER 2-23419-6 LOCTITE TO THREADS OF ITEM 242. APPLY PART NUMBER 1-23419-5 LOCTITE TO THREADS OF ITEM 180.
- 4. CRIMP HEIGHT REFERENCE SETTING WAS THE SETTING USED WHEN THE APPLICATOR WAS QUALIFIED AT THE FACTORY. ADJUSTMENT MAY BE NECESSARY WHEN RUNNING APPLICATOR IN THE FIELD.
- 5. TERMINAL LUBRICANT IS RECOMMENDED.
- 6. UNLESS SPECIFIED OTHERWISE TORQUE VALUES SHALL BE USED PER DOCUMENT, 101-35000.

***WARNING**
ON INSTALLATION, SET WIRE DISC TO CRIMP HEIGHT REFERENCE SETTING FOR LARGEST WIRE SIZE. CRIMP HEIGHT REFERENCE SETTINGS GREATER THAN THE VALUE SHOWN MAY CAUSE DAMAGE TO THE CRIMP TOOLING, REFER TO THE INSTRUCTION SHEET FOR PROPER SETUP AND ADJUSTMENTS.

PACIFIC VERSION
Shown on sheets 3 of 4 & 4 of 4
(Atlantic version shown on sheets 1 of 4 & 2 of 4)

LOC	DIST	REV	DATE	BY	CHKD	APPD
A	66					

REVISIONS						
REV	DATE	BY	CHKD	APPD	DESCRIPTION	QTY
-	-	-	-	-	SEE SHEET 1	-
-	1	1			2119082-9 CAM, SNAIL, INSULATION ADJUSTMENT	244
-	1	1			2079764-1 WASHER, WAVE SPRING, CREST-TO-CREST	243
-	1	1			2119083-1 RETAINER, INSULATION DIAL	242
-	-	1			2119580-1 MECHANICAL FEED ASSEMBLY	239
-	1	-			2844940-3 AIR FEED MODULE	238
-	1	1			1-18028-0 WASHER, FLAT, REG M8	192
-	4	4			2079383-9 SCR, BHSC, RoHS (M6 X 20)	186
-	1	1			1-1976055-1 STANDOFF, HOLD-DOWN	180
-	1	1			6-993111-6 PIN, SLOTTED SPRING 3.0 X 14.0	177
-	1	1			8-22280-7 SPRING, COMPRESSION	176
-	1	1			1752353-2 GUIDE PIN, HOLDDOWN	175
-	1	1			1901680-2 GUIDE PIN, HOLDDOWN	174
-	REF	REF			994970-2 COUNTER, MAGNETIC	164
-	1	-			2119641-2 FEED CAM, AIR FEED	152
-	1	1			2168083-8 SCR, SKT HD CAP, RoHS, M4 X 16	144
-	-	1			2119653-2 FEED CAM, POST FEED	142
-	1	1			2119655-6 APPLICATOR BASIC ASSEMBLY, EF	141
-	1	1			1803518-1 RAM ASSEMBLY, EF PACIFIC	140
-	1	1			2119955-2 ASSY, LUBRICATOR, END FEED	84
-	1	1			1-455888-2 SPACER, CRIMPER	82
-	1	1			2119791-5 DEPRESSOR, WIRE	73
-	1	1			1803607-4 DOCUMENTATION PACKAGE	71
-	2	2			2-18032-2 SCR, SET, FLT PNT, M3 X 10.0	70
-	1	1			2119943-1 WASHER, SPACER	69
-	1	1			2119740-1 TAG, IDENTIFICATION	67
-	2	2			2168078-1 SCREW, DRIVE, RH, RoHS, 2 x .188	66
-	1	1			1901681-1 HOLDDOWN, TERMINAL	65
-	2	2			2168400-5 SHCS, LOW HEAD, RoHS, M4 X 20	64
-	1	1			5-18022-5 SCR, HEX HD CAP, M4 X 6.0	59
-	-	1			2063961-1 FEED FINGER	58
-	3	3			2168400-4 SHCS, LOW HEAD, RoHS, M4 X 8	57
-	2	2			1-2168083-0 SCR, SKT HD CAP, RoHS, M4 X 10	56
-	2	2			5018030-1 NUT, HEX, REG, RoHS, M3	54
-	2	2			986965-8 NUT, LOCK, HEX, TORQUE (M4)	53
-	1	1			1-5018030-0 NUT, HEX, REG, RoHS, M3.5	52
-	1	-			2063961-1 FEED FINGER	51
-	1	2			18023-9 SCR, SKT HD CAP M4 X 6.0	49
-	-	1			2119652-1 FEED CAM, PRE FEED	48
-	1	1			1803602-1 SCR, BHSC, RoHS (M8 X 25)	41
-	7	7			1-18028-2 WASHER, FLAT, REG M4	33
-	2	2			2079383-5 SCR, BHSC, RoHS (M4 X 20)	31
-	2	2			2168083-2 SCR, SKT HD CAP, RoHS, M4 X 8.0	29
-	1	1			240639-1 STRIPPER (MACHINING)	27
-	2	2			1-2168083-5 SCR, SKT HD CAP, RoHS, M4 X 30	25
-	1	1			1752371-3 PLATE, STRIP GUIDE	24
-	1	1			240825-3 PLATE, STRIP HOLD DOWN	23
-	2	2			2-22281-3 SPRING, COMPRESSION	22
-	1	1			1803292-4 DRAG	20
-	2	2			1901259-6 GUIDE, LOWER STRIP	18
-	1	1			8-240641-6 SPACER	16
-	1	1			1752360-1 SPACER, HOLD-DOWN	13
-	1	1			240833-2 PLATE, REAR SHEAR	11
-	-	-			-	10
-	1	1			690496-4 PLATE, FRONT SHEAR	9
-	1	1			1803000-6 ANVIL, COMBINATION, END FEED	8
-	1	1			1-2217206-3 BLADE, SLUG	7
-	1	1			1-240641-6 SPACER	5
-	1	1			238011-2 BLOCK, CRIMPER SPACER	4
-	1	1			2-1633961-5 CRIMPER, INSULATION F PREMIUM	3
-	1	1			455888-1 SPACER, CRIMPER	2
-	1	1			456423-2 CRIMPER, WIRE PREMIUM	1
-	77-22-21				PART NO DESCRIPTION	ITEM NO

DIMENSIONS: mm		TOLERANCES UNLESS OTHERWISE SPECIFIED:		DWG: HOFFNER 7FEB2012		CHK: T. ELBIN 8FEB2012		APVD: T. ELBIN 8FEB2012		NAME: T. ELBIN		TE Connectivity Harrisburg, PA 17105-3608	
0 PLC ±		1 PLC ±		2 PLC ±		3 PLC ±		4 PLC ±		5 PLC ±		6 PLC ±	
MATERIAL: -		FINISH: -		WEIGHT: -		SCALE: A1 00779		CAGE CODE: -		DRAWING NO: -		RESTRICTED TO: -	
Customer Accessible Production Drawing										SCALE: 1:1		SHEET 3 OF 4	

LOC		DIST		REVISIONS			
A	66	P	LTM	DESCRIPTION	DATE	OWN	APVD
				SEE SHEET 1			

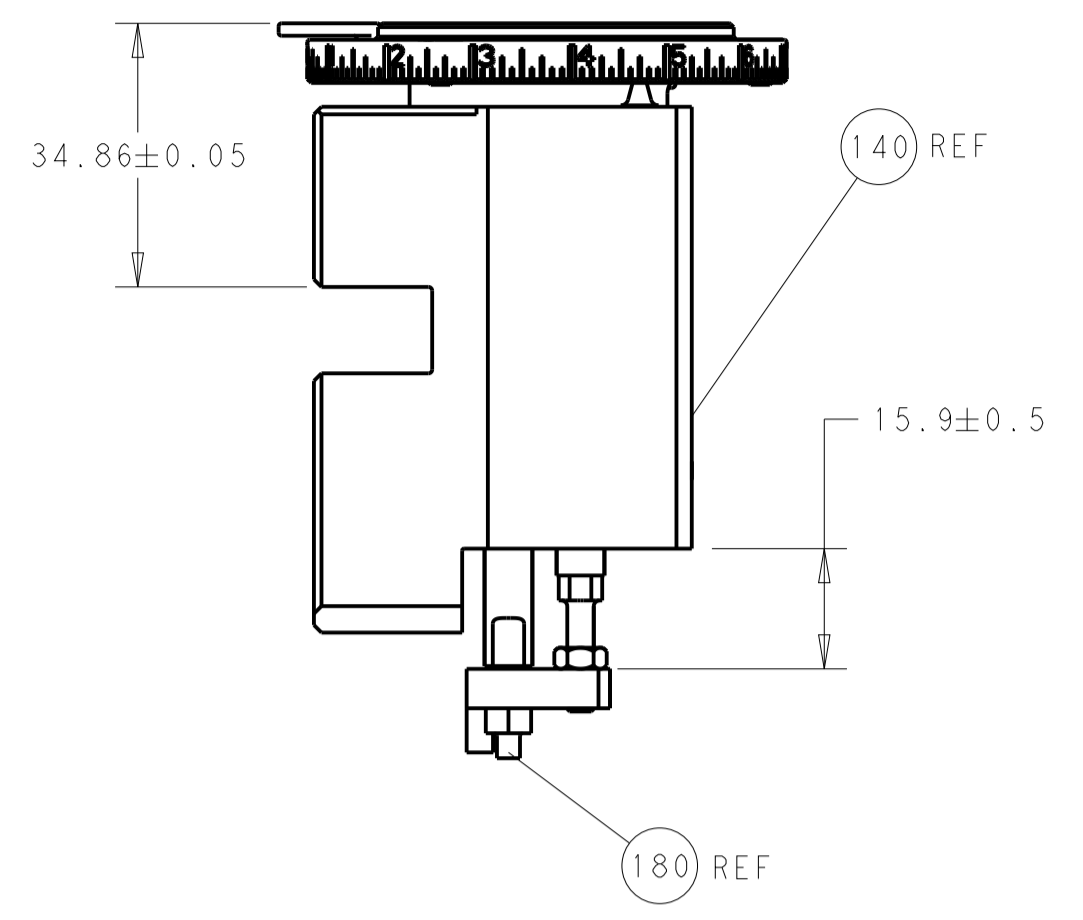

RAM AND HOLDDOWN SET-UP

FEED TYPE
MECHANICAL

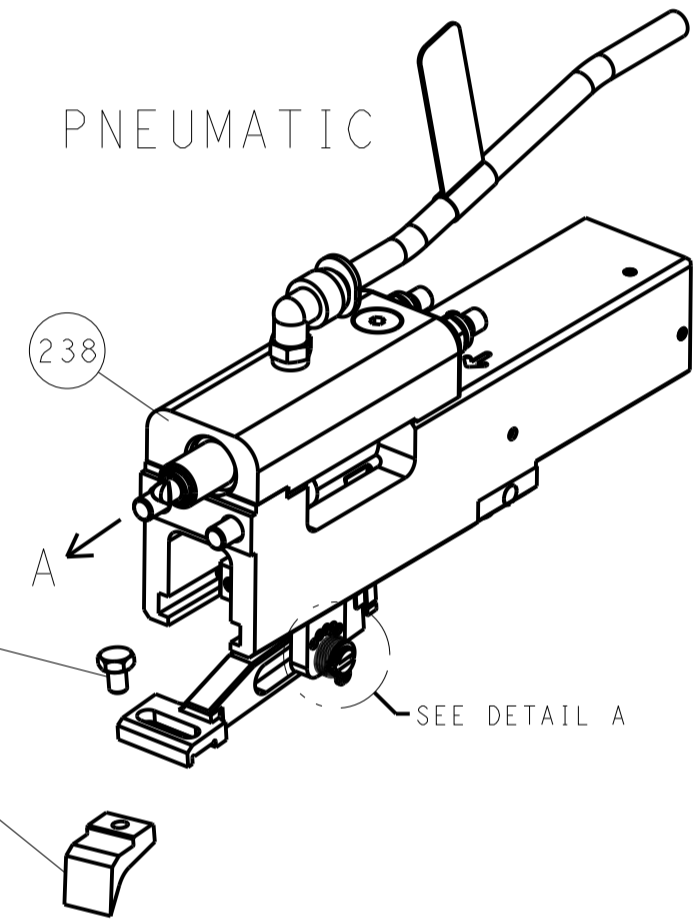
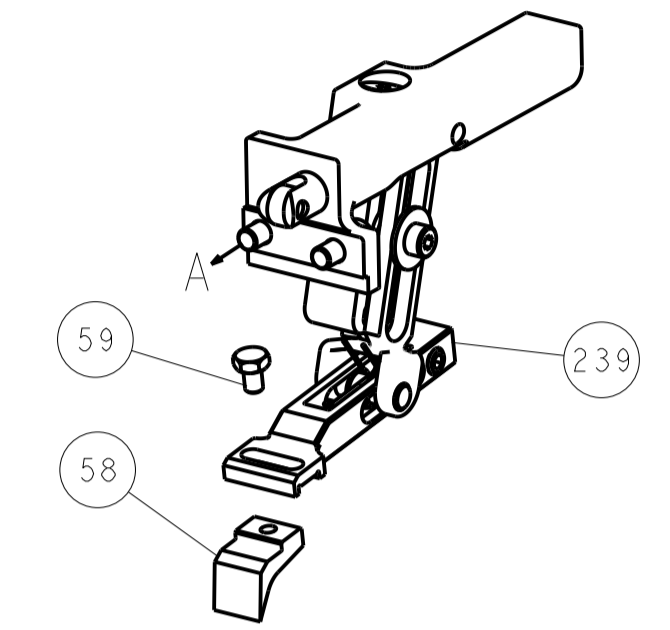

FEED SPRING
SETTING POSITION

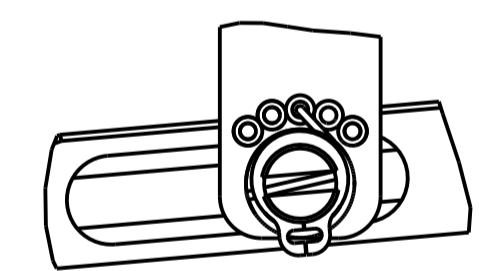

DETAIL A

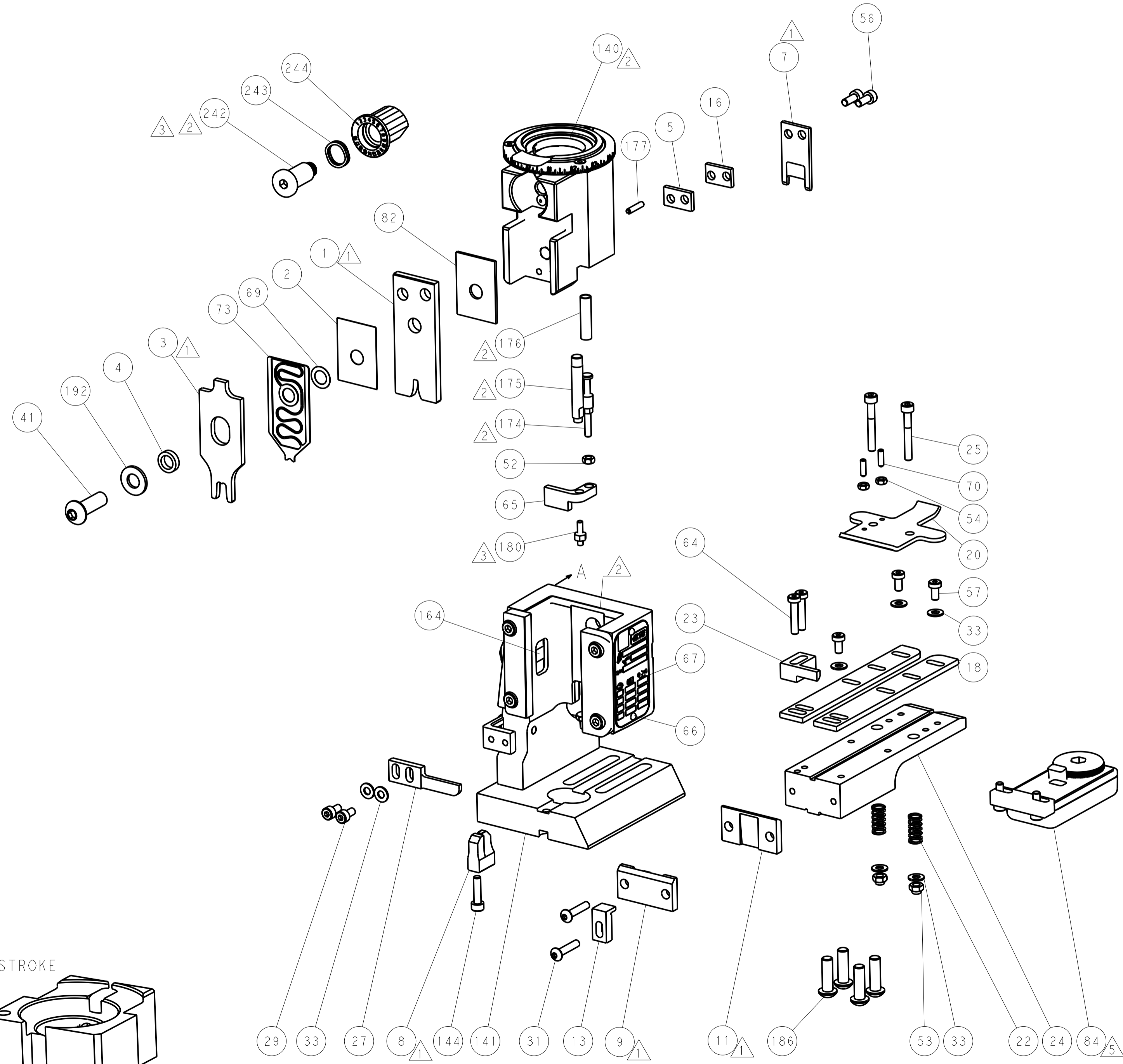

CAM POSITIONS

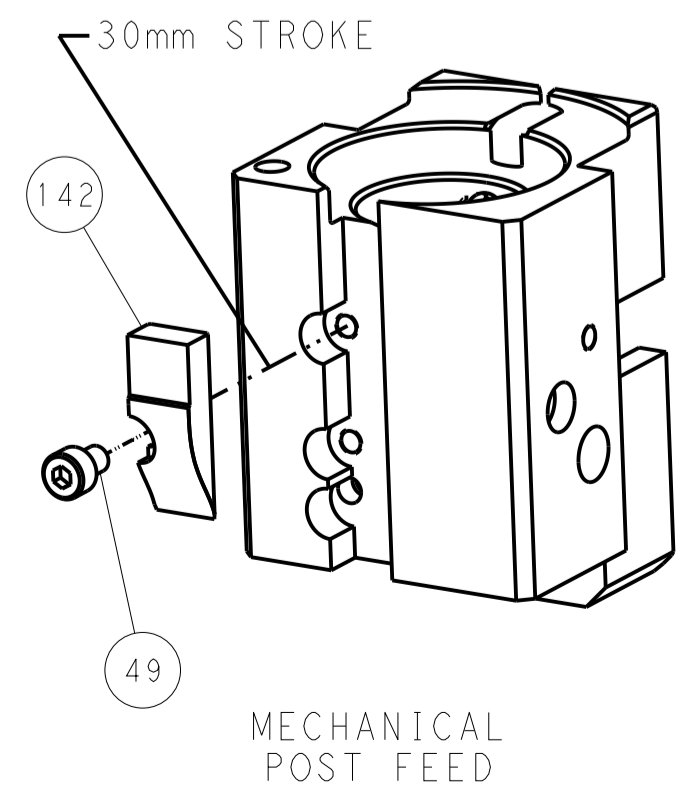

MECHANICAL POST FEED

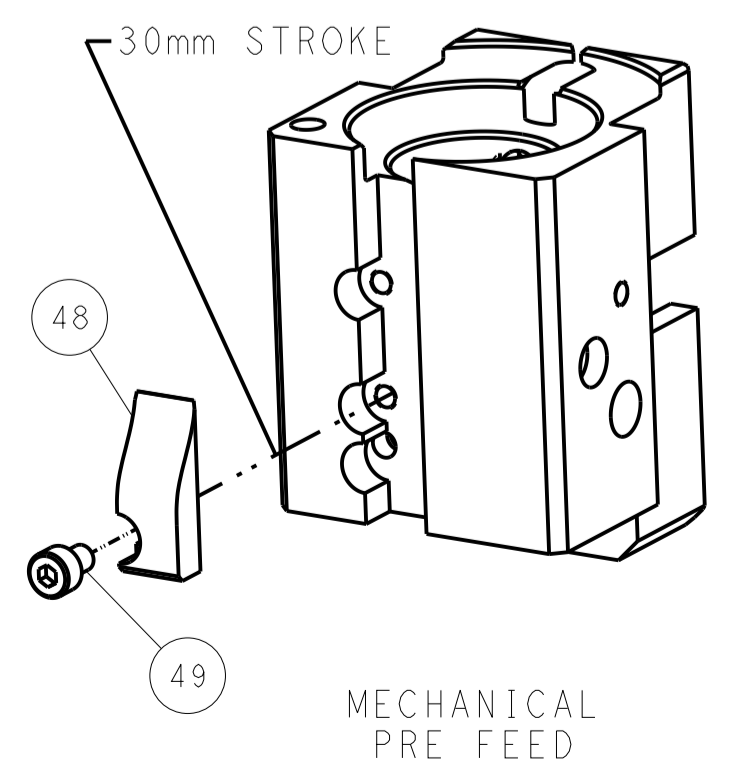

MECHANICAL PRE FEED

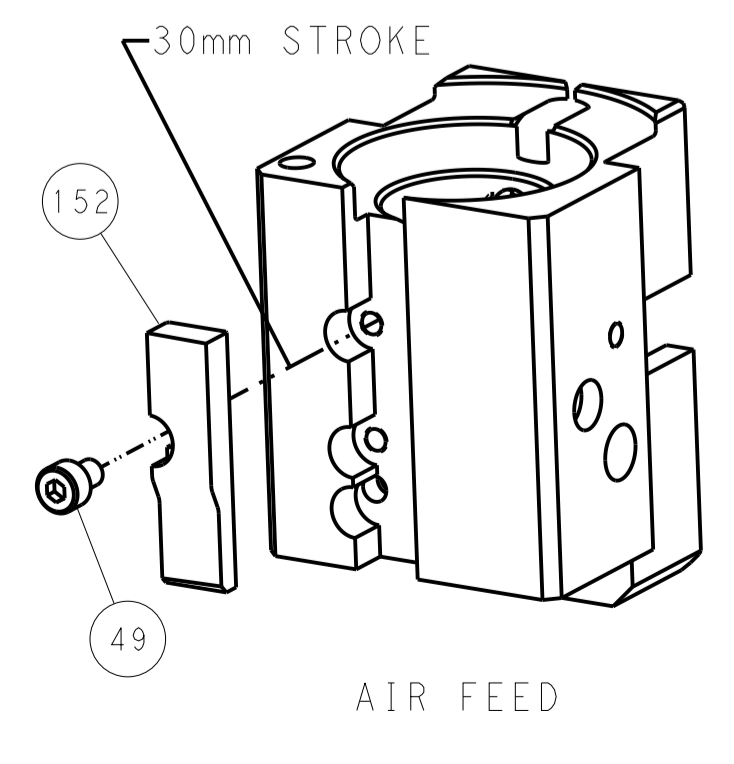

AIR FEED

PACIFIC VERSION
 Shown on sheets 3 of 4 & 4 of 4
 (Atlantic version shown on sheets 1 of 4 & 2 of 4)

DIMENSIONS:		TOLERANCES UNLESS OTHERWISE SPECIFIED:		OWN: HOFFNER 7FEB2012		TE Connectivity	
mm	0 PLC ±	1 PLC ±	2 PLC ±	3 PLC ±	4 PLC ±	5 PLC ±	Harrisburg, PA 17105-3608
	ANGLES			APVD: T. ELBIN 8FEB2012	NAME: Ocean End Feed Applicator		
MATERIAL:	FINISH:	WEIGHT:	SCALE: 1:1	SIZE: A1	CAGE CODE: 00779	DRAWING NO: C=2150247	RESTRICTED TO:
Customer Accessible Production Drawing				SHEET 4 OF 4	REV G		