

**FEATURES**

- DESIGNED FOR HEAVY SHOCK AND VIBRATION.
- UNIFORM CLAMPING FORCE AND HIGH THERMAL TRANSFER.
- NARROW WIDTH FOR MAXIMUM PCB COMPONENT AREA.
- LOW PROFILE DESIGN ALLOWS FOR DECREASED SLOT PITCH.
- CAPTIVATED REAR WEDGE.
- LIGHT WEIGHT = ASSEMBLY LENGTH X .080 OZ [2.27 G] OR [.89 G/CM].
- SPECIAL LENGTHS, FINISH, AND OTHER DESIGN OPTIONS AVAILABLE UPON REQUEST.

**MATERIAL**

MOUNTING BAR AND WEDGES: ALUMINUM 6063-T6.  
 ALL OTHER HARDWARE: 18-8 STAINLESS STEEL, PASSIVATED.

PARTS ARE SHIPPED AS COMPLETE ASSEMBLY IN RELAXED STATE EXCEPT FOR RIVET MOUNT OPTION.

RECOMMENDED DRIVE SCREW TORQUE IS 6 IN-LBS [68 N-CM].

**PROPRIETARY AND CONFIDENTIAL**  
 THE INFORMATION CONTAINED IN THIS DRAWING IS THE SOLE PROPERTY OF WAKEFIELD-VETTE. ANY REPRODUCTION IN PART OR AS A WHOLE WITHOUT THE WRITTEN PERMISSION OF WAKEFIELD-VETTE IS PROHIBITED.  
 MATERIAL: SEE PART DETAILS  
 FINISH: SEE FINISH TABLE

UNLESS OTHERWISE SPECIFIED:  
 DIMENSIONS ARE IN INCHES  
 TOLERANCES:  
 MACHINED SURFACES  $\sqrt{63}$   
 ANGULAR  $\pm 1^\circ$   
 TWO PLACE DECIMAL  $\pm .02$   
 THREE PLACE DECIMAL  $\pm .005$   
 INTERPRET GEOMETRIC TOLERANCING PER: ASME Y-14.5M  
 DO NOT SCALE DRAWING

DRAWN	NAME	DATE
CHECKED	RSB	25 JAN 2013
APPR.		
THIRD ANGLE PROJECTION		
CAGE CODE	3E7UB	

TITLE: WEDGELock DATASHEET  
 .225 X .225 PROFILE

SIZE	DWG. NO.	REV
<b>C</b>	<b>422C-DS</b>	<b>08/13</b>
SCALE: NONE	SHEET 1 OF 2	

[LLL] LENGTH TABLE			
ASSY LENGTH [LLL]	[H] MTG X	[C] OPTION X/2	
280	0.900	0.450	
330	1.400	0.700	
380	1.900	0.950	
430	2.400	1.200	
480	2.900	1.450	
530	3.400	1.700	
580	3.900	1.950	
OTHER LENGTHS AVAILABLE UPON REQUEST			

**PART#1 EXAMPLE: 422C-480UMG**  
 4.80" LENGTH, M2 MOUNT HOLES, METRIC M2.5 SOCKET HEAD, GOLD CHEM FILM

**PART#2 EXAMPLE: 422C-480UMG-CP**  
 SAME AS ABOVE PLUS CENTER MOUNTING HOLE AND LOCK PATCH OPTIONS

[H] MOUNTING TABLE	
DASH NO	DESCRIPTION
A	NO MOUNTING HOLES
R	$\phi .068 / .073$ THRU $\checkmark 100^\circ \times \phi .213$
T	#0-80 UNF-2B THREADS
S	#2-56 UNC-2B THREADS
U	M2 X .4-6H THREADS
M	M2.5 X .45-6H THREADS

[x] FINISH TABLE	
DASH NO	DESCRIPTION
A	NONE
C	CHEM FILM PER MIL-DTL-5541, CLASS 1A, TYPE I (CLEAR)
G	CHEM FILM PER MIL-DTL-5541, CLASS 1A, TYPE I (GOLD)
B	BLACK ANODIZE PER MIL-A-8625, TYPE II, CLASS 2
H	HARD BLACK ANODIZE PER MIL-A-8625, TYPE III, CLASS 2
N	NICKEL PLATE PER QQ-N-290, CLASS 1, GRADE G, BRIGHT
E	ELECTROLESS NICKEL PER MIL-C-26074, CLASS 4, GRADE B, BRIGHT
T	TRIVALENT CHEM FILM PER MIL-DTL-5541, CLASS 1A, TYPE II (CLEAR), RoHS COMPLIANT
ALL THREADS ARE GAUGED PRIOR TO PLATING	

### PART NUMBER CODE

422C - [LLL] [H] [D] [F] - [C] [K] [P] [V]

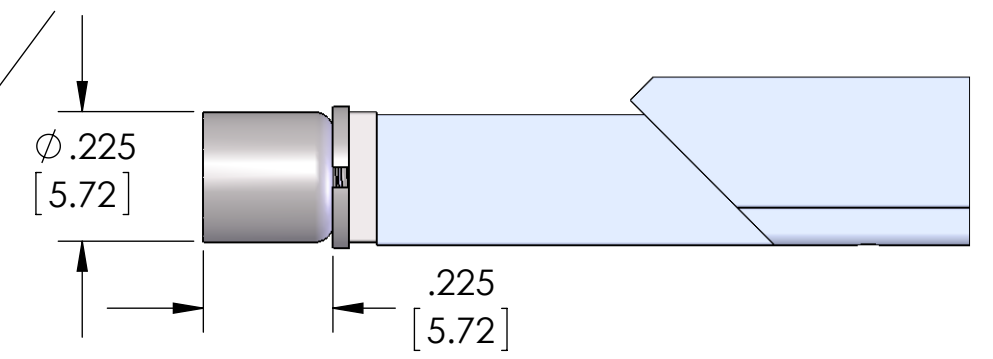
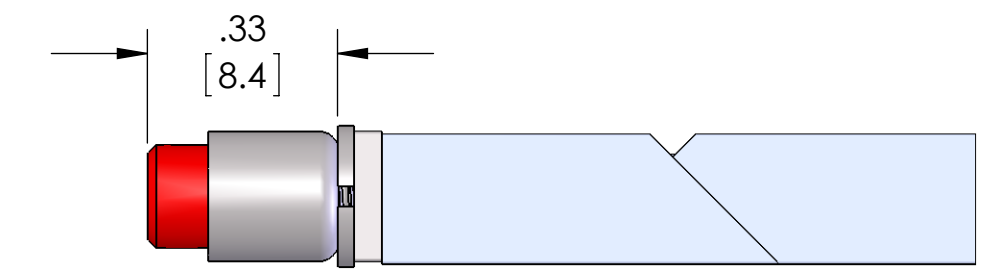
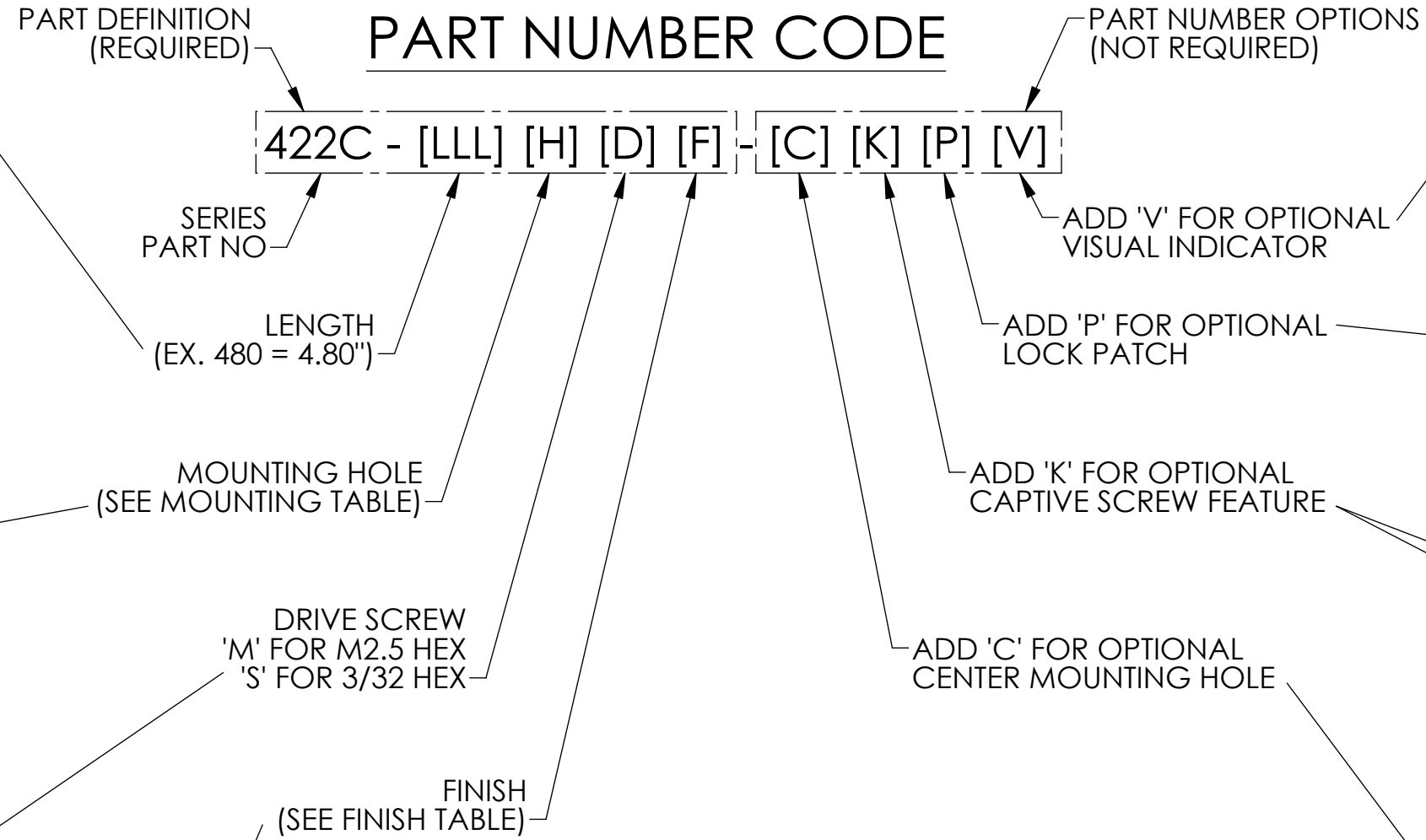

**'V' OPTION**  
 VISUALLY CONFIRMS LOCKED IN PLACE WHEN RED SCREW HEAD IS CONCEALED

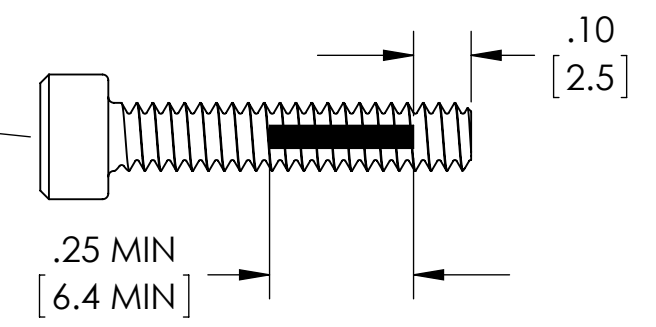

**'P' OPTION**  
 NYLON PATCH PER MIL-F-18240 PROVIDES ADDITIONAL RESISTANCE TO SHOCK AND VIBRATION

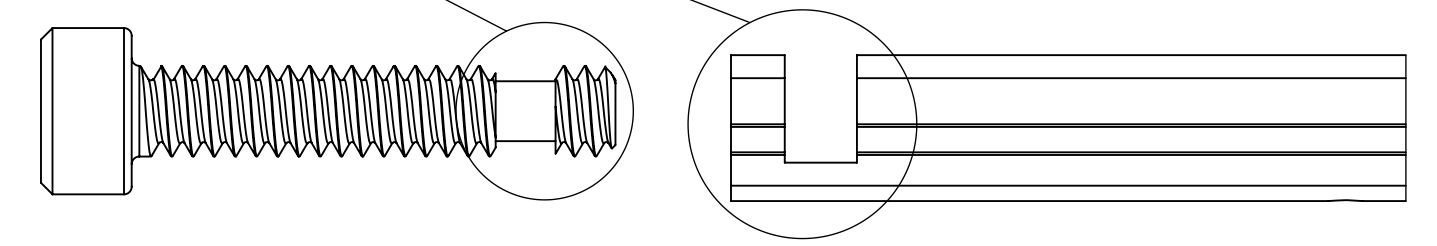

**'K' OPTION**  
 CAPTIVATES SCREW BY FREE-SPINNING WHEN WEDGELOCK IS IN RELAXED POSITION

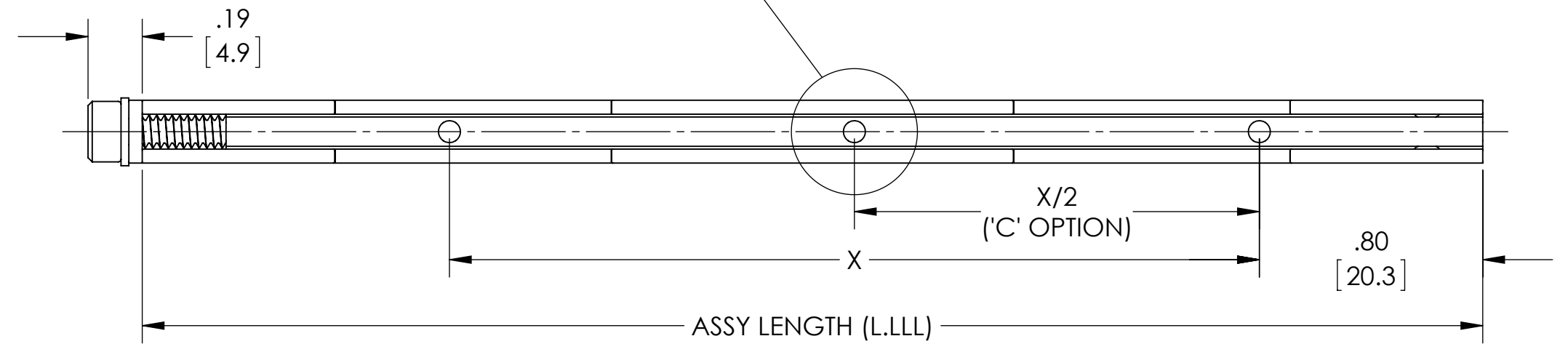

### BOTTOM VIEW