

#31095

Mini FOC ESC Based on VESC®6

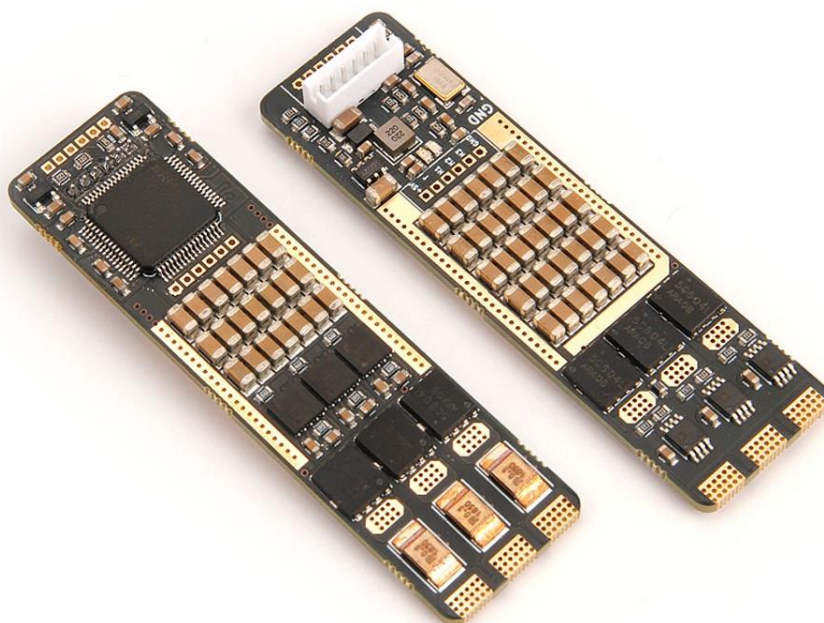

Specification

- Continuous Current: 20A
- Burst Current: 40A
- Input Voltage: 48V(8S)
- Hardware based upon the VESC® 6.0
- Firmware updatable
- VESC_TOOL Compatible Software
- Compatible with Sensored / Sensorless Motor
- Size: 18mm*65mm
- Net Weight: 10g/pcs

Port Definition:

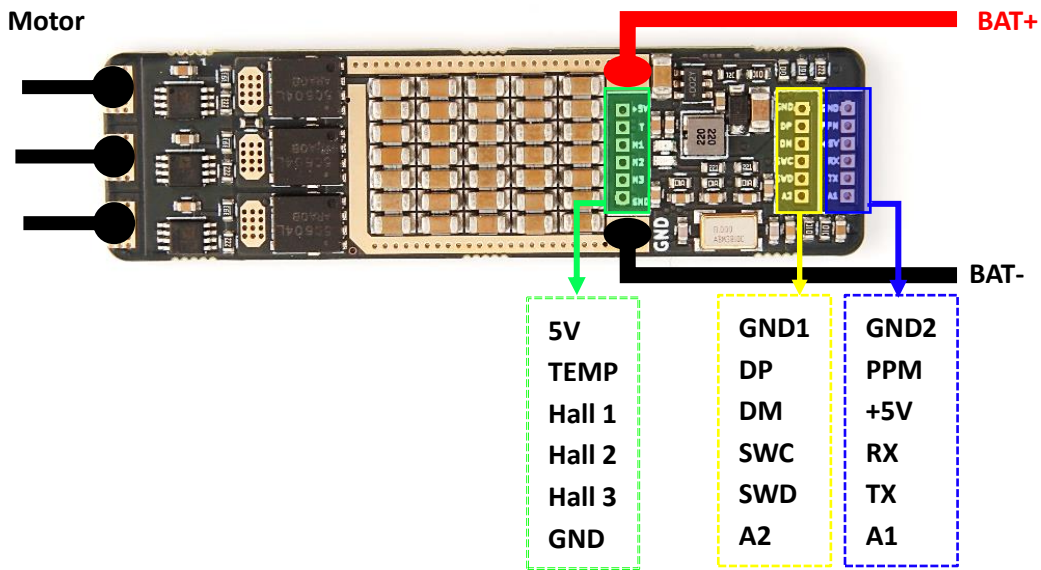

- GND1/2, DP(Data positive), DM(Data Minus/Negative): USB port for programming.
 - GND1/2, PPM, +5V: PPM port to connect PPM transceivers.
 - SWC(CLK), SWD(DIO), GND1/2, 5V: SWD port, to get direct access to the Chipset. Diagnostics, debugging, and real time data.
 - A1(ADC1), A2(ADC2), TX, RX, GND1/2, 5V: COMM port for various kinds of other communication methods like I2C, ADC, Uart. You can use your Arduino or Raspberry Pi to control the VESC.
 - 5V, TEMP, HALL1, Hall2, Hall3 GND: Sensor port for motor Hall sensors (ABI, HALL, magnetic precision encoders).
- PS: (GND1 and GND2 are same, for above ports containing GND1/2, you can just select one to use).

Things to note when you receive the ESC:

All products had been tested before shipment.

- When you receive the VESC, please test without load and do not connect motor, first check if the VESC can successfully connect to your computer, if ok, then connect to motor and you can start to adjust parameters.
- Do not use switching power supply, the instant voltage when switching power supply connect to VESC is very high, which would easy damage the VESC.
- Do not push the throttle too hard when test without load, gently and slowly speed up.

- Be cautious when adjust parameters, if parameters set mistake, would also easy damage the VESC.
- Please must remember to change to corresponding modes when you adjust parameters, for example, the VESC default mode is BLDC mode, but if you want to detect FOC mode and adjusted FOC parameters, at this time if mode in VESC_TOOL didn't change to FOC mode, then when you push throttle, would easy burn the VESC, same as FOC mode.
- In FOC mode, ERPM suggest to control in 30000-40000; In BLDC moed, ERPM suggest to control in 50000-60000, otherwise driver IC would easy to be damaged. ERPM= motor pole pairs number * KV * Voltage
ERPM= motor pole pairs number * KV * Voltage
- If you use UART port, the wire better do not over 0.5m or even shorter, and better use Stranded wire.
- The above are only suggestions based on the experience of our engineers. how to actually operate is up to you. Please note that parameters for different setup is also different.

Package included:

Mini FOC ESC *1

Electrolytic capacito: 220uF 63v *1

DIP Rectifier Diode *1

Clear Heat Shrink Tube*1

16AWG 100mm Red wire *1

16AWG 100mm Black wire *1

This ESC is manufactured based upon the open hardware design by Anton Chromjak with consent. For more information, please visit:

<https://vesc-project.com/node/246>

<https://github.com/antonchromjak/MINI4>

Vesc-tool download:

https://github.com/rpasichnyk/vesc_tool/releases

Holybro is a registered trademark of Holybro, registered in the U.S. and other countries.

©Copyright 2018 Holybro. All Rights Reserved.