

| TABLE OF CONTENTS | |
|-------------------|--------------------------|
| SHEET NO. | SHEET DESCRIPTION |
| 1 | NOTES AND BOM |
| 2 | CONFIGURATIONS |
| 3-4 | KEY CONFIGURATIONS |
| 5 | BLADE SEALED ASSEMBLY |
| 6 | SYSTEM PACKAGING |
| 7 | BACKSHELL NOTES |
| 8 | BACKSHELL |
| 9 | BACKSHELL CONFIGURATIONS |

NOTES: VALID UNLESS OTHERWISE SPECIFIED

1. GENERAL:
- a. APPLICATION SPECIFICATION SEE: AS-33472-100
- CONTAINS: PRODUCT INTRODUCTION, PRODUCT SUMMARY, CONNECTOR ASSEMBLY, PACKAGING INFORMATION, CONNECTOR MATING, SERVICE INSTRUCTIONS, ELECTRICAL CONTINUITY CHECKING, CRIMPING, AND TROUBLESHOOTING.
 - DESIGNED TO MATE WITH RECEPTACLE SEALED ASSEMBLY AS SPECIFIED IN THE MATING CONNECTOR DRAWINGS CHART.
 - *DENOTES DRAWINGS THAT CAN BE ACCESSED AT <http://ewcap.uscarteams.org/>
 - ASSEMBLY SHIPPED WITH PLR IN PRE-LOCK POSITION (SEE PLR PRE-LOCK VIEW SHEET 5).
- b. PRODUCT SPECIFICATION SEE:
- STANDARD CONFIGURATION: PS-33471-000
 - UL V0 CONFIGURATION: PS-160105-0001
 - CONTAINS: PRODUCT INTRODUCTION, PRODUCT SUMMARY, RATINGS (CURRENT, TEMPERATURE, SEALING, AND FLAMMABILITY), TERMINALS, WIRE DIAMETER RANGE, PRODUCT VALIDATION, AND PRODUCT DEVIATIONS.
- c. PACKAGING SPECIFICATION PER MOLEX DRAWING: PK-31300-635 (PK-33471-000 FOR 1X5)
- d. PARTS MUST BE IN COMPLIANCE TO MOLEX CHEMICAL SUBSTANCES FOR PRODUCTS AND PACKAGING SPECIFICATION: QEHS-699000-300
- e. DATA MUST BE SUBMITTED UNDER THE MOLEX PART NUMBER TO IMDS (COMPANY ID#13255)
2. DESIGN - MATERIALS:
- a. FOR BILL OF MATERIALS SEE:
- STANDARD CONFIGURATION: SD-33481-0002
 - UL V0 CONFIGURATION: SD-160106-0002
3. DESIGN - GEOMETRY:
- a. THE 3-D CAD DATA IS BASIC (WITHOUT TOLERANCE) AND MASTER FOR THIS PART WITH THE EXCEPTION OF UNDERLINED DIMENSIONS. DIMENSIONAL INFORMATION NOT SHOWN ON THIS DRAWING IS DEFINED BY THE DATA FILE AT ITS LATEST REVISION.
- b. GEOMETRIC DIMENSIONS AND TOLERANCES PER ASME Y14.5M-2009
- c. EDGES AND UNDIMENSIONED DETAILS PER ISO13715
- d. CORNERS SHOWN AS SHARP TO BE R 0.2 MAX.
- e. LETTERING SHALL BE 0.15 MAX RAISED IN 0.25 MAX RECESS PAD. THIS INCLUDES RECYCLING CODE, CAVITY ID, VENDOR IDENTIFICATION, AND CUSTOMER MATERIAL NUMBER.
- f. VISUAL DEFECTS SHALL MEET COSMETIC STANDARD PS-45499-002 (Class B).
- g. LASER MARKING:
- PART NUMBER
 - DAY OF THE YEAR
 - SHIFT
 - YEAR
- FOR ADDITIONAL INFORMATION SEE SECTION 5 UNDER PROCEDURES IN ES-34735-008.

| MATING CONNECTOR DRAWINGS | |
|---------------------------|---------------|
| DESCRIPTION | MOLEX INLINE |
| 1X2 | SD-33471-0001 |
| | |
| | |
| | |
| 1X6 | SD-33471-0001 |

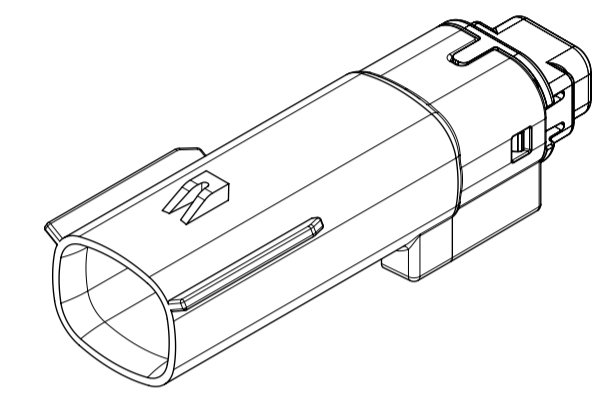

1X2

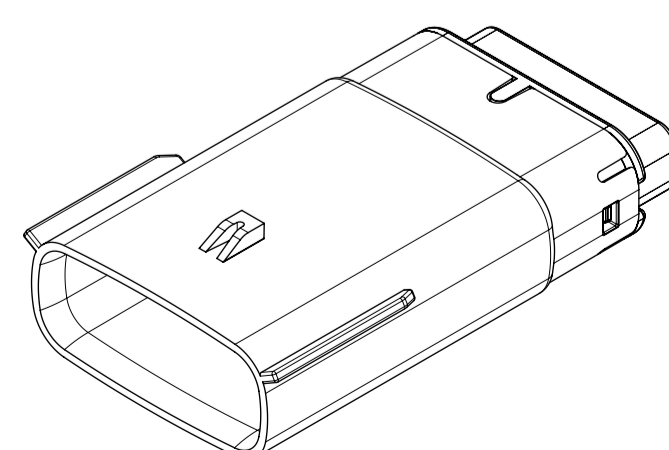
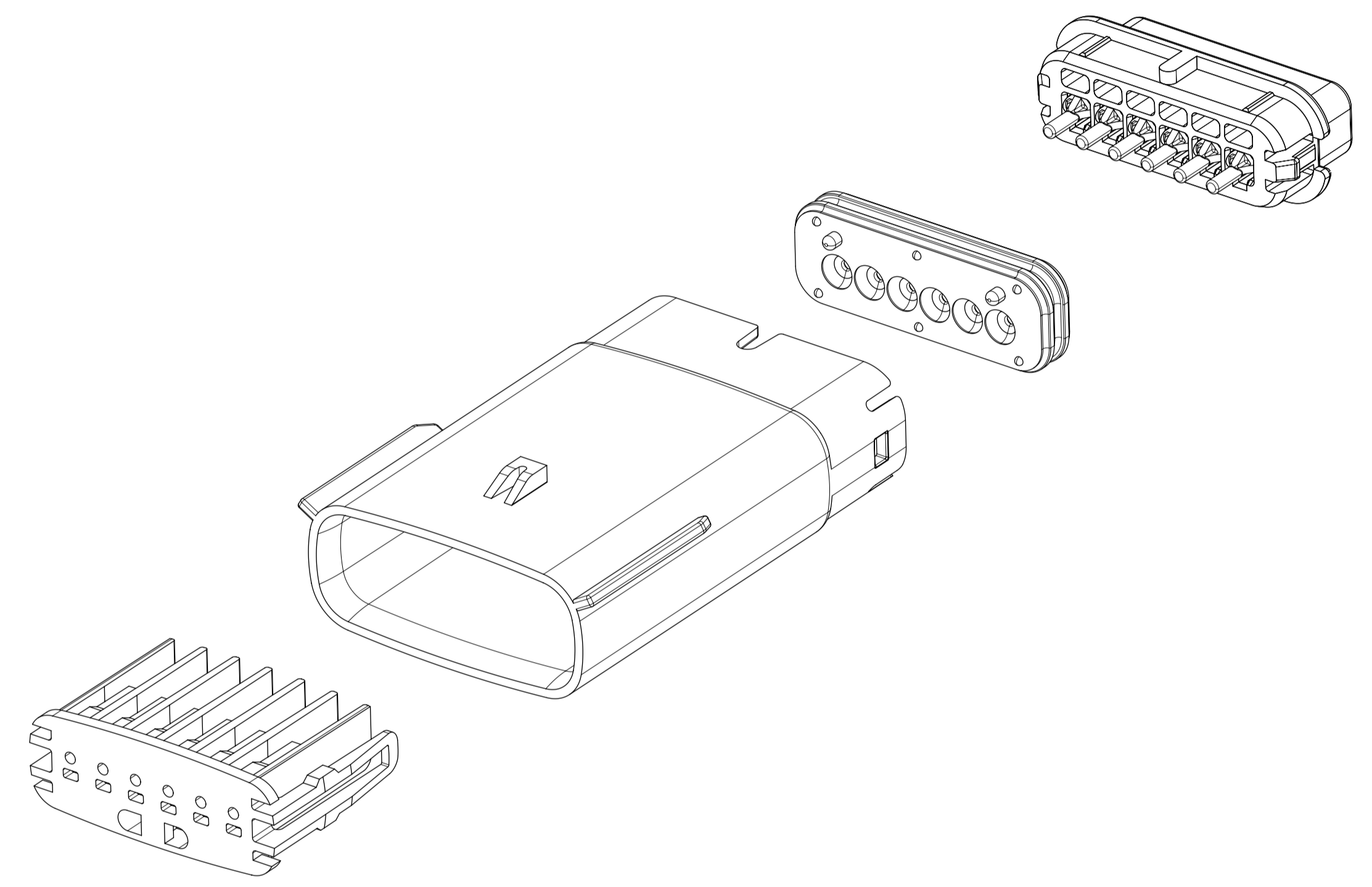

1X6

| INSPECTION NUMBER LOG | |
|-----------------------|--------|
| LAST NUMBER: | ADDED: |
| 9 | 1 |
| REMOVED: | REV |

| REV | REV DESCRIPTION |
|-----|----------------------------------------------------------------------------------------------|
| A1 | NX REMASTERING , CHANGE PS DRAWING NUMBER FROM PS-160105-0001 TO PS-160074-0001 IN NOTES 1.b |
| A | MINOR GEOMETRY CHANGE FOR UL V0 |
| 2 | UPDATED VIEWSETS |
| 1 | INITIAL RELEASE |

| | | | | |
|-------------------------------------------------------------------------------|---------------------------------------------------------------------------------------------------------------------------------------------------------------------------------------------------------|---------------------------------------------------------------------------------------------------------------------------------------------------------------------------------------------------------------------|--------------------------------------------------------------------------------------------------------------|--------------------------------------------------------------------------------------------------------|
| SYMBOLS = 0 = 0 = 0 = 0 = 0 = 0 = 0 = 0 = 0 | THIS DRAWING CONTAINS INFORMATION THAT IS PROPRIETARY TO MOLEX ELECTRONIC TECHNOLOGIES, LLC AND SHOULD NOT BE USED WITHOUT WRITTEN PERMISSION DIMENSION UNITS: MM ONLY SCALE: 1.5:1 | CURRENT REV DESC: EC NO: 602373 DRWN: DSHETTY01 2018/05/25 CHK'D: MVANSLAMBROU 2018/10/04 APPR: MVANSLAMBROU 2018/10/04 INITIAL REVISION: DRWN: APROFFITT 2015/07/21 APPR: KDEKOSKI 2016/06/14 | MX150 BLADE SINGLE ROW SEALED ASSY MAT SEAL PRODUCT CUSTOMER DRAWING | |
| | GENERAL TOLERANCES (UNLESS SPECIFIED) ANGULAR TOL ± 1.0° 4 PLACES ± 3 PLACES ± 2 PLACES ± 0.1 1 PLACE ± 0.2 0 PLACES ± | DRAFT WHERE APPLICABLE MUST REMAIN WITHIN DIMENSIONS THIRD ANGLE PROJECTION DRAWING: A1-SIZE SERIES: 33481 | DOCUMENT NUMBER: SD-33481-0001 DOC TYPE: PSD DOC PART: 001 REVISION: A1 | MATERIAL NUMBER: SEE NOTE 2a. CUSTOMER: GENERAL MARKET SHEET NUMBER: 1 OF 9 |
| | DOCUMENT STATUS: P1 RELEASE DATE: 2018/10/04 15:02:02 | | | |
| | 18 17 16 15 14 13 12 11 10 9 8 7 6 5 4 3 2 1 | | | |

SHEET DESCRIPTION
CONFIGURATIONS

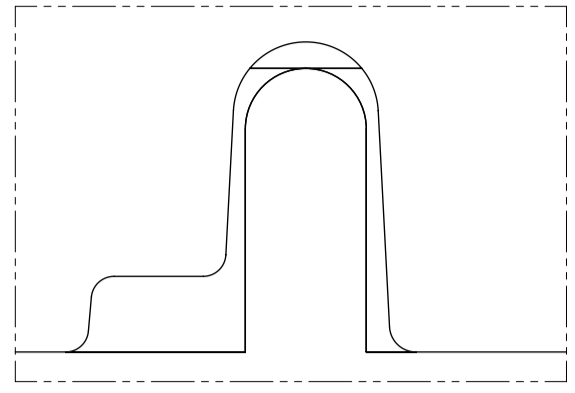

UL V0 UNIQUE FEATURE
Partial1
SCALE 10:1

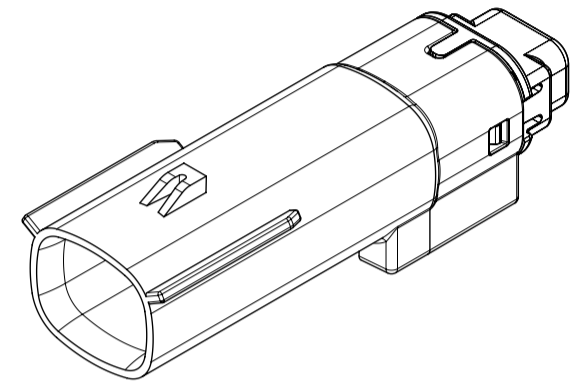

1x2 - STD

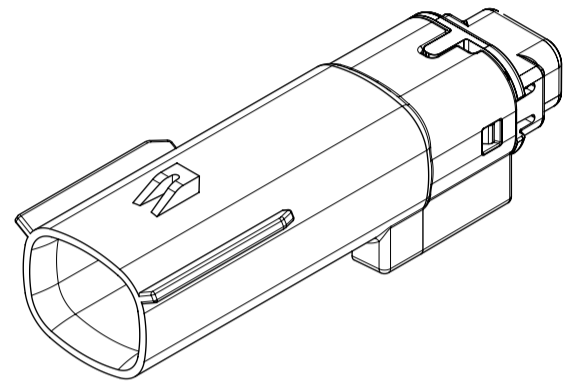

1X2 - UL V0*

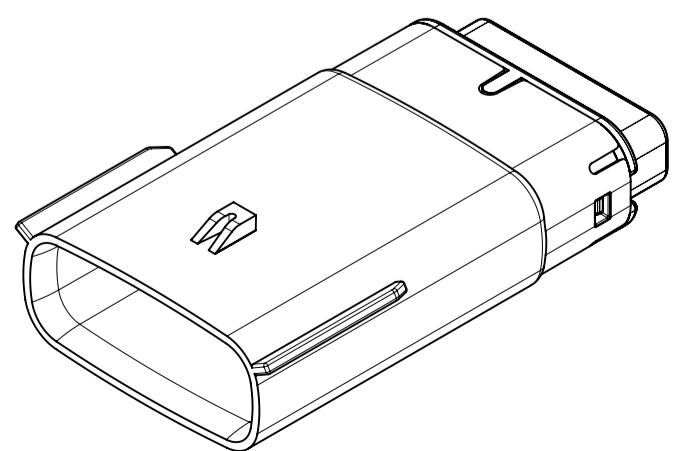

1x6 - STD

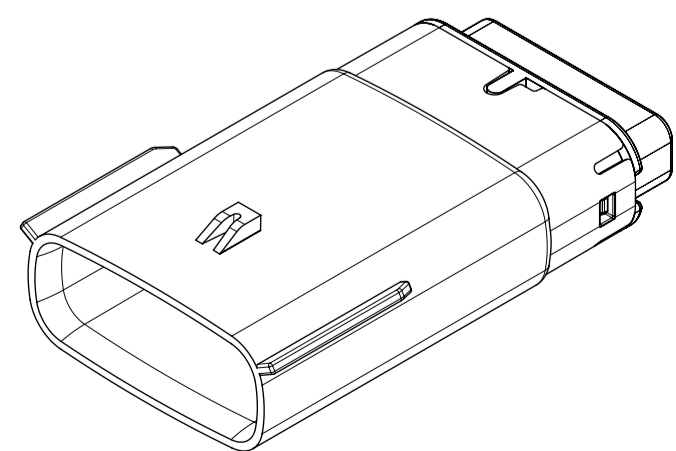

1x6 - UL V0*

* MINOR GEOMETRY DIFFERENCE THAN STANDARD CONFIGURATION.
SEE NOTES 1 & 2 FOR MORE INFORMATION

| | | | | | | | |
|---------|-----------------------------------------------------------------------------------------------------------------------------------------------|-------|------------------------------------------------------|--|------------------------|-----------------|--------------------------|
| SYMBOLS | THIS DRAWING CONTAINS INFORMATION THAT IS PROPRIETARY TO MOLEX ELECTRONIC TECHNOLOGIES, LLC AND SHOULD NOT BE USED WITHOUT WRITTEN PERMISSION | | CURRENT REV DESC: | | | | |
| | DIMENSION UNITS | SCALE | | | | | |
| ▽ = 0 | MM ONLY | 1.5:1 | GENERAL TOLERANCES (UNLESS SPECIFIED) | | CHK'D: MVANSLAMBROU | 2018/10/04 | PRODUCT CUSTOMER DRAWING |
| ▽ = 0 | ANGULAR TOL ± 1.0° | | APPR: MVANSLAMBROU | | 2018/10/04 | DOCUMENT NUMBER | |
| ▽ = 0 | 4 PLACES | ± | INITIAL REVISION: | | DRWN: APROFFITT | 2015/07/21 | SD-33481-0001 |
| ▽ = 0 | 3 PLACES | ± | APPR: KDEKOSKI | | 2016/06/14 | DOC TYPE | |
| ▽ = 0 | 2 PLACES | ± 0.1 | DRAFT WHERE APPLICABLE MUST REMAIN WITHIN DIMENSIONS | | THIRD ANGLE PROJECTION | DRAWING | PSD |
| ▽ = 0 | 1 PLACE | ± 0.2 | THIRD ANGLE PROJECTION | | DRAWING | SERIES | |
| ▽ = 0 | 0 PLACES | ± | THIRD ANGLE PROJECTION | | DRAWING | SERIES | A1 |
| ▽ = 0 | DRAFT WHERE APPLICABLE MUST REMAIN WITHIN DIMENSIONS | | THIRD ANGLE PROJECTION | | DRAWING | SERIES | |
| ▽ = 0 | DRAFT WHERE APPLICABLE MUST REMAIN WITHIN DIMENSIONS | | THIRD ANGLE PROJECTION | | DRAWING | SERIES | MATERIAL NUMBER |
| | | | THIRD ANGLE PROJECTION | | DRAWING | SERIES | CUSTOMER |
| | | | THIRD ANGLE PROJECTION | | DRAWING | SERIES | SHEET NUMBER |
| | | | THIRD ANGLE PROJECTION | | DRAWING | SERIES | 2 OF 9 |

SHEET DESCRIPTION
KEY CONFIGURATIONS

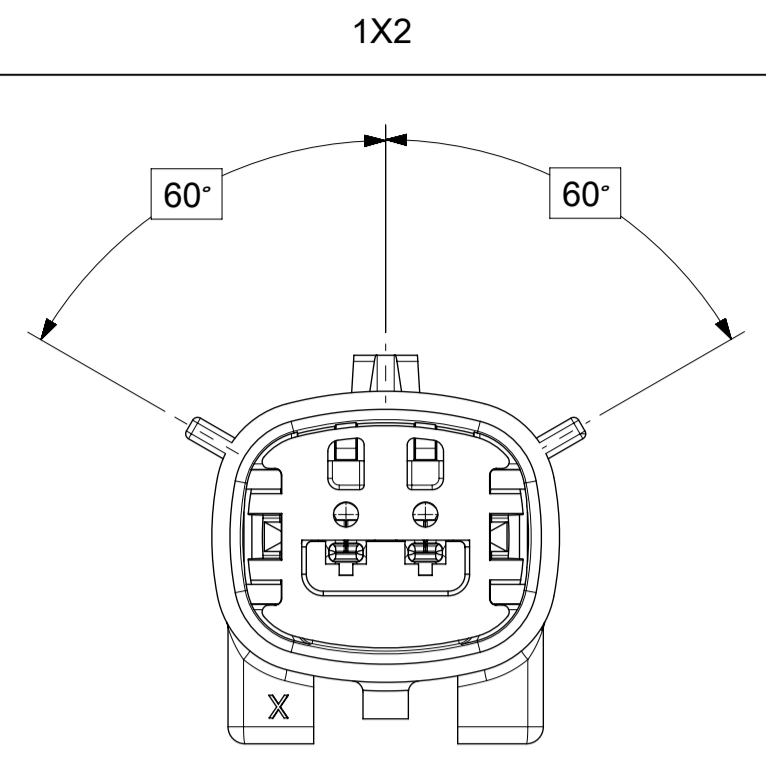

KEY A

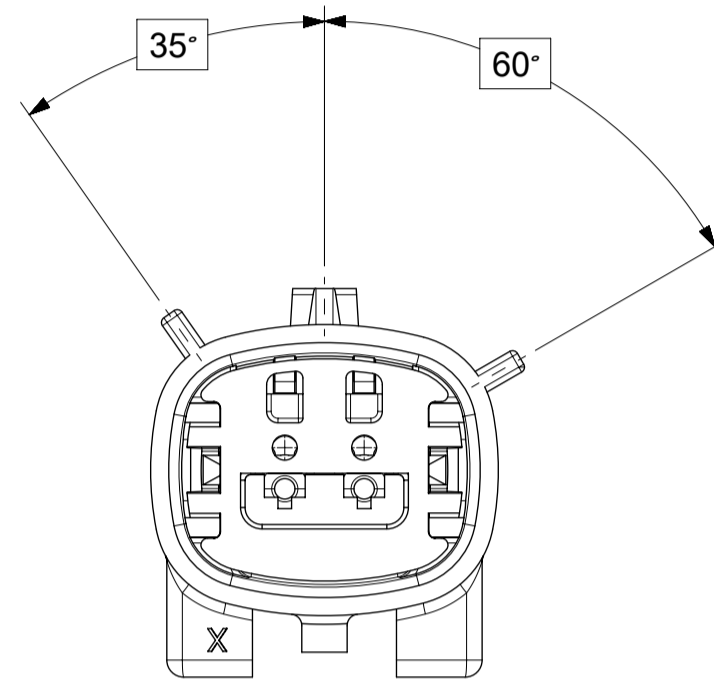

KEY B

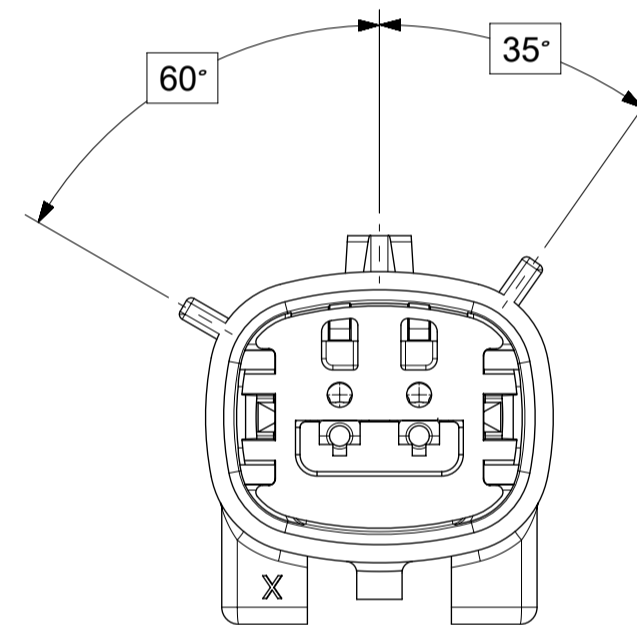

KEY C

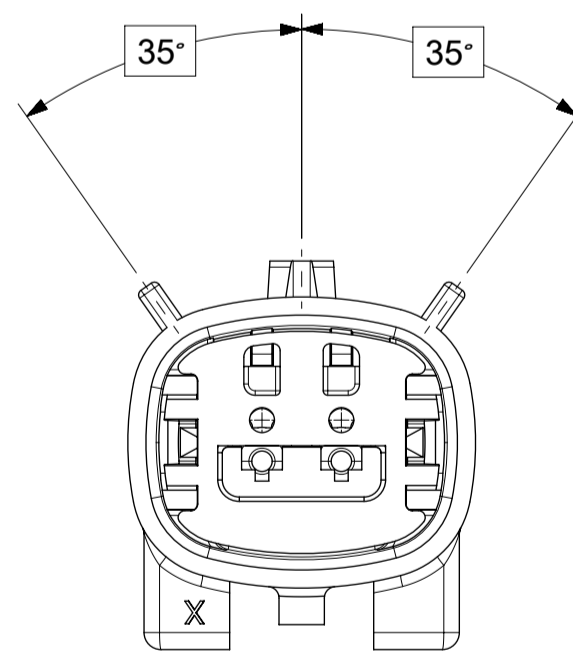

KEY D

| | | | |
|----------------------------------------------------------------------------------------------------------------------------------------------------------------------------------------------------------------------------------------------------------------------------------------------------------------------------------------------------------------------------------------------------------------------------------------------------------------------------------------------------------------------------------------------------------------------------------------------------------------------------------------------------------------------------------------------------------------------------------------------------------------------------------------------------------------------------------------------------------------------------------------------------------------------------------------------------------------------------------------------------------------------------------------------------------------------------------------------------------------------------------------------------------------------------------------------------------------------------------------------------------------------------------------------------------------------------------------------------------------------------------------------------------------------------------------------------------------------------------------------------------------------------------------------------------------------------------------------------------------------------------------------------------------------------------------------------------------------------------------------------------------------------------------------------------------------------------------------------------------------------------------------------------------------------------------------------------------------------------------------------------------------------------------------------------------------------------------------------------------------------------------------------------------------------------------------------------------------------------------------------------------------------------------------------------------------------------------------------------------------------------------------------------------------------------------------------------------------------------------------------------------------------------------------------------------------------------------------------------------------------------------------------------------------------------------------------------------------------------------------------------------------------------------------------------------------------------------------------------------------------------------------------------------------------------------------------------------------------------------------------------------------------------------------------------------------------------------------------------------------------------------------------------------------------------------------------------------------------------------------------------------------------------------------------------------------------------------------------------------------------------------------------------------------------------------------------------------------------------------------------------------------------------------------------------------------------------------------------------------------------------------------------------------|---------------------------------------------------------------------------------------------------------------------------------------------------------------------------------------------------------------------------------------------------------------------------------------------------------------------------------------------------------------------------------------------------------------|-----------------------------------------------------------------------------------------------------------------------------------------------------------------------------------------------------------------------------|-------------------------------------------------------------------------------------------------------------------------------------------------------------------------------------------------------------------------------------------------------------------------------|
| SYMBOLS = 0 = 0 = 0 = 0 = 0 = 0 = 0 = 0 = 0 = 0 = 0 = 0 = 0 = 0 = 0 = 0 = 0 = 0 = 0 = 0 = 0 = 0 = 0 = 0 = 0 = 0 = 0 = 0 = 0 = 0 = 0 = 0 = 0 = 0 = 0 = 0 = 0 = 0 = 0 = 0 = 0 = 0 = 0 = 0 = 0 = 0 = 0 = 0 = 0 = 0 = 0 = 0 = 0 = 0 = 0 = 0 = 0 = 0 = 0 = 0 = 0 = 0 = 0 = 0 = 0 = 0 = 0 = 0 = 0 = 0 = 0 = 0 = 0 = 0 = 0 = 0 = 0 = 0 = 0 = 0 = 0 = 0 = 0 = 0 = 0 = 0 = 0 = 0 = 0 = 0 = 0 = 0 = 0 = 0 = 0 = 0 = 0 = 0 = 0 = 0 = 0 = 0 = 0 = 0 = 0 = 0 = 0 = 0 = 0 = 0 = 0 = 0 = 0 = 0 = 0 = 0 = 0 = 0 = 0 = 0 = 0 = 0 = 0 = 0 = 0 = 0 = 0 = 0 = 0 = 0 = 0 = 0 = 0 = 0 = 0 = 0 = 0 = 0 = 0 = 0 = 0 = 0 = 0 = 0 = 0 = 0 = 0 = 0 = 0 = 0 = 0 = 0 = 0 = 0 = 0 = 0 = 0 = 0 = 0 = 0 = 0 = 0 = 0 = 0 = 0 = 0 = 0 = 0 = 0 = 0 = 0 = 0 = 0 = 0 = 0 = 0 = 0 = 0 = 0 = 0 = 0 = 0 = 0 = 0 = 0 = 0 = 0 = 0 = 0 = 0 = 0 = 0 = 0 = 0 = 0 = 0 = 0 = 0 = 0 = 0 = 0 = 0 = 0 = 0 = 0 = 0 = 0 = 0 = 0 = 0 = 0 = 0 = 0 = 0 = 0 = 0 = 0 = 0 = 0 = 0 = 0 = 0 = 0 = 0 = 0 = 0 = 0 = 0 = 0 = 0 = 0 = 0 = 0 = 0 = 0 = 0 = 0 = 0 = 0 = 0 = 0 = 0 = 0 = 0 = 0 = 0 = 0 = 0 = 0 = 0 = 0 = 0 = 0 = 0 = 0 = 0 = 0 = 0 = 0 = 0 = 0 = 0 = 0 = 0 = 0 = 0 = 0 = 0 = 0 = 0 = 0 = 0 = 0 = 0 = 0 = 0 = 0 = 0 = 0 = 0 = 0 = 0 = 0 = 0 = 0 = 0 = 0 = 0 = 0 = 0 = 0 = 0 = 0 = 0 = 0 = 0 = 0 = 0 = 0 = 0 = 0 = 0 = 0 = 0 = 0 = 0 = 0 = 0 = 0 = 0 = 0 = 0 = 0 = 0 = 0 = 0 = 0 = 0 = 0 = 0 = 0 = 0 = 0 = 0 = 0 = 0 = 0 = 0 = 0 = 0 = 0 = 0 = 0 = 0 = 0 = 0 = 0 = 0 = 0 = 0 = 0 = 0 = 0 = 0 = 0 = 0 = 0 = 0 = 0 = 0 = 0 = 0 = 0 = 0 = 0 = 0 = 0 = 0 = 0 = 0 = 0 = 0 = 0 = 0 = 0 = 0 = 0 = 0 = 0 = 0 = 0 = 0 = 0 = 0 = 0 = 0 = 0 = 0 = 0 = 0 = 0 = 0 = 0 = 0 = 0 = 0 = 0 = 0 = 0 = 0 = 0 = 0 = 0 = 0 = 0 = 0 = 0 = 0 = 0 = 0 = 0 = 0 = 0 = 0 = 0 = 0 = 0 = 0 = 0 = 0 = 0 = 0 = 0 = 0 = 0 = 0 = 0 = 0 = 0 = 0 = 0 = 0 = 0 = 0 = 0 = 0 = 0 = 0 = 0 = 0 = 0 = 0 = 0 = 0 = 0 = 0 = 0 = 0 = 0 = 0 = 0 = 0 = 0 = 0 = 0 = 0 = 0 = 0 = 0 = 0 = 0 = 0 = 0 = 0 = 0 = 0 = 0 = 0 = 0 = 0 = 0 = 0 = 0 = 0 = 0 = 0 = 0 = 0 = 0 = 0 = 0 = 0 = 0 = 0 = 0 = 0 = 0 = 0 = 0 = 0 = 0 = 0 = 0 = 0 = 0 = 0 = 0 = 0 = 0 = 0 = 0 = 0 = 0 = 0 = 0 = 0 = 0 = 0 = 0 = 0 | THIS DRAWING CONTAINS INFORMATION THAT IS PROPRIETARY TO MOLEX ELECTRONIC TECHNOLOGIES, LLC AND SHOULD NOT BE USED WITHOUT WRITTEN PERMISSION DIMENSION UNITS: MM ONLY SCALE: 3:1 GENERAL TOLERANCES (UNLESS SPECIFIED) ANGULAR TOL: ± 1.0° 4 PLACES ± 3 PLACES ± 2 PLACES ± 0.1 1 PLACE ± 0.2 0 PLACES ± DRAFT WHERE APPLICABLE MUST REMAIN WITHIN DIMENSIONS | CURRENT REV DESC: EC NO: 602373 DRWN: DSHETTY01 2018/05/25 CHK'D: MVANSLAMBROU 2018/10/04 APPR: MVANSLAMBROU 2018/10/04 INITIAL REVISION: DRWN: APROFFITT 2015/07/21 APPR: KDEKOSKI 2016/06/14 | MX150 BLADE SINGLE ROW SEALED ASSY MAT SEAL PRODUCT CUSTOMER DRAWING DOCUMENT NUMBER: SD-33481-0001 DOC TYPE: PSD DOC PART: 001 REVISION: A1 MATERIAL NUMBER: SEE NOTE 2a. CUSTOMER: GENERAL MARKET SHEET NUMBER: 3 OF 9 |
|----------------------------------------------------------------------------------------------------------------------------------------------------------------------------------------------------------------------------------------------------------------------------------------------------------------------------------------------------------------------------------------------------------------------------------------------------------------------------------------------------------------------------------------------------------------------------------------------------------------------------------------------------------------------------------------------------------------------------------------------------------------------------------------------------------------------------------------------------------------------------------------------------------------------------------------------------------------------------------------------------------------------------------------------------------------------------------------------------------------------------------------------------------------------------------------------------------------------------------------------------------------------------------------------------------------------------------------------------------------------------------------------------------------------------------------------------------------------------------------------------------------------------------------------------------------------------------------------------------------------------------------------------------------------------------------------------------------------------------------------------------------------------------------------------------------------------------------------------------------------------------------------------------------------------------------------------------------------------------------------------------------------------------------------------------------------------------------------------------------------------------------------------------------------------------------------------------------------------------------------------------------------------------------------------------------------------------------------------------------------------------------------------------------------------------------------------------------------------------------------------------------------------------------------------------------------------------------------------------------------------------------------------------------------------------------------------------------------------------------------------------------------------------------------------------------------------------------------------------------------------------------------------------------------------------------------------------------------------------------------------------------------------------------------------------------------------------------------------------------------------------------------------------------------------------------------------------------------------------------------------------------------------------------------------------------------------------------------------------------------------------------------------------------------------------------------------------------------------------------------------------------------------------------------------------------------------------------------------------------------------------------------------------------|---------------------------------------------------------------------------------------------------------------------------------------------------------------------------------------------------------------------------------------------------------------------------------------------------------------------------------------------------------------------------------------------------------------|-----------------------------------------------------------------------------------------------------------------------------------------------------------------------------------------------------------------------------|-------------------------------------------------------------------------------------------------------------------------------------------------------------------------------------------------------------------------------------------------------------------------------|

SHEET DESCRIPTION
KEY CONFIGURATIONS CONT.

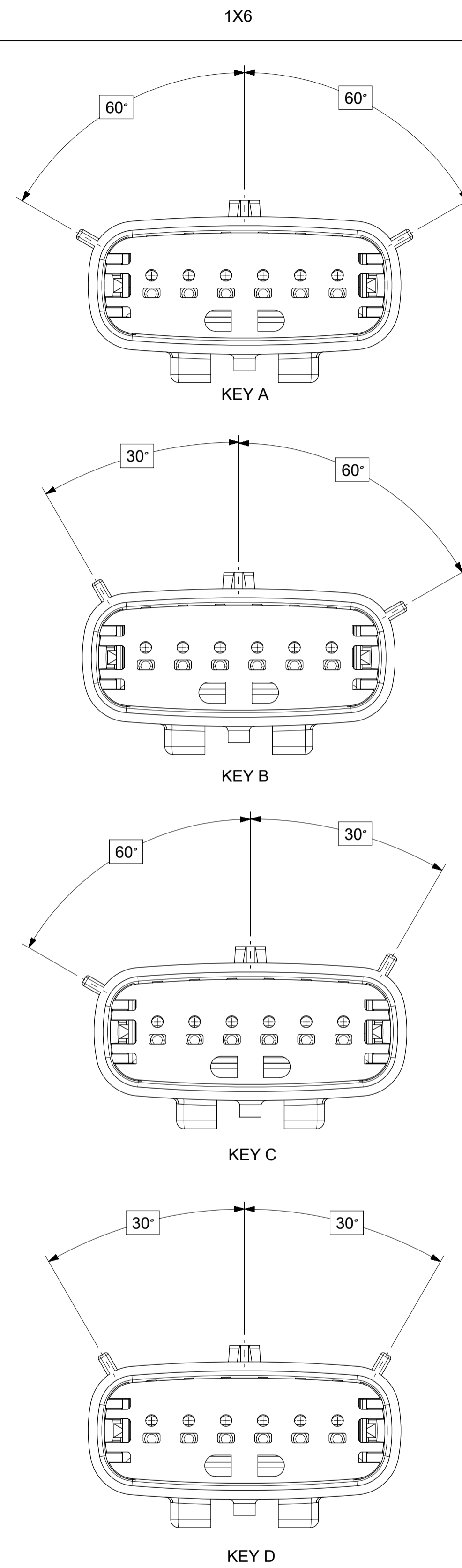

| | | | | | |
|-------------------------------------------------------------------------------|-------------------------------------------------------------------------------------------------------------------------------------------------------------------------------------------------------|-------------------------------------------------------------------------------------------------------------------------------------|-----------------------------------------------------------------------------------|--|--|
| SYMBOLS = 0 = 0 = 0 = 0 = 0 = 0 = 0 = 0 = 0 | THIS DRAWING CONTAINS INFORMATION THAT IS PROPRIETARY TO MOLEX ELECTRONIC TECHNOLOGIES, LLC AND SHOULD NOT BE USED WITHOUT WRITTEN PERMISSION DIMENSION UNITS: MM ONLY SCALE: 3:1 | CURRENT REV DESC: EC NO: 602373 DRWN: DSHETTY01 2018/05/25 CHK'D: MVANSLAMBROU 2018/10/04 APPR: MVANSLAMBROU 2018/10/04 | MX150 BLADE SINGLE ROW SEALED ASSY MAT SEAL | | |
| | GENERAL TOLERANCES (UNLESS SPECIFIED) ANGULAR TOL ± 1.0° 4 PLACES ± 3 PLACES ± 2 PLACES ± 0.1 1 PLACE ± 0.2 0 PLACES ± | INITIAL REVISION: DRWN: APROFFITT 2015/07/21 APPR: KDEKOSKI 2016/06/14 | | | |
| DRAFT WHERE APPLICABLE MUST REMAIN WITHIN DIMENSIONS | THIRD ANGLE PROJECTION | DRAWING: A1-SIZE SERIES: 33481 | MATERIAL NUMBER: SEE NOTE 2a. CUSTOMER: GENERAL MARKET SHEET NUMBER: 4 OF 9 | | |

SHEET DESCRIPTION
BACKSHELL

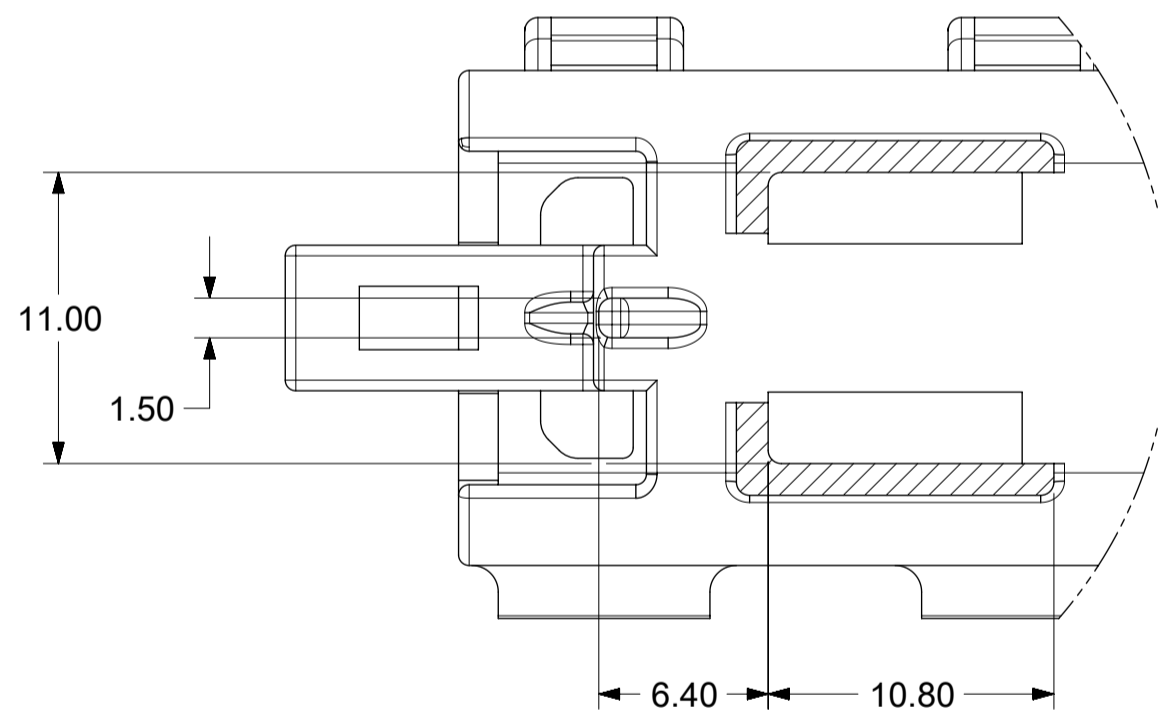
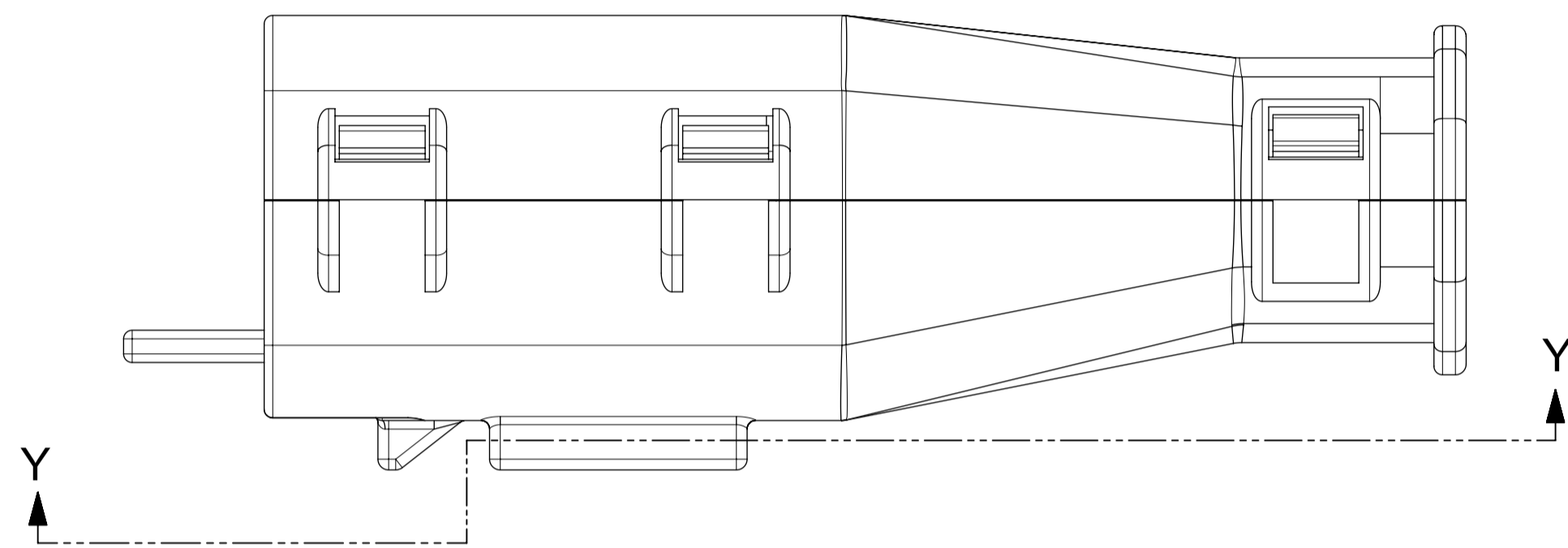
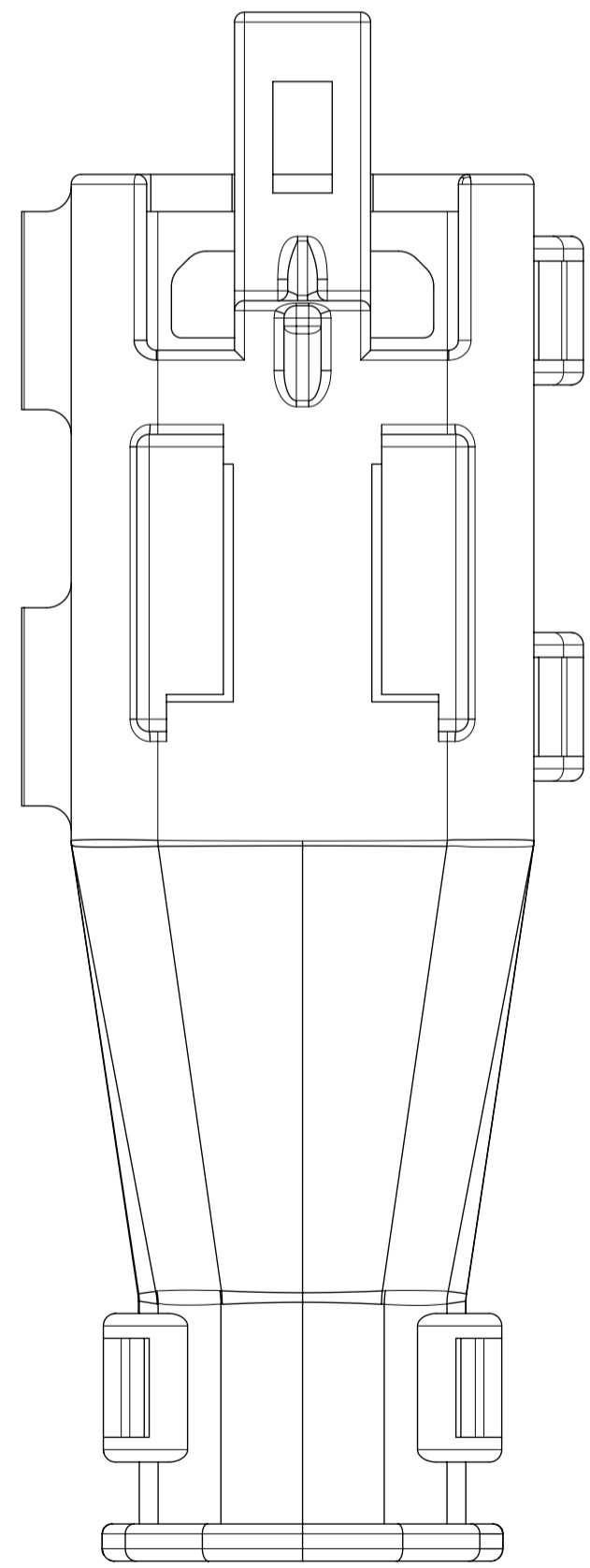
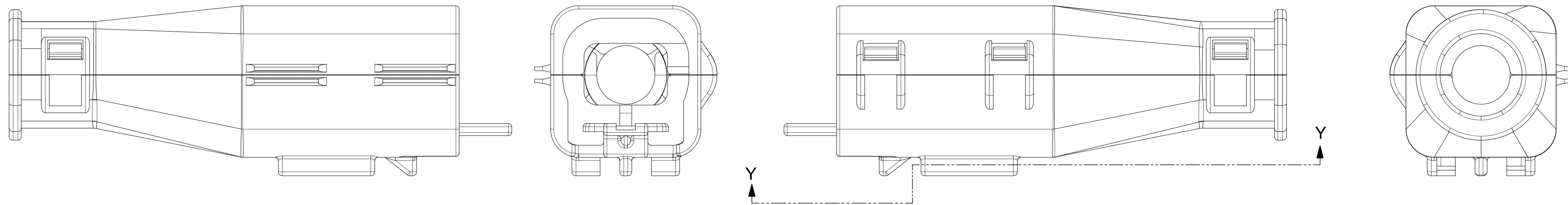

PARTIAL Y-Y
SCALE 3.5:1

| | | | | | |
|--------------------------------------------------------------------------------------|---------------------------------------------------------------------------------------------------------------------------------------------------------------------------------------------------------|-------------------------------------------------------------------------------------------------------------------------------------|----------------------------------------------------------------------------------------------------------------------------|-----------------------------------------------------------------------------------|--|
| SYMBOLS = 0 = 0 = 0 = 0 = 0 = 0 = 0 = 0 = 0 = 0 | THIS DRAWING CONTAINS INFORMATION THAT IS PROPRIETARY TO MOLEX ELECTRONIC TECHNOLOGIES, LLC AND SHOULD NOT BE USED WITHOUT WRITTEN PERMISSION DIMENSION UNITS: MM ONLY SCALE: 3.5:1 | CURRENT REV DESC: EC NO: 602373 DRWN: DSHETTY01 2018/05/25 CHK'D: MVANSLAMBROU 2018/10/04 APPR: MVANSLAMBROU 2018/10/04 | MX150 BLADE SINGLE ROW SEALED ASSY MAT SEAL | | |
| | GENERAL TOLERANCES (UNLESS SPECIFIED) ANGULAR TOL ± 1.0° 4 PLACES ± 3 PLACES ± 2 PLACES ± 0.1 1 PLACE ± 0.2 0 PLACES ± | INITIAL REVISION: DRWN: APROFFITT 2015/07/21 APPR: KDEKOSKI 2016/06/14 | PRODUCT CUSTOMER DRAWING DOCUMENT NUMBER: SD-33481-0001 DOC TYPE: PSD DOC PART: 001 REVISION: A1 | MATERIAL NUMBER: SEE NOTE 2a. CUSTOMER: GENERAL MARKET SHEET NUMBER: 8 OF 9 | |

SHEET DESCRIPTION
BACKSHELL CONFIGURATIONS

| CKT | BLADE CONFIGURATION | RECEPTACLE CONFIGURATION | DIMENSIONS | | | | |
|-----|---------------------|--------------------------|------------|-------|-------|-------|-------|
| | | | M | N | P | R | S |
| 1X2 | STANDARD | STANDARD | 107.84 | 29.50 | 27.00 | 26.25 | 25.00 |

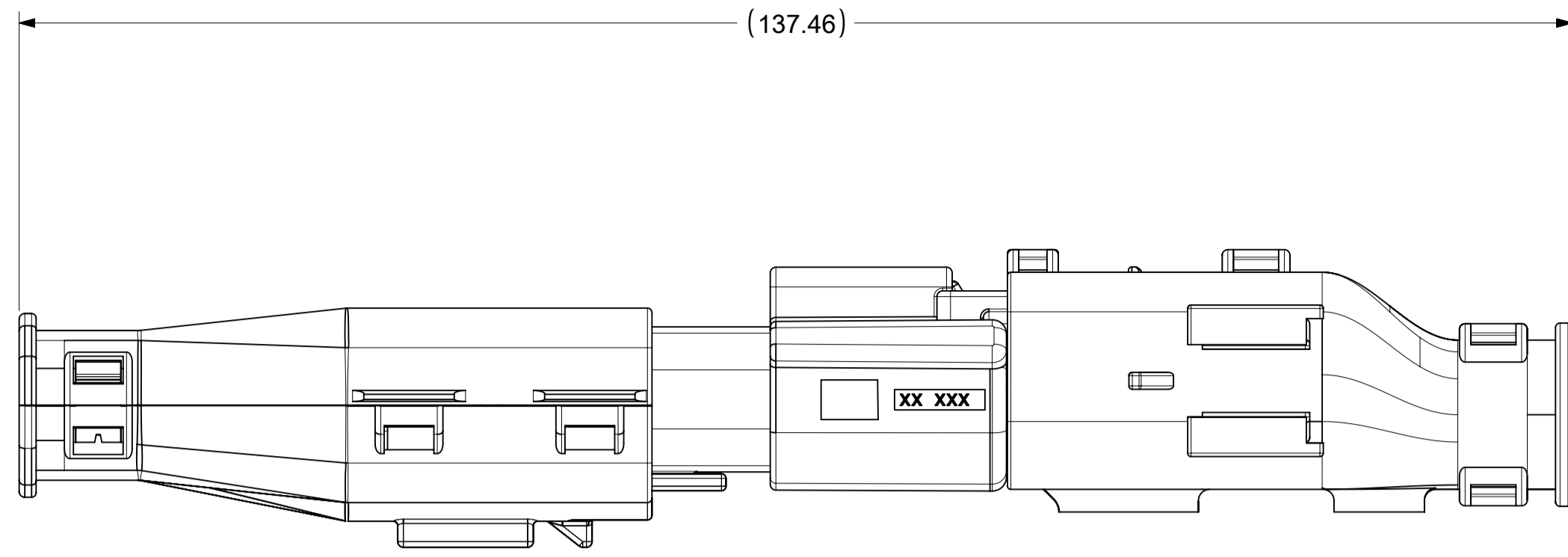

OVERALL MATED SYSTEM WITH BLADE AND RECEPTACLE BACKSHELL

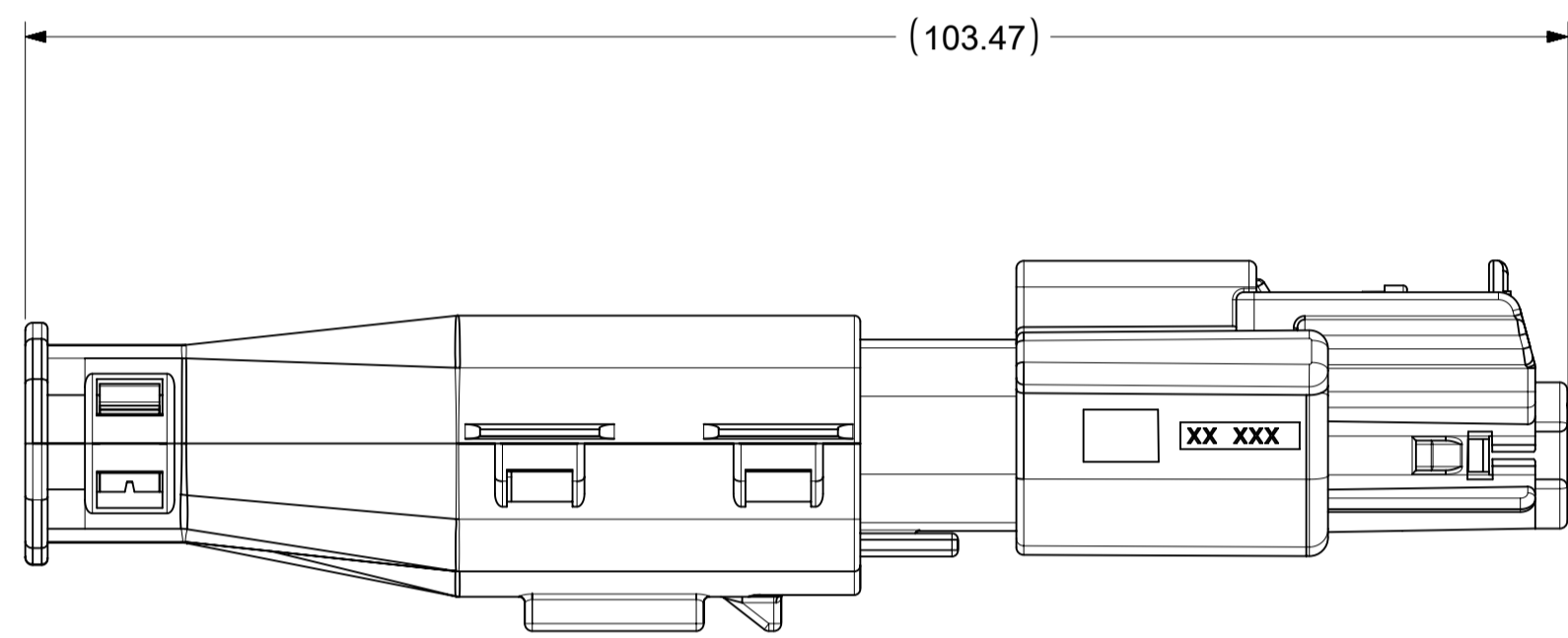
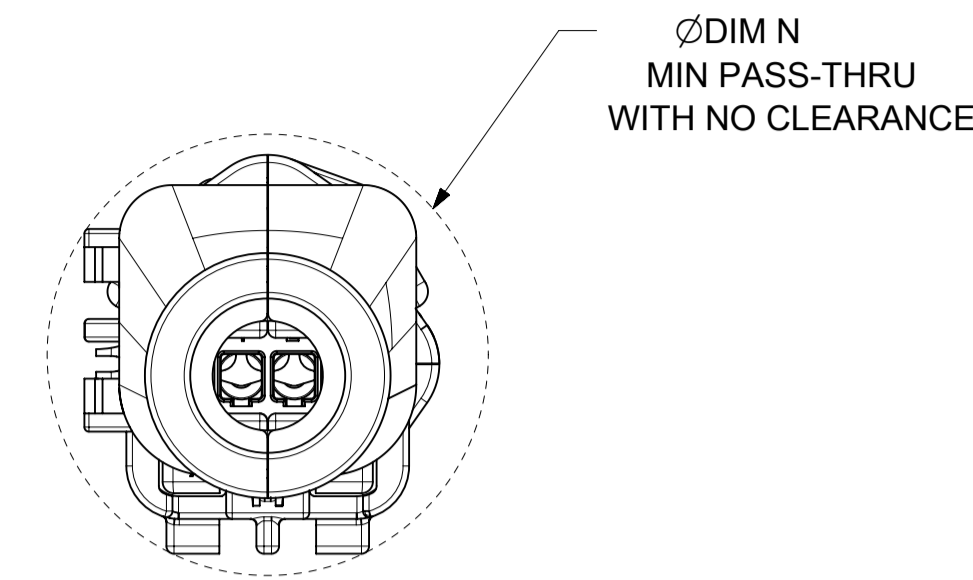

OVERALL MATED SYSTEM WITH BLADE BACKSHELL

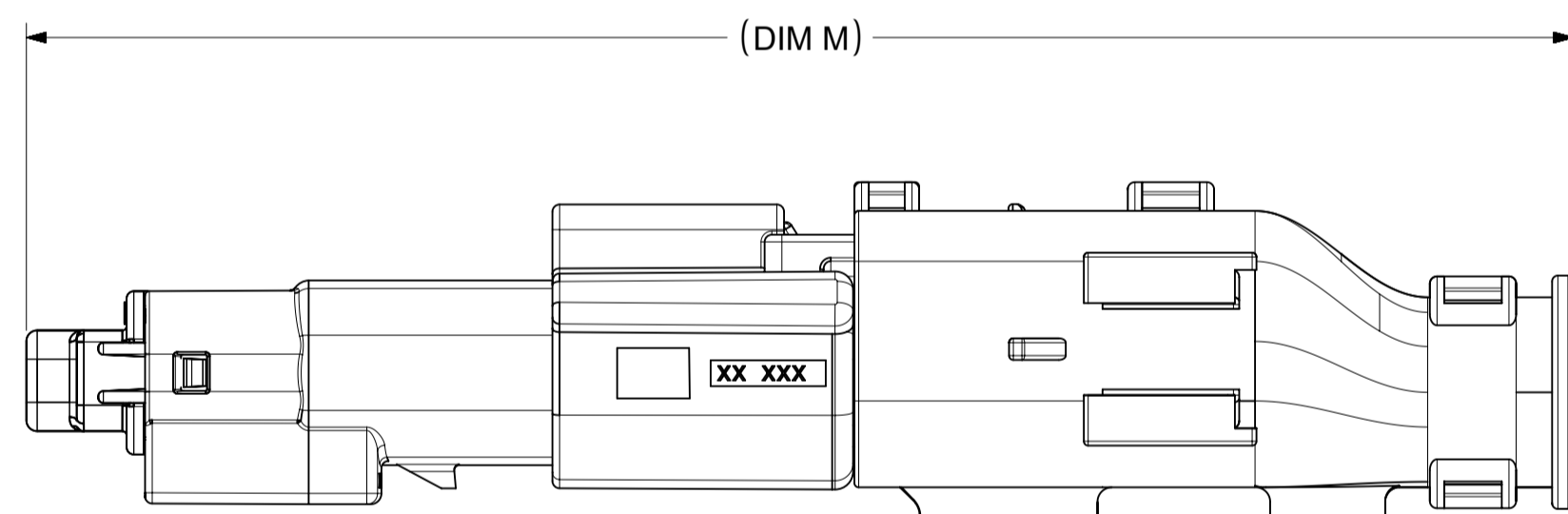
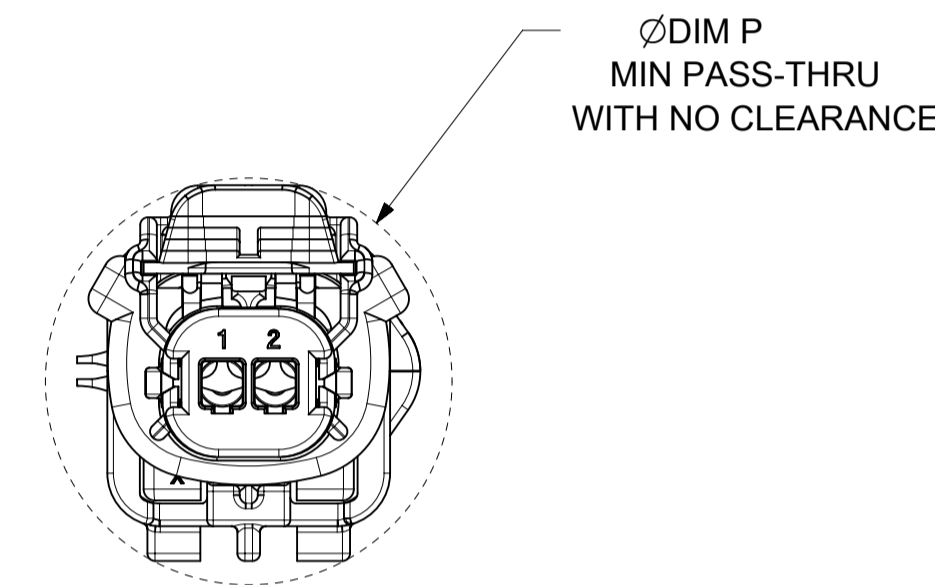

OVERALL MATED SYSTEM WITH RECEPTACLE BACKSHELL

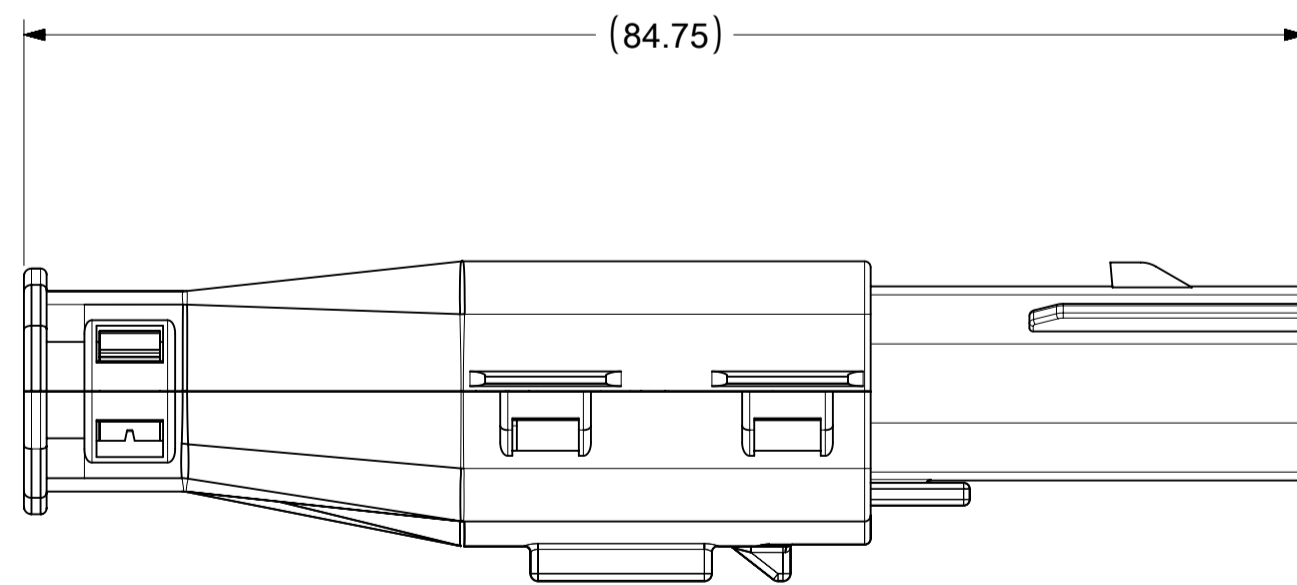
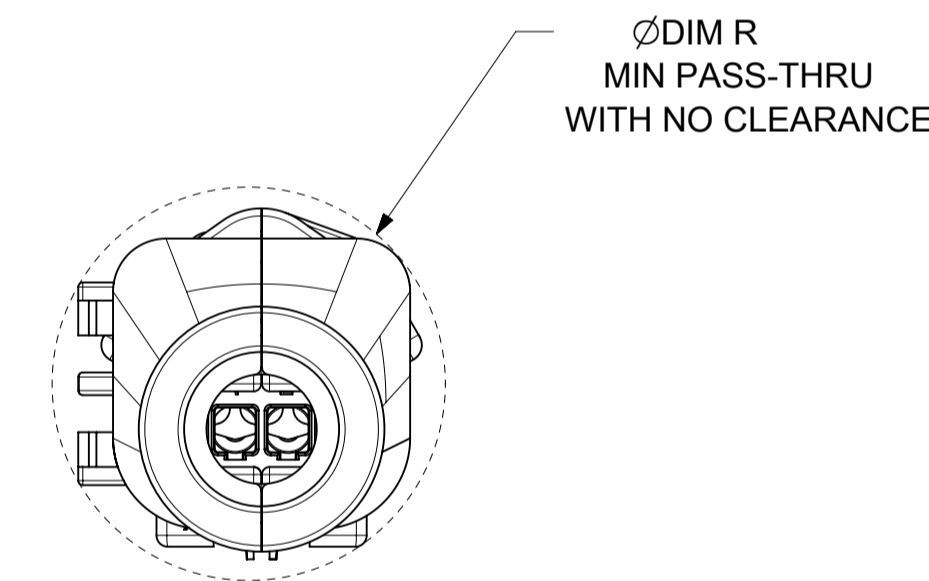

BLADE SEALED ASSEMBLY WITH BLADE BACKSHELL

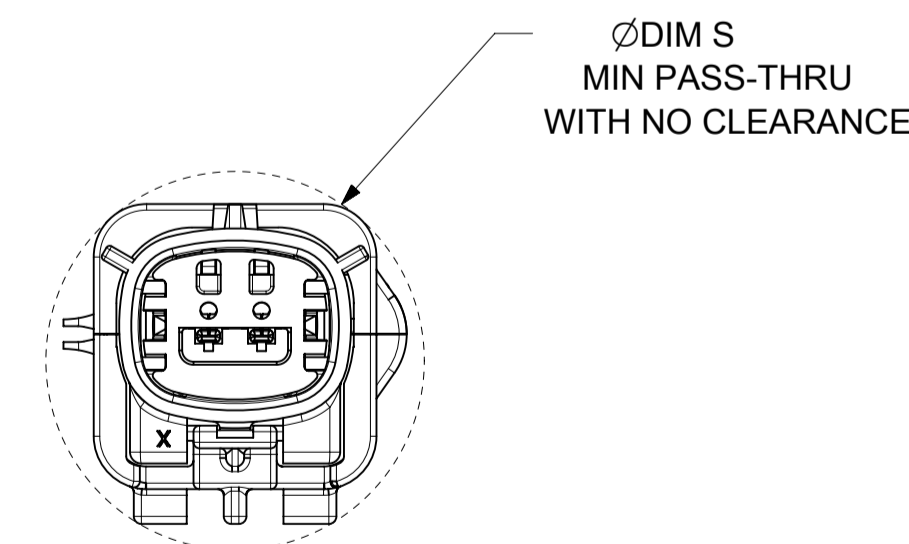

| | | | | | |
|--------------------------------------------------------------------------------------|-------------------------------------------------------------------------------------------------------------------------------------------------------------------------------------------------------|---------------------------------------------------------------------------------------------------------------------------------------------------------------------------------------------------------------------|----------------------------------------------------|-----------------------------------------------------------------------------------|--|
| SYMBOLS = 0 = 0 = 0 = 0 = 0 = 0 = 0 = 0 = 0 = 0 | THIS DRAWING CONTAINS INFORMATION THAT IS PROPRIETARY TO MOLEX ELECTRONIC TECHNOLOGIES, LLC AND SHOULD NOT BE USED WITHOUT WRITTEN PERMISSION DIMENSION UNITS: MM ONLY SCALE: 2:1 | CURRENT REV DESC: EC NO: 602373 DRWN: DSHETTY01 2018/05/25 CHK'D: MVANSLAMBROU 2018/10/04 APPR: MVANSLAMBROU 2018/10/04 INITIAL REVISION: DRWN: APROFFITT 2015/07/21 APPR: KDEKOSKI 2016/06/14 | MX150 BLADE SINGLE ROW SEALED ASSY MAT SEAL | | |
| | GENERAL TOLERANCES (UNLESS SPECIFIED) ANGULAR TOL ± 1.0° 4 PLACES ± 3 PLACES ± 2 PLACES ± 0.1 1 PLACE ± 0.2 0 PLACES ± DRAFT WHERE APPLICABLE MUST REMAIN WITHIN DIMENSIONS | PRODUCT CUSTOMER DRAWING DOCUMENT NUMBER: SD-33481-0001 DOC TYPE: PSD DOC PART: 001 REVISION: A1 | | MATERIAL NUMBER: SEE NOTE 2a. CUSTOMER: GENERAL MARKET SHEET NUMBER: 9 OF 9 | |

TABLE OF CONTENTS

| SHEET NO. | SHEET DESCRIPTION |
|-----------|-----------------------|
| 1 | NOTES |
| 2 | KEY CONFIGURATIONS |
| 3 | BLADE SEALED ASSEMBLY |
| 4 | SYSTEM PACKAGING |
| 5 | BOM |

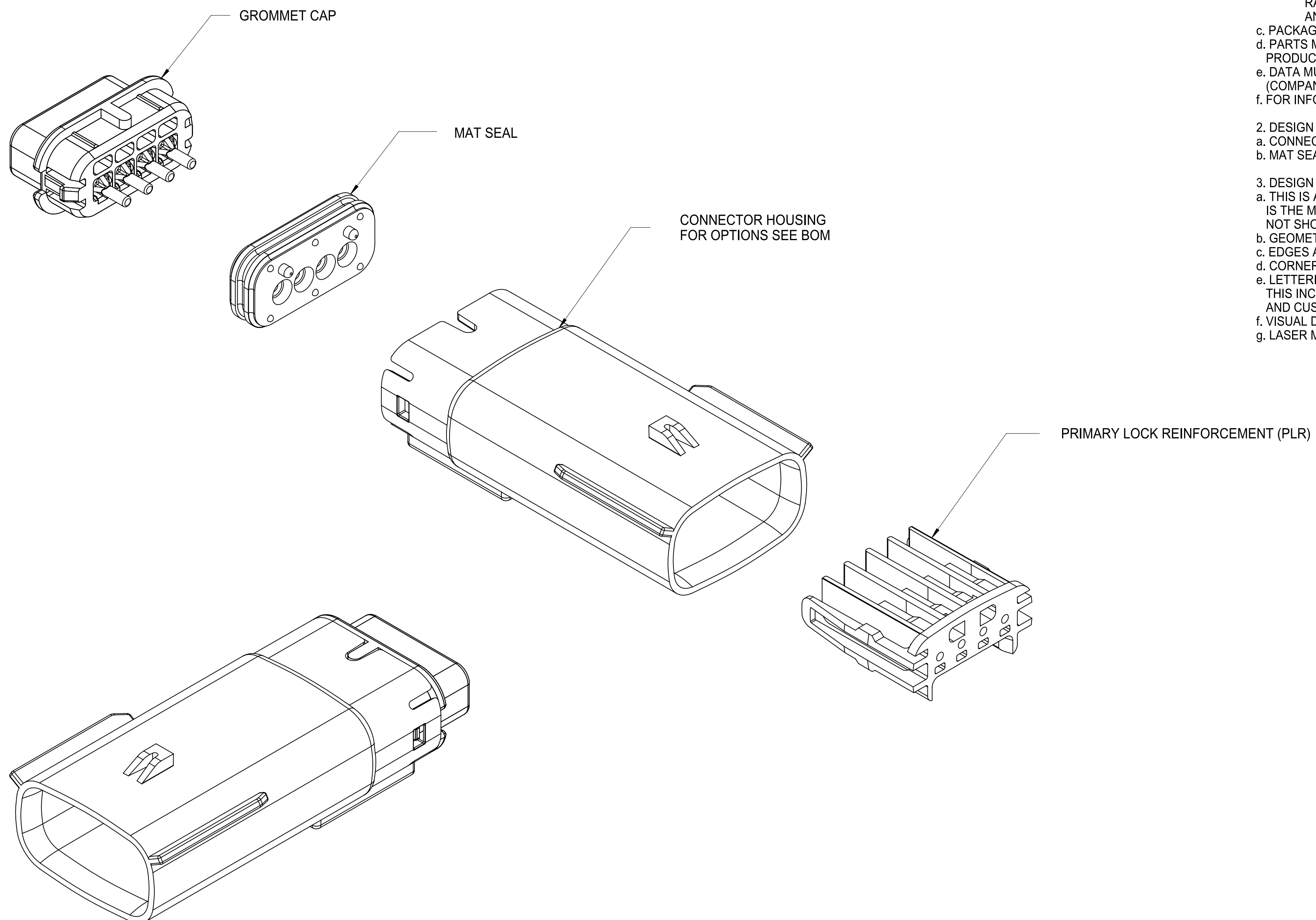

NOTES: VALID UNLESS OTHERWISE SPECIFIED

1. GENERAL:
 - a. APPLICATION SPECIFICATION SEE: AS-33472-100
CONTAINS: PRODUCT INTRODUCTION, PRODUCT SUMMARY, CONNECTOR ASSEMBLY, PACKAGING INFORMATION, CONNECTOR MATING, SERVICE INSTRUCTIONS, ELECTRICAL CONTINUITY CHECKING, CRIMPING, AND TROUBLESHOOTING.
-DESIGNED TO MATE WITH RECEPTACLE SEALED ASSEMBLY SPECIFIED IN MOLEX DRAWING SD-33471-041.
-FOR 1.5mm BLADE TERMINALS TO BE USED WITH THIS ASSEMBLY SEE MOLEX DRAWING SD-33000-001.
- SYSTEM TO BE USED WITH WIRE WITHIN DIAMETER RANGE OF 1.2mm TO 2.69mm.
-ASSEMBLY SHIPPED WITH PLR IN PRE-LOCK POSITION
-IN THE EVENT THAT THE PLR IS FOUND IN THE SEATED (FINAL LOCK) POSITION, REFER TO MOLEX SPECIFICATION PS-34646-001, AVAILABLE AT www.molex.com <<http://www.molex.com>>
-ASSEMBLY CONFORMS TO SAE/USCAR-2 REV.4 WITH THE FOLLOWING EXCEPTIONS:
TERMINAL INSERTION FORCE FOR WIRE DIAMETER ABOVE 2.5mm NOT EXCEEDING 2.69mm SHALL NOT EXCEED 45 NEWTONS.
 - b. PRODUCT SPECIFICATION SEE: PS-33471-000
CONTAINS: PRODUCT INTRODUCTION, PRODUCT SUMMARY, RATINGS (CURRENT, TEMPERATURE, SEALING, AND FLAMMABILITY), AND PRODUCT VALIDATION.
 - c. PACKAGING SPECIFICATION PER MOLEX DRAWING: PK-31300-635
d. PARTS MUST BE IN COMPLIANCE TO MOLEX CHEMICAL SUBSTANCES FOR PRODUCTS AND PACKAGING SPECIFICATION: ES-40000-5016
 - e. DATA MUST BE SUBMITTED UNDER THE MOLEX PART NUMBER TO IMDS (COMPANY ID#13255)
 - f. FOR INFORMATION ON 1X4 BLADE SEALED ASSEMBLY WITH SHORTING BAR SEE SD-31280-200.
2. DESIGN - MATERIALS:
 - a. CONNECTOR HOUSING, GROMMET CAP, PLR: SPS/NYLON BLENDED 20% GLASS FILLED
 - b. MAT SEAL: INHERENTLY LUBRICATED SILICONE
3. DESIGN - GEOMETRY:
 - a. THIS IS A 100% CAD GENERATED PART. THE CAD MATHEMATICAL DATA IS THE MASTER FOR THIS PART. FOR DIMENSIONAL OR ANY INFORMATION NOT SHOWN ON THIS DRAWING, ANALYZE THE CAD MODEL.
 - b. GEOMETRIC DIMENSIONS AND TOLERANCES PER ASME Y14.5M - 1994
 - c. EDGES AND UNDIMENSIONED DETAILS PER ISO13715
 - d. CORNERS SHOWN AS SHARP TO BE R 0.2 MAX.
 - e. LETTERING SHALL BE 0.15 MAX RAISED IN 0.25 MAX RECESS PAD. THIS INCLUDES RECYCLING CODE, CAVITY ID, VENDOR IDENTIFICATION, AND CUSTOMER MATERIAL NUMBER.
 - f. VISUAL DEFECTS SHALL MEET COSMETIC STANDARD PS-45499-002 (Class B)
 - g. LASER MARKING: TBD

| | |
|-------|---------------------------------------------------------------------------------------------------------------------------------------------------------------------------------------------------------------------------------------------------------------|
| W4 | UPDATED THE STATUS OF P/NS ON SHEET 5 33481-04XX) TO OBSOLETE PER PCN 512135 ADDED SALEABLE STATUS OF P/NS (33481-44XX) ON SHEET 5 P/NS 334814408 THRU 334814409 AND 334814412 THRU 334814412 WHICH HAVE BEEN MARKED NOT RECOMMENDED IN THE COMMENTS |
| REV # | DESCRIPTION |

| | | | | | | | | | |
|-----------------------------------------------------------------------------------------------------------------------------------------------|-------|----------------------------------------|--|--------|---------------------------------------------------------------------------------|--|--|--|--|
| THIS DRAWING CONTAINS INFORMATION THAT IS PROPRIETARY TO MOLEX ELECTRONIC TECHNOLOGIES, LLC AND SHOULD NOT BE USED WITHOUT WRITTEN PERMISSION | | | | | | | | | |
| DIMENSION UNITS | SCALE | CURRENT REV DESC: UPDATED PARTS STATUS | | | | | | | |
| mm | 3:1 | | | | | | | | |
| GENERAL TOLERANCES (UNLESS SPECIFIED) | | EC NO: CO-000001228 | | | MX150 1X4 BLADE SEALED ASSEMBLY MAT SEAL PRODUCT SALES DRAWING | | | | |
| ANGULAR TOL | ± 3° | DRWN: MattYoung 21-Jul-2022 | | | | | | | |
| 4 PLACES | ± 0 | CHK'D: Joe Fox 01-Aug-2022 | | | DOCUMENT NUMBER: SD-33481-041 DOC TYPE: PSD DOC PART: 001 REVISION: W4 | | | | |
| 3 PLACES | ± 0 | APPR: Katy Boruszewski 02-Aug-2022 | | | | | | | |
| 2 PLACES | ± 0.1 | INITIAL REVISION: | | | MATERIAL NUMBER: 33481 CUSTOMER: GENERAL MARKET SHEET NUMBER: 1 OF 5 | | | | |
| 1 PLACE | ± 0.3 | DRWN: RFC_PLMIMP | | | | | | | |
| 0 PLACES | ± 0 | APPR: | | | DRAFT WHERE APPLICABLE MUST REMAIN WITHIN DIMENSIONS | | | | |
| THIRD ANGLE PROJECTION | | DRAWING | | SERIES | | | | | |
| | | D-SIZE | | 33481 | | | | | |

KEY CONFIGURATIONS

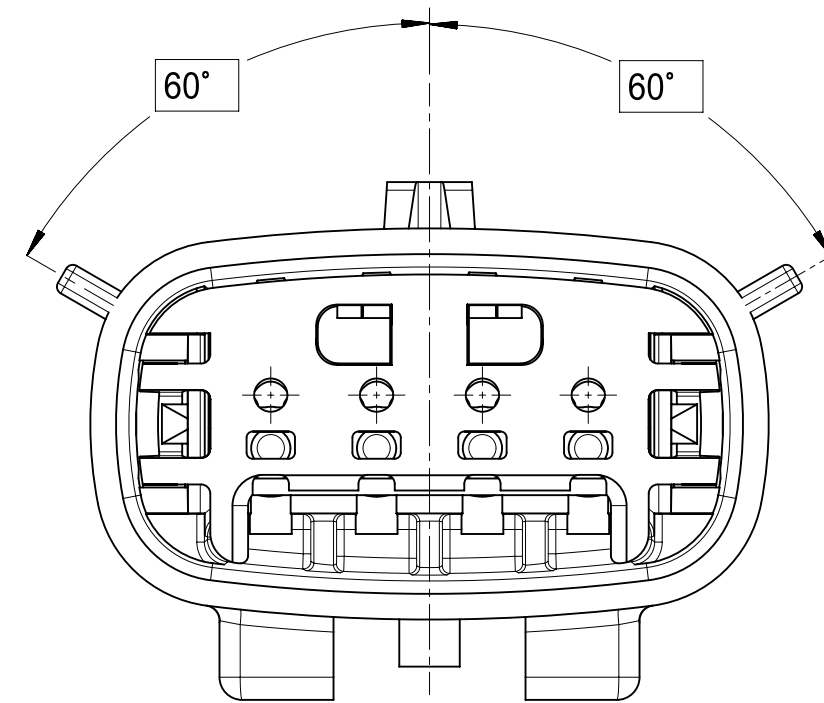

KEY A

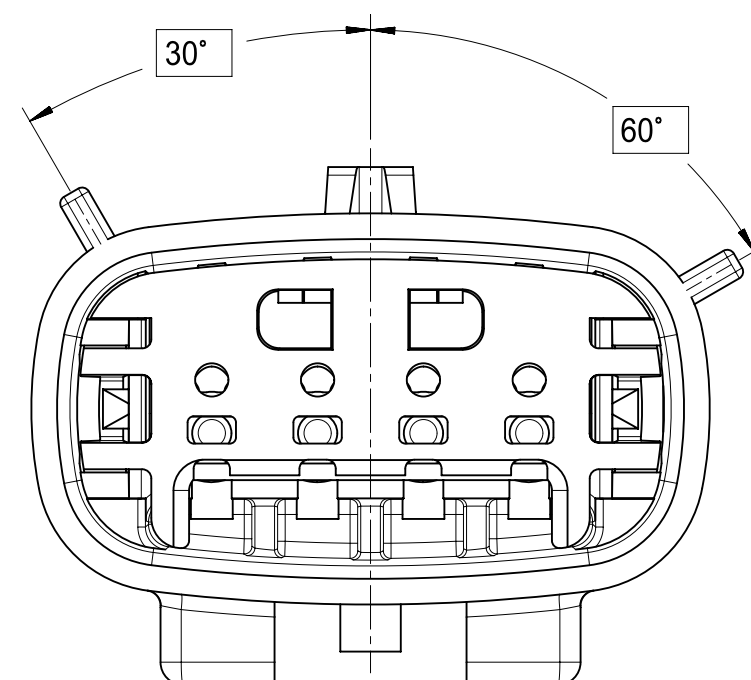

KEY B

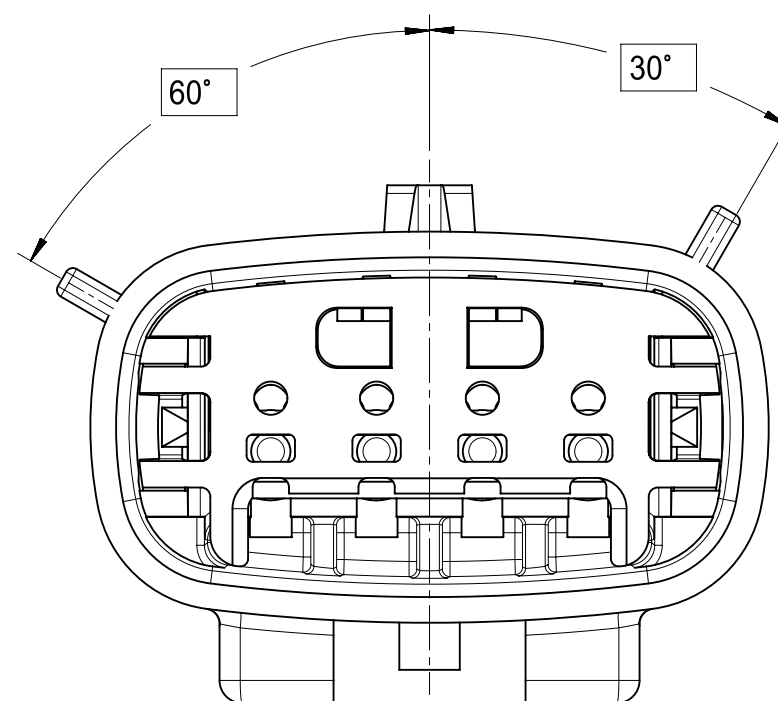

KEY C

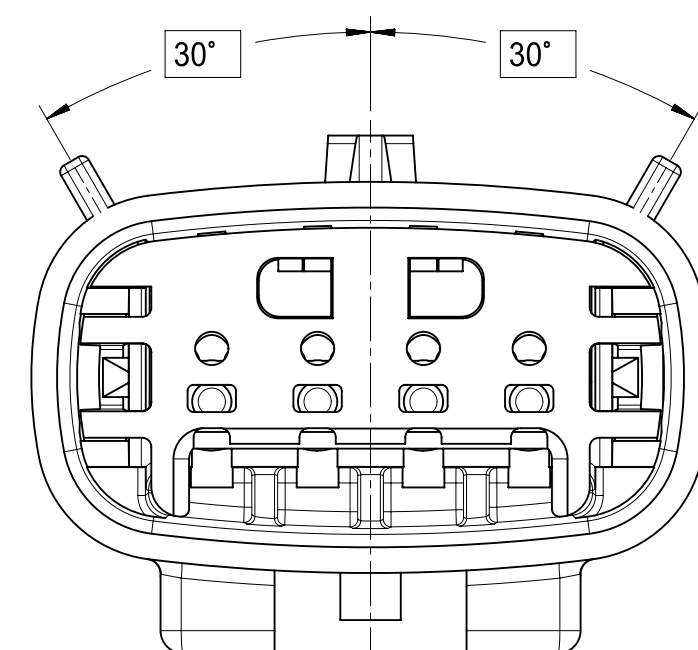

KEY D

THIS DRAWING CONTAINS INFORMATION THAT IS PROPRIETARY TO MOLEX ELECTRONIC TECHNOLOGIES, LLC AND SHOULD NOT BE USED WITHOUT WRITTEN PERMISSION

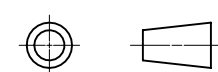
| | | | | | | | |
|---------------------------------------------------------------------------------------|-------|----------------------------------------|--|---------------------------------------------------------------------------------------|--|--------------------------------|--|
| DIMENSION UNITS | SCALE | CURRENT REV DESC: UPDATED PARTS STATUS | |  | | | |
| mm | 4:1 | | | | | | |
| GENERAL TOLERANCES (UNLESS SPECIFIED) | | | | MX150 1X4 BLADE SEALED ASSEMBLY MAT SEAL | | | |
| ANGULAR TOL ± 3° | | | | PRODUCT SALES DRAWING | | | |
| 4 PLACES ± 0 | | | | EC NO: CO-000001228 | | DOCUMENT NUMBER | |
| 3 PLACES ± 0 | | | | DRWN: MattYoung 21-Jul-2022 | | SD-33481-041 | |
| 2 PLACES ± 0.1 | | | | CHK'D: Joe Fox 01-Aug-2022 | | DOC TYPE DOC PART REVISION | |
| 1 PLACE ± 0.3 | | | | APPR: Katy Boruszewski 02-Aug-2022 | | PSD 001 W4 | |
| 0 PLACES ± 0 | | | | INITIAL REVISION: | | | |
| DRAFT WHERE APPLICABLE MUST REMAIN WITHIN DIMENSIONS | | | | DRWN: RFC_PLMIMP | | MATERIAL NUMBER | |
| THIRD ANGLE PROJECTION | | DRAWING | | SERIES | | CUSTOMER | |
|  | | D-SIZE | | 33481 | | GENERAL MARKET | |
| | | | | SHEET NUMBER | | 2 OF 5 | |

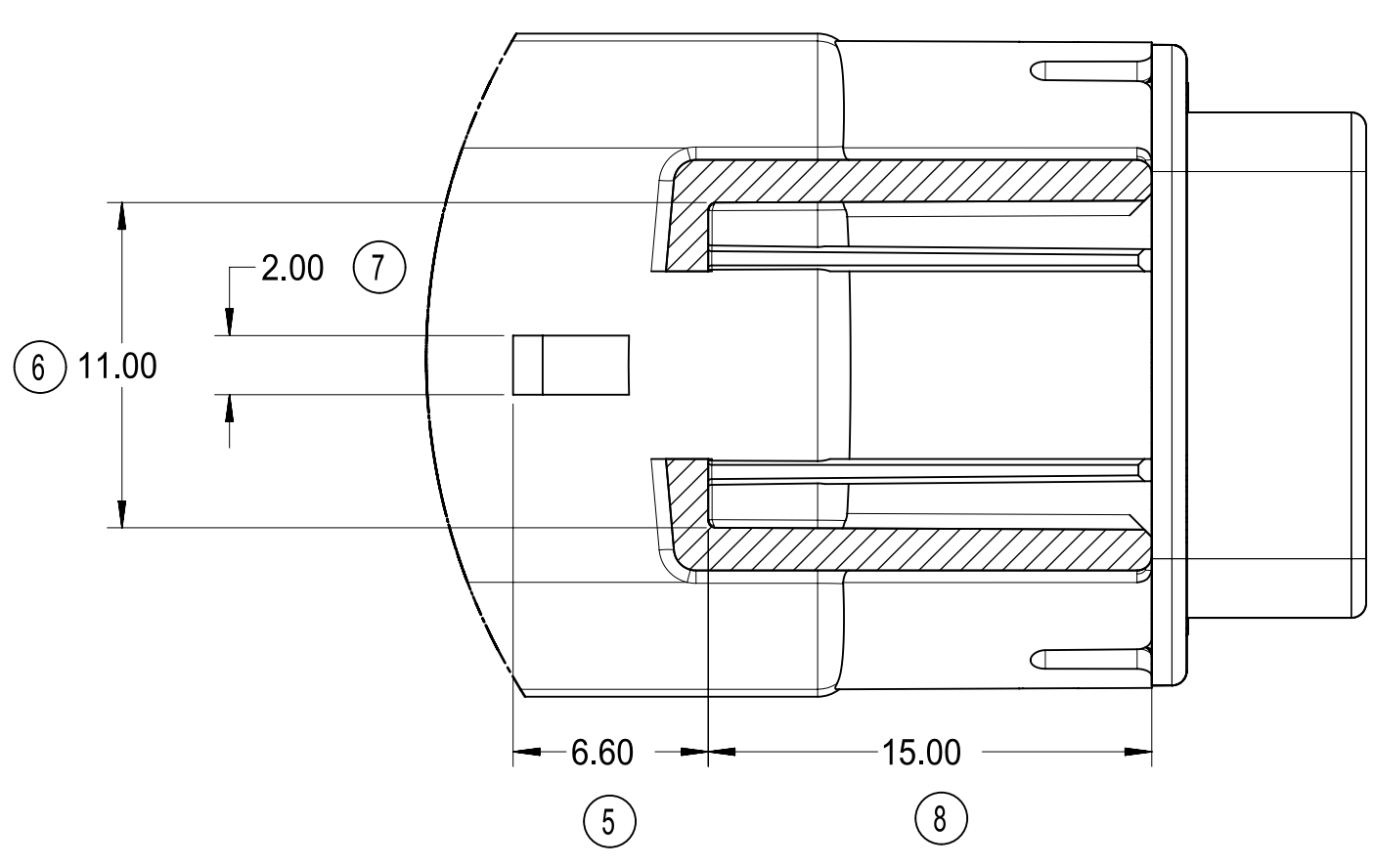
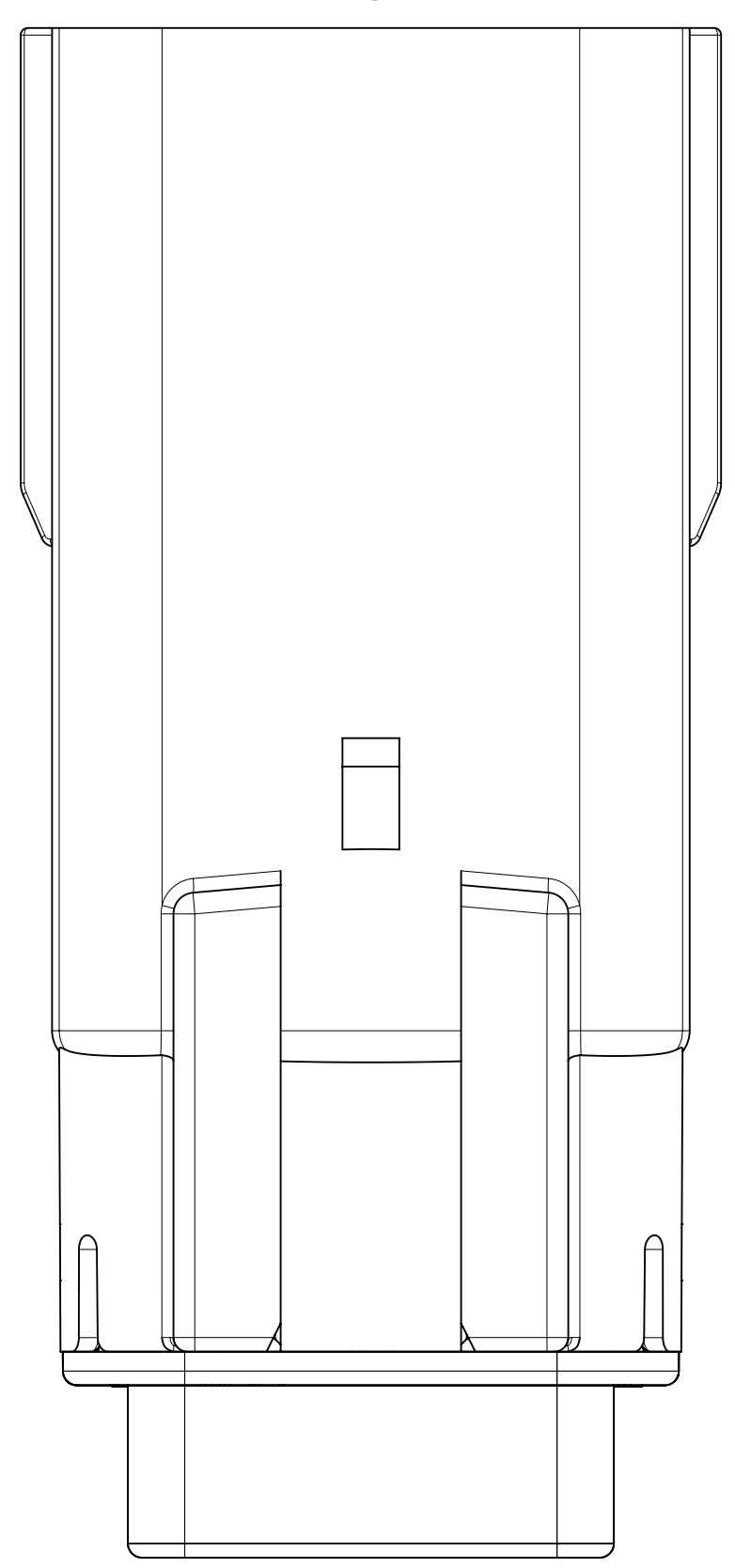
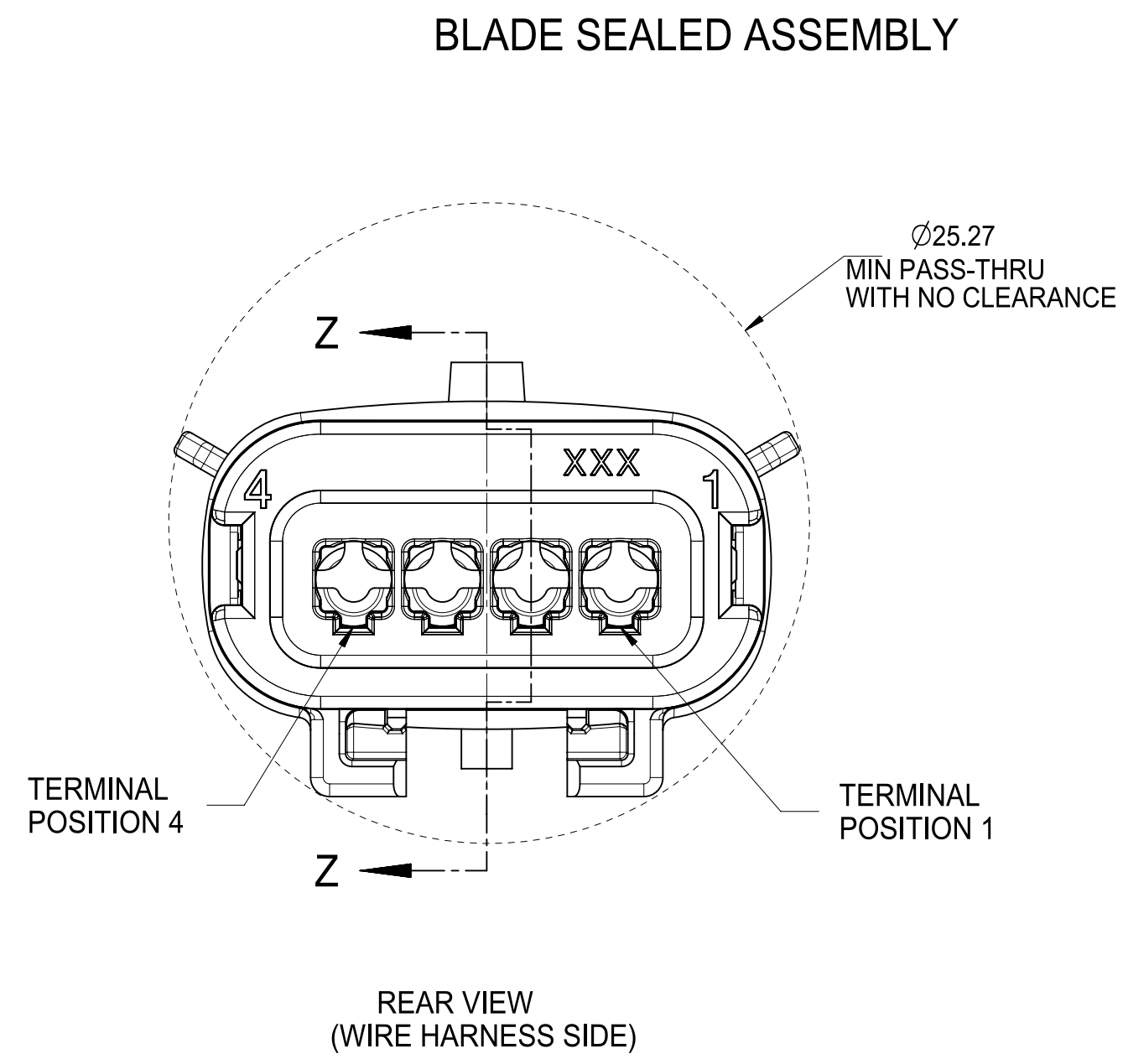
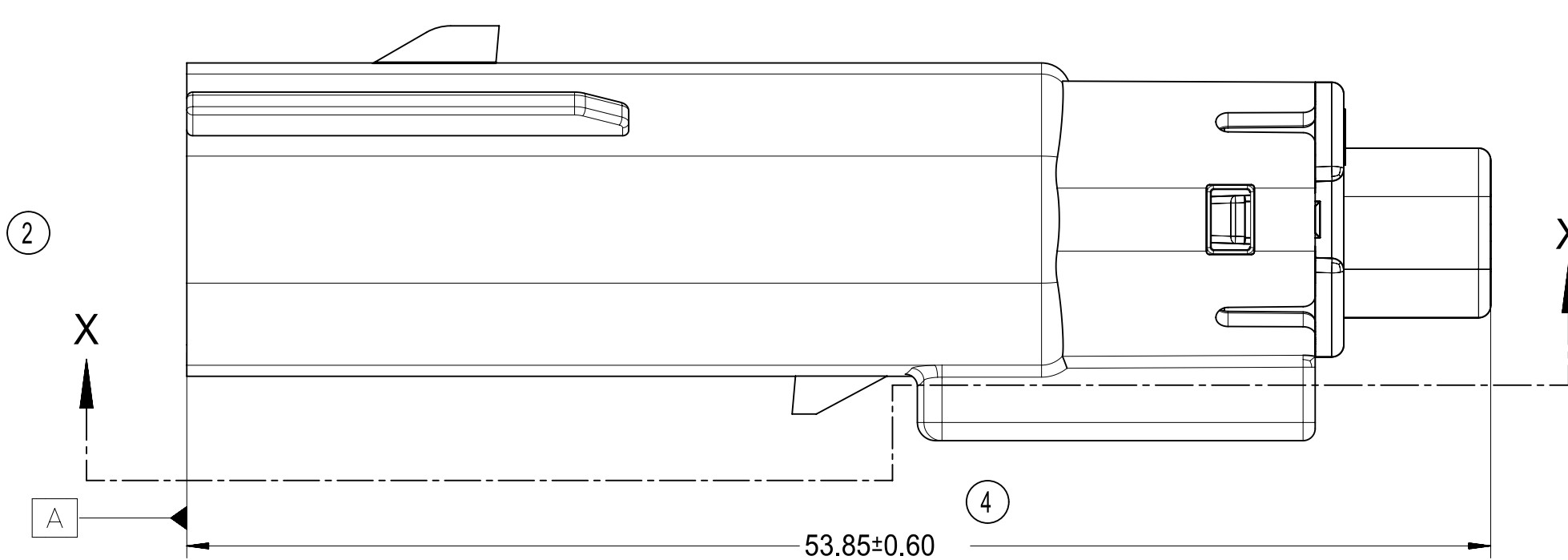
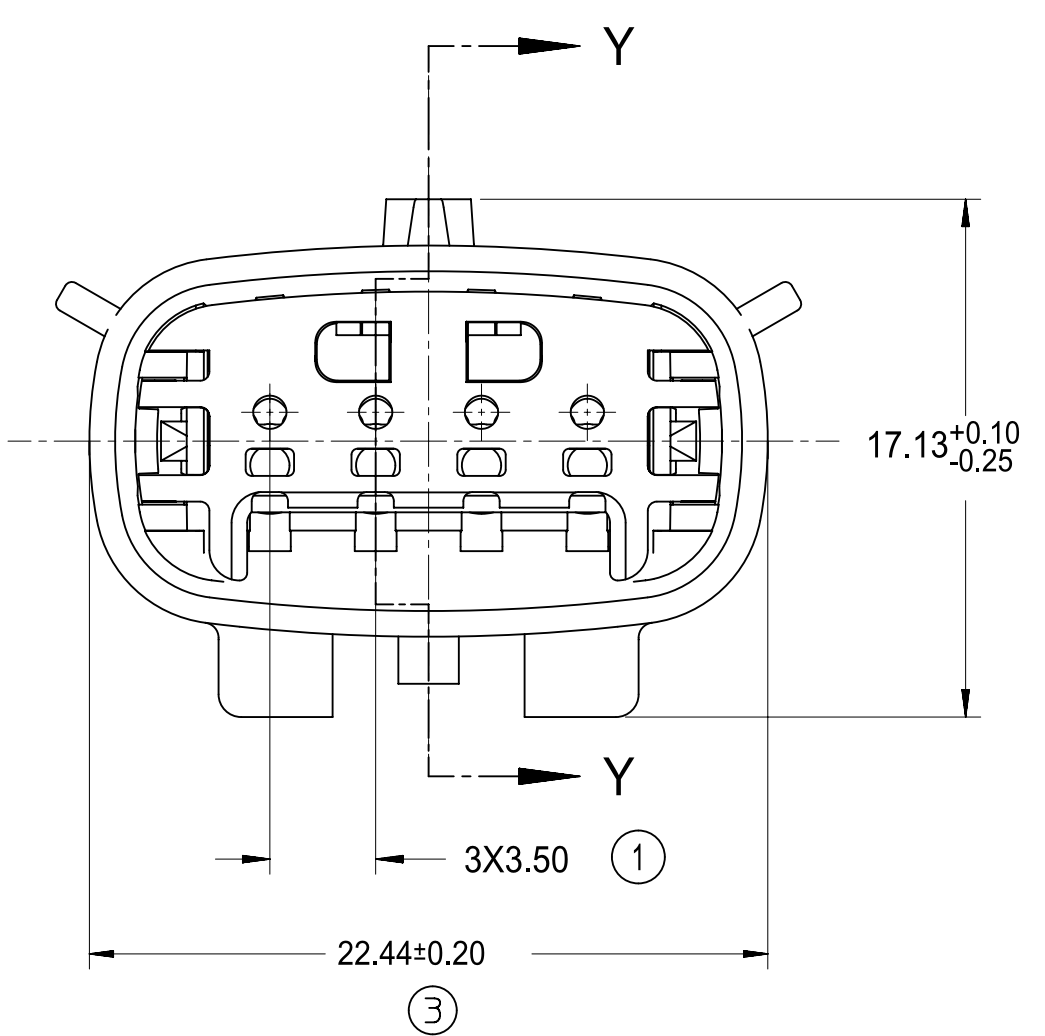
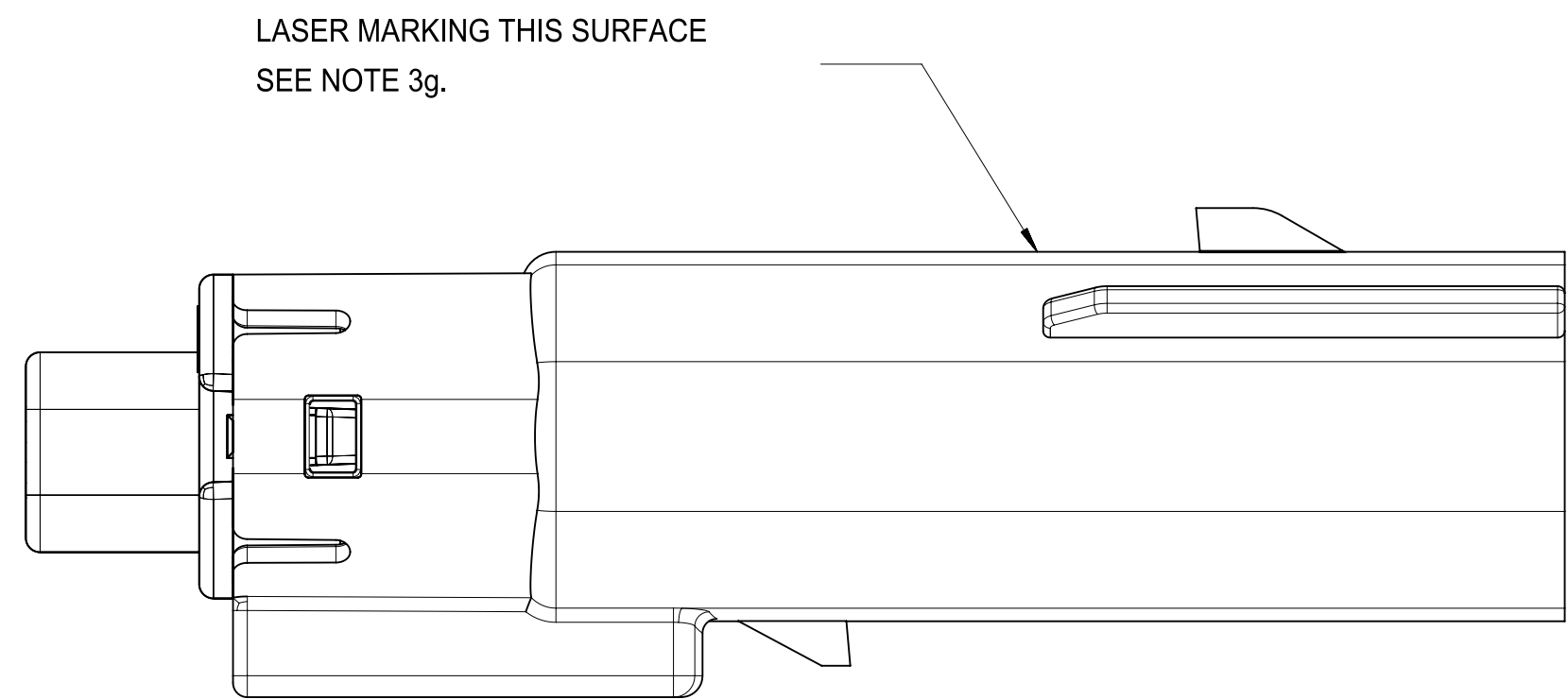

PARTIAL X-X
SCALE 4:1

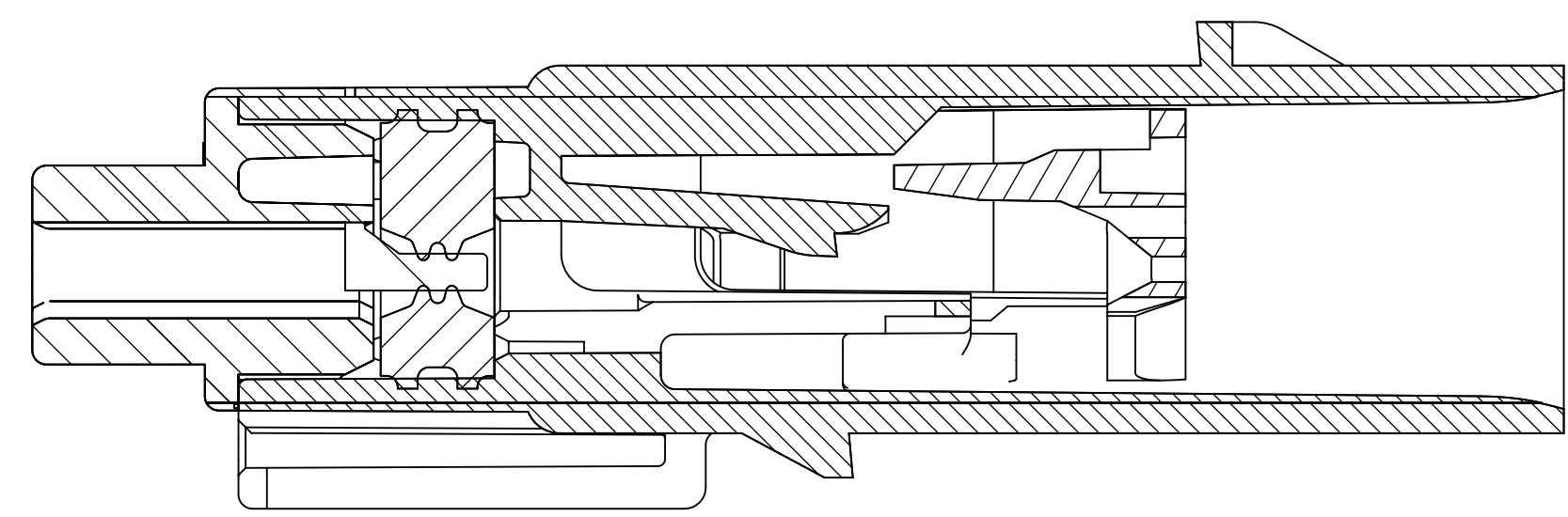

PRIMARY LOCK REINFORCEMENT (PLR) SHOWN
IN PRE-STAGED POSITION

SECTION Z-Z

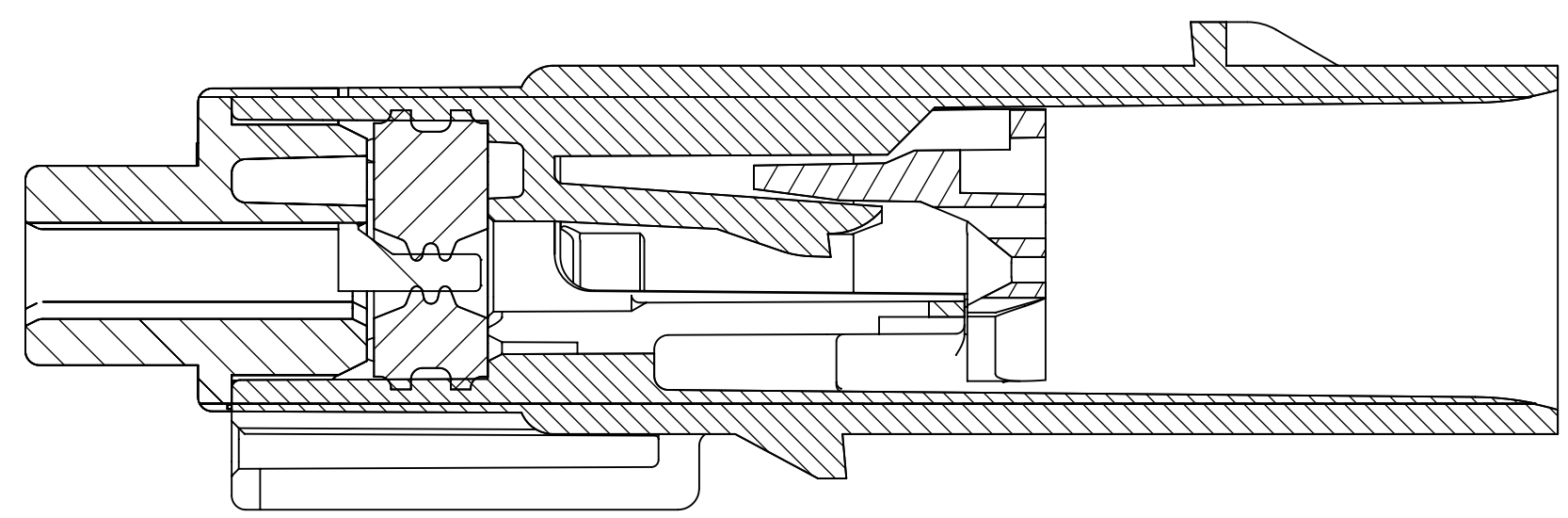

PRIMARY LOCK REINFORCEMENT (PLR) SHOWN
IN FINAL-LOCK POSITION

SECTION Y-Y

| | | | | | | | | | |
|-----------------------------------------------------------------------------------------------------------------------------------------------|--|---------------------|----------------------------|-------------------------------------------|--------------------------|-------------|-----------------------------------|--|----------------------------------------|
| THIS DRAWING CONTAINS INFORMATION THAT IS PROPRIETARY TO MOLEX ELECTRONIC TECHNOLOGIES, LLC AND SHOULD NOT BE USED WITHOUT WRITTEN PERMISSION | | | | | | | | | |
| DIMENSION UNITS mm | | SCALE 4:1 | | CURRENT REV DESC: UPDATED PARTS STATUS | | | | | |
| GENERAL TOLERANCES (UNLESS SPECIFIED) | | | | EC NO: CO-000001228 | | | | | |
| ANGULAR TOL ± 3° | | | | DRWN: MattYoung | | 21-Jul-2022 | | | |
| 4 PLACES ± 0 | | | | CHK'D: Joe Fox | | 01-Aug-2022 | | | |
| 3 PLACES ± 0 | | | | APPR: Katy Boruszewski | | 02-Aug-2022 | | | |
| 2 PLACES ± 0.1 | | | | INITIAL REVISION: | | | | | |
| 1 PLACE ± 0.3 | | | | DRWN: RFC_PLMIMP | | | | | |
| 0 PLACES ± 0 | | | | APPR: | | | | | |
| DRAFT WHERE APPLICABLE MUST REMAIN WITHIN DIMENSIONS | | | THIRD ANGLE PROJECTION | | DRAWING D-SIZE | | SERIES 33481 | | DOCUMENT NUMBER SD-33481-041 |
| | | | | | MATERIAL NUMBER | | CUSTOMER GENERAL MARKET | | DOC TYPE PSD |
| | | | | | | | DOC PART 001 | | REVISION W4 |
| | | | | | | | SHEET NUMBER 3 OF 5 | | |

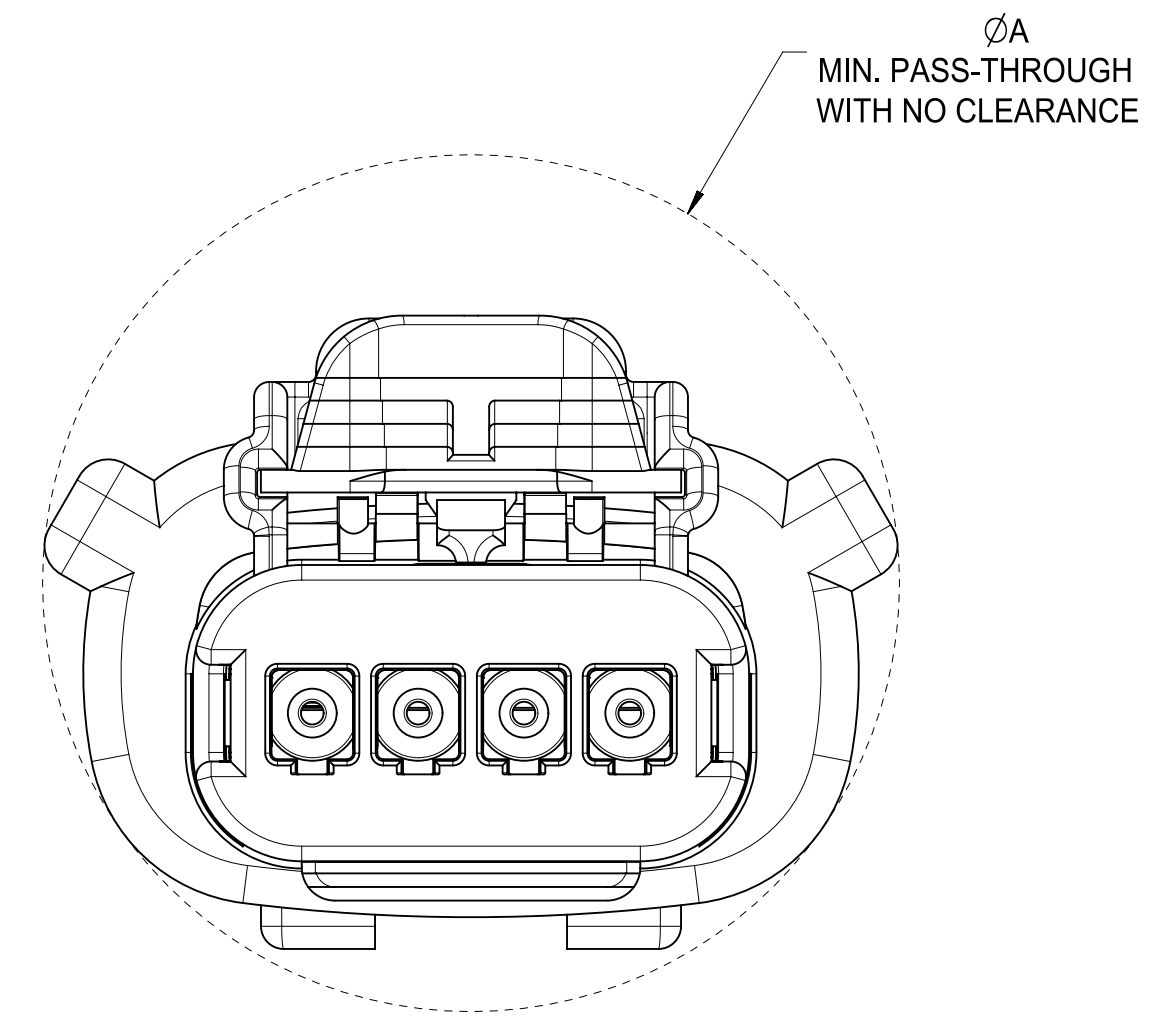
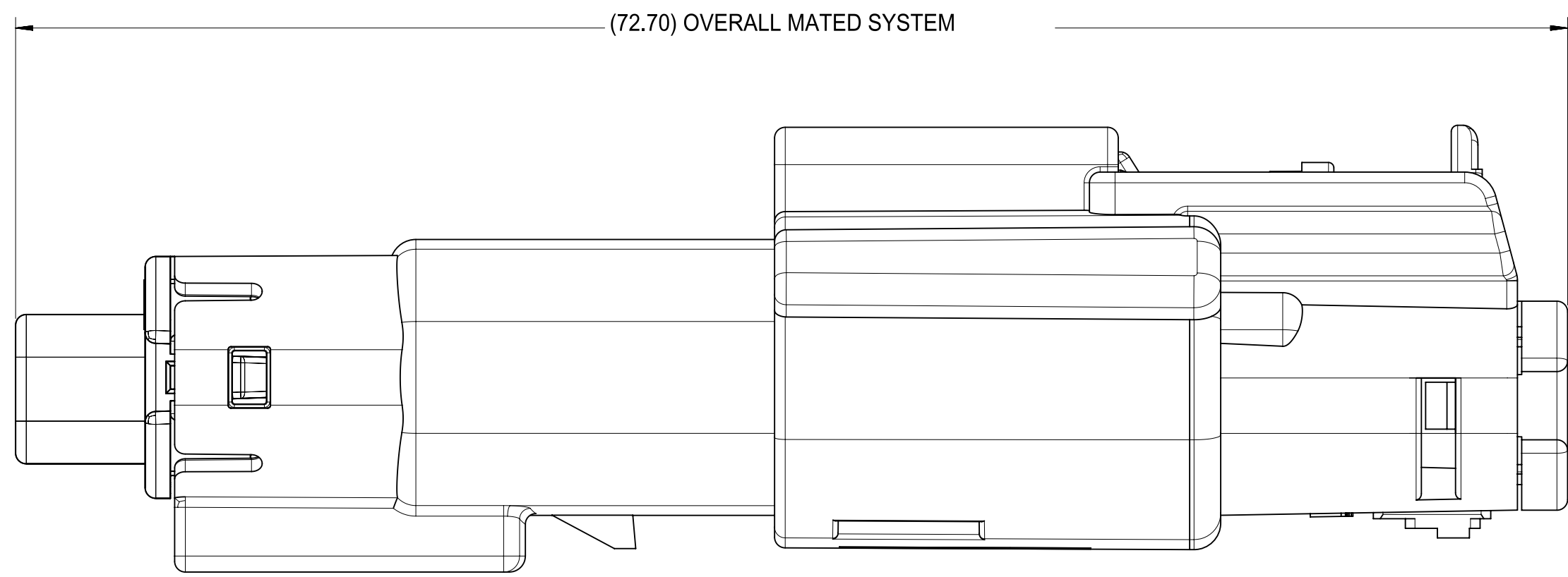

| CHARTED DIMENSIONS | |
|---------------------------------------------------|-------|
| CONFIGURATION | A |
| MX150 1X4 RECPT SEALED ASSY - STANDARD | 29.14 |
| MX150 1X4 RECPT SEALED ASSY - ERGO | 29.33 |
| MX150 1X4 RECPT SEALED ASSY - SHORTING (SHRT) BAR | 29.14 |

THIS DRAWING CONTAINS INFORMATION THAT IS PROPRIETARY TO MOLEX ELECTRONIC TECHNOLOGIES, LLC AND SHOULD NOT BE USED WITHOUT WRITTEN PERMISSION

| | | | | | | |
|------------------------------------------------------------|---------------------|-------------------------------------------|----------------------------------------|-----------------|----------------------------|--|
| DIMENSION UNITS mm | SCALE 4:1 | CURRENT REV DESC: UPDATED PARTS STATUS | molex | | | |
| GENERAL TOLERANCES (UNLESS SPECIFIED) | | EC NO: CO-000001228 | | | | |
| ANGULAR TOL ± 3° | 4 PLACES ± 0 | DRWN: MattYoung 21-Jul-2022 | DOCUMENT NUMBER SD-33481-041 | | DOC TYPE PSD | |
| 3 PLACES ± 0 | 3 PLACES ± 0 | CHK'D: Joe Fox 01-Aug-2022 | DOC PART 001 | REVISION W4 | | |
| 2 PLACES ± 0.1 | 2 PLACES ± 0.1 | APPR: Katy Boruszewski 02-Aug-2022 | INITIAL REVISION: | | | |
| 1 PLACE ± 0.3 | 1 PLACE ± 0.3 | DRWN: RFC_PLMIMP | MATERIAL NUMBER 33481 | | CUSTOMER GENERAL MARKET | |
| 0 PLACES ± 0 | 0 PLACES ± 0 | APPR: | SHEET NUMBER 4 OF 5 | | | |
| DRAFT WHERE APPLICABLE MUST REMAIN WITHIN DIMENSIONS | | THIRD ANGLE PROJECTION | DRAWING D-SIZE | SERIES 33481 | | |

| ASSEMBLY PART NUMBER | COLOR | KEYING OPTION | CAVITY TYPE & STATUS (X = PLUGGED) | | | | STATUS | COMMENTS |
|----------------------|----------|---------------|------------------------------------|---|---|---|----------|-------------------------------------|
| | | | 1 | 2 | 3 | 4 | | |
| 33481-0401 | BLACK | A | | | | | OBSOLETE | |
| 33481-0402 | LT. GRAY | B | | | | | OBSOLETE | |
| 33481-0403 | BROWN | C | | | | | OBSOLETE | NOT RECOMMENDED, SEE P/N 33481-0424 |
| 33481-0404 | GREEN | D | | | | | OBSOLETE | NOT RECOMMENDED, SEE P/N 33481-0425 |
| 33481-0405 | BLACK | C | | | | | OBSOLETE | |
| 33481-0406 | BLACK | A | | | | X | OBSOLETE | |
| 33481-0407 | LT. GRAY | B | | | | X | OBSOLETE | |
| 33481-0408 | BROWN | C | | | | X | OBSOLETE | |
| 33481-0409 | GREEN | D | | | | X | OBSOLETE | |
| 33481-0410 | CUSTOM | TBD | | | | X | OBSOLETE | |
| 33481-0411 | BLACK | A | X | | | X | OBSOLETE | |
| 33481-0412 | LT. GRAY | B | X | | | X | OBSOLETE | |
| 33481-0413 | BROWN | C | X | | | X | OBSOLETE | |
| 33481-0414 | GREEN | D | X | | | X | OBSOLETE | |
| 33481-0415 | CUSTOM | TBD | X | | | X | OBSOLETE | |
| 33481-0416 | BLACK | A | X | X | X | X | OBSOLETE | |
| 33481-0417 | LT. GRAY | B | X | X | X | X | OBSOLETE | |
| 33481-0418 | BROWN | C | X | X | X | X | OBSOLETE | NOT RECOMMENDED, SEE P/N 33481-0426 |
| 33481-0419 | GREEN | D | X | X | X | X | OBSOLETE | NOT RECOMMENDED, SEE P/N 33481-0427 |
| 33481-0420 | CUSTOM | TBD | X | X | X | X | OBSOLETE | |
| 33481-0421 | BLACK | A | | | X | | OBSOLETE | |
| 33481-0422 | BLACK | A | | | X | X | OBSOLETE | |
| 33481-0423 | LT. GRAY | B | X | X | | | OBSOLETE | |
| 33481-0424 | DK. GRAY | C | | | | | OBSOLETE | |
| 33481-0425 | ST. GRAY | D | | | | | OBSOLETE | |
| 33481-0426 | DK. GRAY | C | X | X | X | X | OBSOLETE | |
| 33481-0427 | ST. GRAY | D | X | X | X | X | OBSOLETE | |
| 33481-0428 | YELLOW | A | | | | | OBSOLETE | |
| 33481-0429 | LT. GRAY | B | | X | X | | OBSOLETE | |
| 33481-0430 | BLACK | A | X | | X | | OBSOLETE | |

| ASSEMBLY PART NUMBER | COLOR | KEYING OPTION | CAVITY TYPE & STATUS (X = PLUGGED) | | | | STATUS | COMMENTS |
|----------------------|----------|---------------|------------------------------------|---|---|---|----------|-------------------------------------|
| | | | 1 | 2 | 3 | 4 | | |
| 33481-4401 | BLACK | A | | | | | SALEABLE | |
| 33481-4402 | LT. GRAY | B | | | | | SALEABLE | |
| 33481-4403 | BROWN | C | | | | | SALEABLE | NOT RECOMMENDED, SEE P/N 33481-4424 |
| 33481-4404 | GREEN | D | | | | | SALEABLE | NOT RECOMMENDED, SEE P/N 33481-4425 |
| 33481-4405 | BLACK | C | | | | | SALEABLE | |
| 33481-4406 | BLACK | A | | | | X | SALEABLE | |
| 33481-4407 | LT. GRAY | B | | | | X | SALEABLE | |
| 33481-4408 | BROWN | C | | | | X | SALEABLE | NOT RECOMMENDED |
| 33481-4409 | GREEN | D | | | | X | SALEABLE | NOT RECOMMENDED |
| 33481-4410 | CUSTOM | TBD | | | | X | SALEABLE | |
| 33481-4411 | BLACK | A | X | | | X | SALEABLE | |
| 33481-4412 | LT. GRAY | B | X | | | X | SALEABLE | |
| 33481-4413 | BROWN | C | X | | | X | SALEABLE | NOT RECOMMENDED |
| 33481-4414 | GREEN | D | X | | | X | SALEABLE | NOT RECOMMENDED |
| 33481-4415 | CUSTOM | TBD | X | | | X | SALEABLE | |
| 33481-4416 | BLACK | A | X | X | X | X | SALEABLE | |
| 33481-4417 | LT. GRAY | B | X | X | X | X | SALEABLE | |
| 33481-4418 | BROWN | C | X | X | X | X | SALEABLE | NOT RECOMMENDED, SEE P/N 33481-4426 |
| 33481-4419 | GREEN | D | X | X | X | X | SALEABLE | NOT RECOMMENDED, SEE P/N 33481-4427 |
| 33481-4420 | CUSTOM | TBD | X | X | X | X | SALEABLE | |
| 33481-4421 | BLACK | A | | | X | | SALEABLE | |
| 33481-4422 | BLACK | A | | | X | X | SALEABLE | |
| 33481-4423 | LT. GRAY | B | X | X | | | SALEABLE | |
| 33481-4424 | DK. GRAY | C | | | | | SALEABLE | |
| 33481-4425 | ST. GRAY | D | | | | | SALEABLE | |
| 33481-4426 | DK. GRAY | C | X | X | X | X | SALEABLE | |
| 33481-4427 | ST. GRAY | D | X | X | X | X | SALEABLE | |
| 33481-4428 | YELLOW | A | | | | | SALEABLE | |
| 33481-4429 | LT. GRAY | B | | X | X | | SALEABLE | |
| 33481-4430 | BLACK | A | X | | X | | SALEABLE | |

| | | | | | | | | | |
|-----------------------------------------------------------------------------------------------------------------------------------------------|--|-------|--|------------------------------------|--|----------|--|------------------------------------------|--|
| THIS DRAWING CONTAINS INFORMATION THAT IS PROPRIETARY TO MOLEX ELECTRONIC TECHNOLOGIES, LLC AND SHOULD NOT BE USED WITHOUT WRITTEN PERMISSION | | | | | | | | | |
| DIMENSION UNITS | | SCALE | | CURRENT REV DESC: UPDATED PARTS | | | | molex | |
| mm | | 1:1 | | STATUS | | | | | |
| GENERAL TOLERANCES (UNLESS SPECIFIED) | | | | EC NO: CO-000001228 | | | | MX150 1X4 BLADE SEALED ASSEMBLY MAT SEAL | |
| ANGULAR TOL ± 3° | | | | DRWN: MattYoung 21-Jul-2022 | | | | | |
| 4 PLACES ± 0 | | | | CHK'D: Joe Fox 01-Aug-2022 | | | | PRODUCT SALES DRAWING | |
| 3 PLACES ± 0 | | | | APPR: Katy Boruszewski 02-Aug-2022 | | | | | |
| 2 PLACES ± 0.1 | | | | INITIAL REVISION: | | | | DOCUMENT NUMBER | |
| 1 PLACE ± 0.3 | | | | DRWN: RFC_PLMIMP | | | | | |
| 0 PLACES ± 0 | | | | APPR: | | | | SD-33481-041 | |
| DRAFT WHERE APPLICABLE MUST REMAIN WITHIN DIMENSIONS | | | | THIRD ANGLE PROJECTION | | DRAWING | | | |
| | | | | D-SIZE | | 33481 | | MATERIAL NUMBER | |
| | | | | GENERAL MARKET | | CUSTOMER | | SHEET NUMBER | |
| | | | | | | | | 5 OF 5 | |