

NINA-B2 series

Stand-alone dual-mode Bluetooth modules

System integration manual



Abstract

This document describes the system integration of NINA-B2 series stand-alone Bluetooth® modules. The NINA-B2 modules come with pre-flashed application software and support dual-mode Bluetooth (Bluetooth BR/EDR and Bluetooth low energy). The module has many important security features embedded, including secure boot, which ensures that only authenticated software can run on the module. This makes NINA-B2 ideal for critical IoT applications where security is important.

Document information

Title	NINA-B2 series	
Subtitle	Stand-alone dual-mode Bluetooth modules	
Document type	System integration manual	
Document number	UBX-18011096	
Revision and date	R05	1-Nov-2021
Disclosure Restriction	C1- Public	

Product status	Corresponding content status	
Functional Sample	Draft	For functional testing. Revised and supplementary data will be published later.
In Development / Prototype	Objective Specification	Target values. Revised and supplementary data will be published later.
Engineering Sample	Advance Information	Data based on early testing. Revised and supplementary data will be published later.
Initial Production	Early Production Information	Data from product verification. Revised and supplementary data may be published later.
Mass Production / End of Life	Production Information	Document contains the final product specification.

This document applies to the following products:

Product name	Product status
NINA-B221	Initial Production
NINA-B222	Initial Production

u-blox or third parties may hold intellectual property rights in the products, names, logos and designs included in this document. Copying, reproduction, modification or disclosure to third parties of this document or any part thereof is only permitted with the express written permission of u-blox.

The information contained herein is provided "as is" and u-blox assumes no liability for its use. No warranty, either express or implied, is given, including but not limited to, with respect to the accuracy, correctness, reliability and fitness for a particular purpose of the information. This document may be revised by u-blox at any time without notice. For the most recent documents, visit www.u-blox.com.

Copyright © u-blox AG.

Contents

Document information	2
Contents	3
1 System description	5
1.1 Overview.....	5
1.1.1 Block diagram	5
1.2 Product description	6
1.2.1 Radio in NINA-B2 series.....	6
1.3 CPU.....	6
1.4 Operating modes.....	6
1.4.1 Power modes	6
1.5 Supply interfaces	6
1.5.1 Module supply design (VCC).....	6
1.5.2 Digital I/O interfaces reference voltage (VCC_IO).....	7
1.5.3 VCC application circuits	7
1.6 System function interfaces	7
1.6.1 Boot strapping pins.....	7
1.7 Serial Interfaces	8
1.7.1 Universal asynchronous serial interface (UART)	8
1.7.2 Serial peripheral interface (SPI)	8
1.8 Antenna interfaces.....	9
1.8.1 Antenna pin – NINA-B221	9
1.8.2 Integrated antenna – NINA-B222.....	9
1.9 Reserved pins (RSVD)	9
1.10 GND pins	10
2 Software	11
2.1 NINA-B2 u-connectXpress software.....	11
2.2 s-center evaluation software.....	11
2.3 Updating NINA-B2	11
2.4 Updating u-connectXpress software with s-center	12
2.5 Updating u-connectXpress software from host/AT Commands.....	13
2.5.1 Setting up the serial port	14
2.5.2 Updating u-connectXpress connectivity software.....	15
3 Design-in.....	17
3.1 Overview.....	17
3.2 Supply interfaces	17
3.2.1 Module supply (VCC) design.....	17
3.2.2 Digital I/O interfaces reference voltage (VCC_IO).....	17
3.3 Antenna interface.....	18
3.3.1 RF transmission line design (NINA-B221 only)	18
3.3.2 Antenna design (NINA-B221).....	20
3.3.3 On-board antenna design (NINA-B222).....	23
3.4 Data communication interfaces	23

3.4.1 Asynchronous serial interface (UART) design.....	23
3.5 General High Speed layout guidelines	23
3.5.1 General considerations for schematic design and PCB floor-planning.....	24
3.5.2 Module placement	24
3.5.3 Layout and manufacturing	24
3.6 Module footprint and paste mask	24
3.7 Thermal guidelines	25
3.8 ESD guidelines	25
4 Handling and soldering.....	26
4.1 ESD handling precautions.....	26
4.2 Packaging, shipping, storage, and moisture preconditioning	26
4.3 Reflow soldering process.....	27
4.3.1 Cleaning	28
4.3.2 Other notes	28
5 Approvals.....	29
5.1 General requirements	29
5.2 FCC/IC End-product regulatory compliance.....	29
5.2.1 NINA-B2 series FCC ID and IC certification number	29
5.2.2 Antenna requirements	29
6 Product testing.....	31
6.1 u-blox in-line production testing	31
6.2 OEM manufacturer production test	32
6.2.1 “Go/No go” tests for integrated devices	32
Appendix.....	33
Related documents	34
Revision history	34
Contact.....	35

1 System description

1.1 Overview

The NINA-B2 series are small stand-alone dual-mode Bluetooth modules designed for ease-of-use and integration in professional applications where security is important. The modules are delivered with u-blox connectivity software, which provides support for both peripheral and central roles, Serial Port Profile, GATT client and server, beacons, u-blox Bluetooth low energy Serial Port Service – all configurable from a host using AT commands.

NINA-B222 comes with an internal antenna while NINA-B221 has a pin for use with an external antenna. The internal PIFA antenna is specifically designed for the small NINA form factor and provides an extensive range, independent of ground plane and component placement.

1.1.1 Block diagram

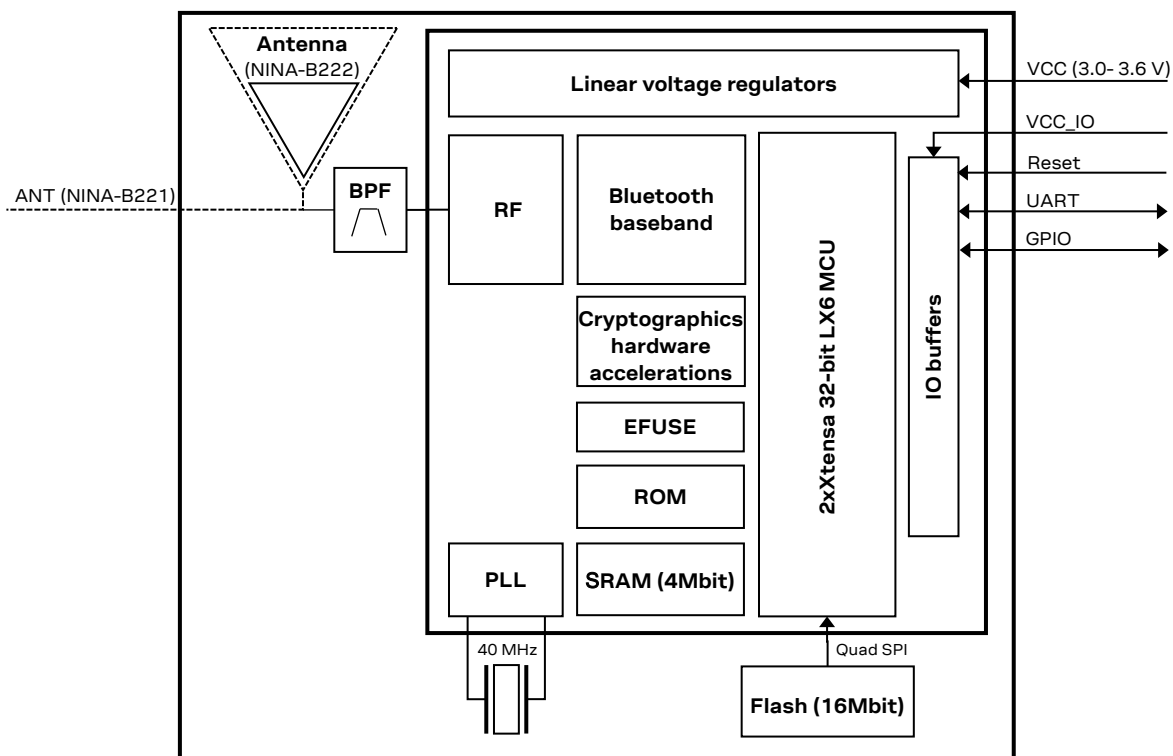

Figure 1: Block diagram of NINA-B2 series

1.2 Product description

1.2.1 Radio in NINA-B2 series

The NINA-B2 series modules support Bluetooth BR/EDR, and Bluetooth Low Energy as explained in Table 1.

Bluetooth BR/EDR	Bluetooth low energy
Bluetooth v4.2+EDR Maximum number of slaves: 7	Bluetooth 4.2 Low Energy dual-mode
Band support 2.4 GHz, 79 channels	Band support 2.4 GHz, 40 channels
Typical conducted output power - 1 Mbit/s: 6 dBm - 2/3 Mbit/s: 8 dBm	Typical conducted output power 6 dBm
Typical conducted output power - 1 Mbit/s: 6 dBm - 2/3 Mbit/s: 8 dBm	Typical conducted output power 6 dBm
Typical radiated output power - 1 Mbit: 9 dBm EIRP* - 2/3 Mbit/s: 11 dBm EIRP*	Typical radiated output power 9 dBm EIRP*
Conducted sensitivity -88 dBm	Conducted sensitivity -88 dBm
Data rates: 1 / 2 / 3 Mbit/s	Data rates: 1 Mbit/s

* RF power including maximum antenna gain (3 dBi).

Table 1: NINA-B2 series - Bluetooth characteristics

1.3 CPU

The NINA-B2 series has a dual-core system with two Harvard Architecture Xtensa LX6 CPUs with maximum 240 MHz internal clock frequency. The internal memory of NINA-B2 includes the following:

- 448 Kbyte ROM for booting and core functions
- 520 Kbyte SRAM for data and instruction
- 16 Mbit FLASH for code storage including hardware encryption to protect programs and data
- 1 kbit EFUSE (non-erasable memory) for MAC addresses, module configuration, Flash-Encryption, and Chip-ID

1.4 Operating modes

1.4.1 Power modes

The NINA-B2 series modules are power efficient devices capable of operating in different power saving modes and configurations. Different sections of the module can be powered off when not needed and complex wake up events can be generated from different external and internal inputs.

1.5 Supply interfaces

1.5.1 Module supply design (VCC)

The NINA-B2 series modules use an integrated Linear Voltage converter to transform the supply voltage presented at the **VCC** pin into a stable system voltage.

1.5.2 Digital I/O interfaces reference voltage (VCC_IO)

All modules in the NINA-B2 series provide an additional voltage supply input for setting the I/O voltage level.

The separate **VCC_IO** pin enables integration of the module in many applications with different voltage levels (for example, 1.8 V or 3.3 V) without any level converters. The NINA-B2 modules support only 3.3 V as IO voltage level currently.

1.5.3 VCC application circuits

The power for the NINA-B2 series modules is provided through the VCC pins, which can be one of the following:

- Switching Mode Power Supply (SMPS)
- Low Drop Out (LDO) regulator

The SMPS is the ideal choice when the available primary supply source has higher value than the operating supply voltage of the NINA-B2 series modules. The use of SMPS provides the best power efficiency for the overall application and minimizes current drawn from the main supply source.

 While selecting SMPS, ensure that AC voltage ripple at switching frequency is kept as low as possible. Layout shall be implemented to minimize impact of high frequency ringing.

The use of an LDO linear regulator is convenient for a primary supply with a relatively low voltage where the typical 85-90% efficiency of the switching regulator leads to minimal current saving. Linear regulators are not recommended for high voltage step-down as they will dissipate a considerable amount of energy.

DC/DC efficiency should be evaluated as a tradeoff between active and idle duty cycle of the specific application. Although some DC/DC can achieve high efficiency at extremely light loads, a typical DC/DC efficiency quickly degrades as idle current drops below a few mA greatly reducing the battery life.

It is considered as a best practice to have decoupling capacitors on the supply rails close to the NINA-B2 series module, although depending on the design of the power routing on the host system, capacitance might not be needed.

See the NINA-B2 series data sheet [2] for electrical specifications.

1.6 System function interfaces

1.6.1 Boot strapping pins

There are several boot configuration pins available on the module that must have the correct settings during boot (see Table 2). The boot strap pins are configured to the default state internally on the module and must NOT be configured externally.

During boot, pin 32 controls if additional system information should be transmitted on the UART interface during startup. After the system has booted, it is reconfigured to **SPI_CS**, the SPI chip select signal.

During boot, pin 36 controls the voltage level of the internal flash during startup. After the system has booted, it is reconfigured to the SPI slave data output signal, **SPI_MISO**. It must NOT be pulled down by an external MCU or circuitry.

Pin	State during boot	Default	Behavior	Description
27	0		ESP boot mode (factory boot)	ESP Factory boot Mode/RMII clock line.
	1	Pull-up*	Normal Boot from internal Flash	
32	0		Silent	Printout on UART0 TXD during boot
	1	Pull-up*	UART0 TXD Toggling	
36	0		VDD_SDIO=3.3V (Not allowed)	Internal flash voltage
	1	10 kΩ pull-up	VDD_SDIO=1.8V (VDD_SDIO should always be at 1.8 V)	

*About 30 kΩ

Table 2: NINA-B2 series boot strapping pins

1.7 Serial Interfaces

1.7.1 Universal asynchronous serial interface (UART)

The NINA-B2 series module provides a Universal Asynchronous Serial Interface (UART) for data communication. The following UART signals are available:

- Data lines (**RXD** as input, **TXD** as output)
- Hardware flow control lines (**CTS** as input, **RTS** as output)
- **DSR** and **DTS** are used to set and indicate the system modes

The UART can be used as 4-wire UART with hardware flow control and 2-wire UART with only **TXD** and **RXD**. In 2-wire mode, **CTS** must be connected to the GND on the NINA-B2 module.

The UART interface is also be used for firmware upgrade. See also [Software](#).

The u-connectXpress software adds the **DSR** and **DTR** pins to the UART interface. These pins are not used as they were originally intended but are used instead to control the state of NINA modules.

Depending on the configuration, **DSR** can be used to:

- Enter command mode
- Disconnect and/or toggle connectable status
- Enable/disable the rest of the UART interface
- Enter/wake up from the Stop mode

The functionality of the **DSR** and **DTR** pins are configured by AT commands. See also the u-connectXpress AT commands manual [1] for more information.

See NINA-B2 series data sheet [2] for characteristic information about the UART interface.

Interface	Default configuration
UART interface	115200 baud, 8 data bits, no parity, 1 stop bit, hardware flow control

Table 3: Default settings for the UART port while using the u-blox connectivity software

It is advisable to make the UART available either as test points or connected to a header for firmware upgrade.

The IO level of the UART will follow the **VCC_IO**.

1.7.2 Serial peripheral interface (SPI)

 On NINA-B2, SPI is supported from software version 3.0.0 onwards.

In addition to UART support, NINA-B2 modules also include a Serial Peripheral Interface (SPI) for data communication. The module acts as an SPI slave.

The following SPI signals are available:

- Chip select as input (**SPI_CS**)
- Data lines (**SPI_MOSI** as input, and **SPI_MISO** as output)
- Clock (**SPI_SCLK** as input)
- Optional hardware flow control lines (**SPI_NORX** and **SPI_DRDY** as output)

For details on SPI operation, see the Communicating with a u-blox module over SPI bus, application note [7].

1.8 Antenna interfaces

The antenna interface is different for each module variant in the NINA-B2 series.

1.8.1 Antenna pin – NINA-B221

NINA-B221 modules are equipped with an RF pin. The RF pin has a nominal characteristic impedance of 50 Ω and must be connected to the antenna through a 50 Ω transmission line to allow reception of radio frequency (RF) signals in the 2.4 GHz frequency band.

Choose an antenna with optimal radiating characteristics for the best electrical performance and overall module functionality. An internal antenna, integrated on the application board or an external antenna that is connected to the application board through a proper 50 Ω connector can be used.

While using an external antenna, the PCB-to-RF-cable transition must be implemented using either a suitable 50 Ω connector, or an RF-signal solder pad (including GND) that is optimized for 50 Ω characteristic impedance.

1.8.1.1 Antenna matching

The antenna return loss should be as good as possible across the entire band when the system is operational to provide optimal performance. The enclosure, shields, other components, and surrounding environment will impact the return loss seen at the antenna port. Matching components are often required to retune the antenna to bring the return loss within an acceptable range.

It is difficult to predict the actual matching values for the antenna in the final form factor. Therefore, it is a good practice to have a placeholder in the circuit that includes a "pi" network, with two shunt components and a series component in the middle. This provides maximum flexibility while the tuning is matched to the antenna feed.

1.8.1.2 Approved antenna designs

NINA-B2 modules come with a pre-certified design that can be used to save costs and time during the certification process. To take advantage of this service, you have to implement the antenna layout according to the u-blox reference designs. The reference design is available on request from u-blox.

The designer integrating a u-blox reference design into an end-product is solely responsible for the unintentional emission levels produced by the end product.

The module may be integrated with other antennas. In this case, the OEM installer must certify his design with respective regulatory agencies.

1.8.2 Integrated antenna – NINA-B222

NINA-B222 modules are equipped with an integrated antenna on the module for simpler integration.

1.9 Reserved pins (RSVD)

RSVD pins should be left unconnected.

1.10 GND pins

Good connection of the module GND pins, with solid ground layer of the host application board, is required for correct RF performance. This significantly reduces the EMC issues and provides a thermal heat sink for the module.

2 Software

2.1 NINA-B2 u-connectXpress software

NINA-B2 is delivered with the u-blox connectivity software.

Using industry-standard AT commands, this is the software that manages the combination of Bluetooth and Bluetooth Low Energy connectivity supported in NINA-B2 standalone modules.

The u-blox connectivity software enables the use of Bluetooth, controlled by the AT commands over the UART interface. For more information on the features and capabilities of the u-blox connectivity software and how to use it, see also the u-connectXpress AT commands manual [1] and u-connectXpress user guide [5].

Figure 2 shows the structure of the embedded u-connectXpress software delivered in NINA-B2 standalone modules.

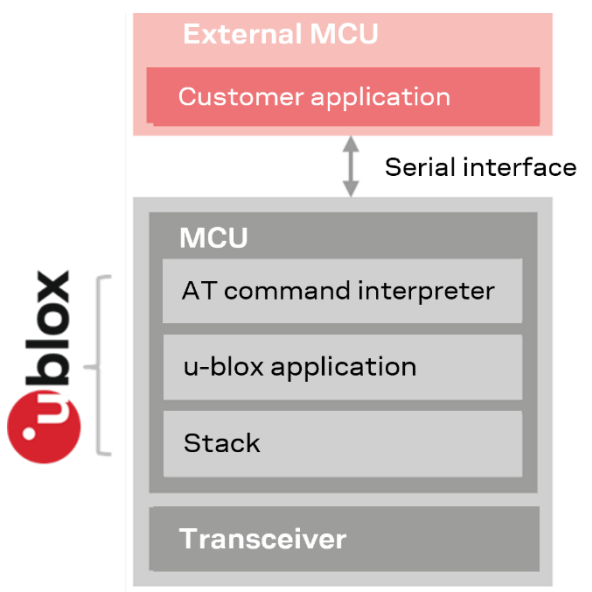

Figure 2: NINA-B2 u-connectXpress software structure

2.2 s-center evaluation software

u-blox s-center client software provides a convenient tool with which to configure u-blox standalone modules. It runs on PCs running Windows XP onwards (x86 and x64) with Net Framework 4.5 or later and is available for download from www.u-blox.com. For further information about how to use this tool, see also the s-center user guide [6].

2.3 Updating NINA-B2

To ensure that the module only boots with the original u-blox software, the secure bootloader initiates a signature verification on the flashed software binary before it is booted.

NINA-B2 u-connectXpress software can be re-flashed over the UART interface using AT commands or the s-center client software available from the u-blox website. The flash procedure uses the XMODEM protocol.

The following pins should be made available as either headers or test points to flash the module:

- UART (RXD, TXD, CTS, RTS)
- Pin 27

- **RESET_N**
- **SWITCH_1** and **SWITCH_2** (optional)

To enable re-programming of the module, UART signals connected to host must not interfere with the flashing procedure. UART pins must be put in tri-state by host or have the possibility to disconnect completely. Another option is to let host software handle the update procedure (e.g., implement the XMODEM protocol or a UART pass-through function).

2.4 Updating u-connectXpress software with s-center

The u-connectXpress software, flashed into NINA-B2 module prior to delivery, is used to validate the hardware, bootloader, and binary image. The u-connectXpress software runs only on validated hardware.

Updates of the u-connectXpress software is available for download from www.u-blox.com. Distributed in a single ZIP container, the software includes one binary file and one JSON file that contains the software label, software description, file name, version, flash address, image size, image id, file permissions, and signature file for the Connectivity Software application:

- **Java Script Object Notation:**
NINA-B22X-CF-<version>.json. For example: NINA-B22X-CF-1.0.json
- **Connectivity Software:**
NINA-B22X-SW-x.y.z-<build>.bin. For example: NINA-B22X-SW-4.0.0-003.bin
- **Signature File:** NINA-B22X-SI-4.0.0-003.bin

 To update NINA-B2 u-connectXpress requires s-center software version 4.7 or later. See also the s-center user guide [5].

Procedure:

1. Connect the supplied serial cable on EVK-NINA-B2 to the USB port your computer. For further information about setting up EVK-NINA-B2, see also EVK-NINA-B2 user guide [5].
2. Download and the latest version of the s-center and u-connectXpress software from u-blox [Product Resources](#). See also the EVK-NINA-B2 user guide [5] and s-center user guide [5].
3. Start s-center and choose "USB Serial Port (COMx)" in the drop-down "COM Port" menu. All other dialog settings are set to default.
4. Select **Open Port**. A series of AT commands and response are shown in the "Console Window".
5. Select **Tools > Software Update**.

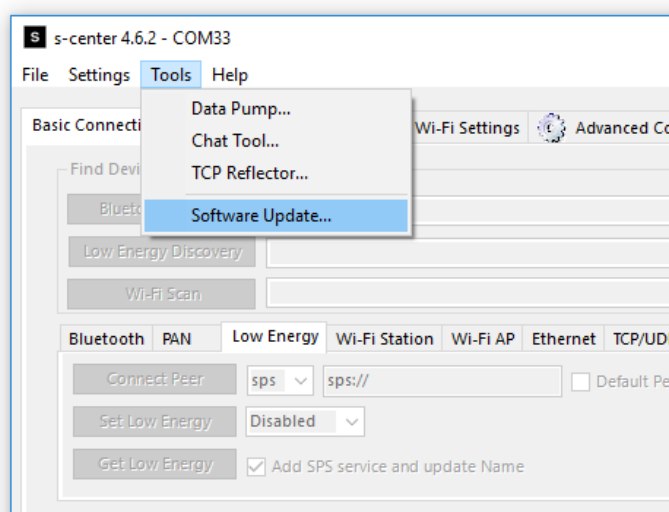

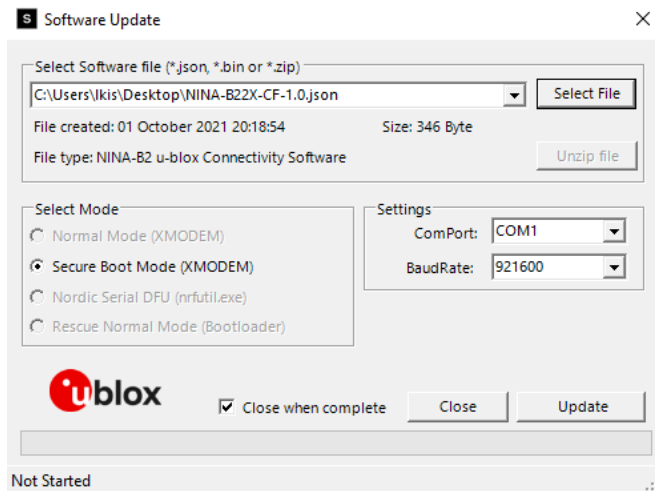

Secure boot functionality is supported in u-connect v4.7 and above.

7. Select **Update**. The module then reboots using the secure bootloader and application starts automatically.

2.5 Updating u-connectXpress software from host/AT Commands

You can send AT commands to NINA-B2 to execute certain tasks over the serial interface, using open-source terminal emulator software that supports XMODEM, like TeraTerm or ExtraPuTTY. Alternatively, you can send all AT commands described in this section using the s-center software in AT mode. The examples given in this procedure have been created and tested on EVK-NINA-B2 using TeraTerm. See also the u-connectXpress AT command manual [5] and Bootloader protocol specification [5].

The bootloader must be running when the software is “sent” to the module. You start the bootloader using either:

- AT commands
- Pressing the **SWITCH_1** and **SWITCH_2** simultaneously during a module reset (initiated by setting **RESET_N** low).

In contrast to the s-center configuration, UART hardware flow is not used for updating software using AT commands. The file download uses standard XMODEM-CRC16 protocol and 128 bytes packets.

Prerequisites

As a prerequisite to updating software using AT commands, you must open the JSON file included in the download container and make note of the defined values to be parsed with the update command as shown in Figure 3. You also need to copy the signature given in the related txt files, as shown in Figure 4. This information is needed during the install. The defined values to include in the command, together with the signature file (NINA-B22X-SI-x.x.x-xxx.txt), are shown in Table 4.

```
[
  {
    "Label": "ConnectivitySoftware",
    "Description": "NINA-B22X u-blox connectivity software",
    "File": "NINA-B22X-SW-4.0.0-003.bin",
    "Version": "NINA-B22X-SW-4.0.0-003",
    "Address": "0x20000",
    "Size": "0xA1740",
    "Id": "0x0",
    "Permissions": "rwx",
    "SignatureFile": "NINA-B22X-SI-4.0.0-003.txt"
  }
]
```

Figure 3: Defined values for Connectivity Software as shown in the JSON file

```
Oduj9zhDz1QX+r2wnRmxy7m7d8SW5mkou9Xwph2cuifeOu7Rz8tU1E31cSyX4BSRE6uEnHFADPKo88yZT+7rAYo3W37b
5Q5pVE/zazwPq80tX4oJoROtmDItU9pj64Ygt84MqVsv+Aq576oDw/wjplSUnc8apS5UjWacutQYSJNYtc5DV7kCjnM
ul175GxzWgiwOKiFYC8cutklHqYKbFvd/oHhwyZb1lQNI5Z1J6FXcZg0lw+NdiUP85gR5nSIGngjew9iKHozLX90Zpj/2
kQtXRgbsGcGtWzJXVMtY+K+B9qAMBsmBx3NofACcB6vA3Gi3dPv/L0ggiTf3fG6CQ==
```

Figure 4: Typical Connectivity Software signature file

Command syntax

You use the software update command `AT+UFWUPD` with following syntax to update the u-connectXpress software.

```
AT+UFWUPD=<mode>,<baud_rate>[,<id>,<size>,<signature>,<name>,<flags>]
```

The defined values for each parameter are shown in Table 4.

Parameter	Type	Description
<mode>	Enumerator	Download mode: 0: Update mode for the Connectivity Software through the serial port 1: Bootloader mode for update of the SoftDevice through the serial port.
<baud rate>	Enumerator	Baud rate in bits per second: 115200 (default), 230400, 460800, or 921600
<id>	Integer	ID number of the software image.
<size>	Integer	Size of the firmware image. Enter the size integer for the respective software as defined in the <code>NINA-B22X-SI-x.x.x-xxx.txt</code> file. Shown in hex format in the JSON file but must entered as bytes in decimal notation in the command.
<signature>	String	RSA signature of the firmware image as base64-encoded string. Enter the 344-character text string defined in the <code>NINA-B22X-SI-x.x.x-xxx.txt</code> file.
<name>	String	The name of the firmware. Maximum string length is 22.
<flags>	String	Permissions for using the firmware image. Permission flags are marked in UNIX style: "rwx" is the default flag for the u-connectXpress software. "rw" is the default flag for other binary images.

Table 4: Defined values for update parameters

2.5.1 Setting up the serial port

You can send AT text commands to NINA-B2 to execute tasks using open-source terminal emulator software that supports XMODEM like TeraTerm or ExtraPuTTY. Alternatively, you can send all AT commands described in this section using the s-center software in AT mode.

Procedure:

The examples in this procedure have been created and tested on EVK-NINA-B2 using TeraTerm.

1. Connect the supplied serial cable from the J8 connector on EVK-NINA-B2 to the USB port your computer. For more information about setting up EVK-NINA-B2, see also EVK-NINA-B2 user guide [4].
2. Download and unzip the latest u-connectXpress software from u-blox [Product Resources](#).
3. Discover the COM port number for the USB Serial Port on your computer (MS Windows: **Start>Device Manager>Ports**). See also “Setting up the evaluation board” in the EVK-NINA-B2 user guide [5].

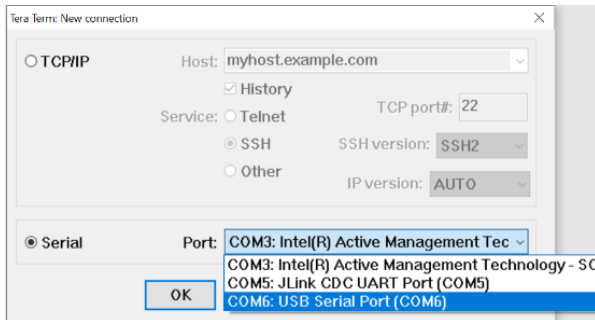

2.5.2 Updating u-connectXpress connectivity software

Procedure:

The examples in this procedure have been created and tested on EVK-NINA-B2 using TeraTerm.

1. Setup the serial port connection as described in [Setting up the serial port](#).
2. Enter Software version identification `AT+GMR` command to find out the current version of your u-connectXpress software.

```

AT+GMR
"2.0.0-025"
OK
    
```

- Prepare the module to accept a binary file for download and start the bootloader at the appropriate baud rate. Enter the Update software `AT+UFWUPD` command together with the Connectivity Software values defined in the `NINA-B22X-CF-<version>.json` file and the signature in the `NINA-B22X-SI-x.x.x-xxx.txt` file. The bootloader must be running when the software is “sent” to the module in the next step. Note particularly that `<mode>=0`, `<name>=ConnectivitySoftware`, and `<flags>=rwx`.

```
AT+UFWUPD=0,115200,0,651840,jz1RIkg37ir/pVpDKVrPot2ZdsaNvUtSYP2pDAUVJc7iQI9yzIo8VF
v8C1o1P/9I4UJ4WmgC5oRay4AC0V8jRJSFFX/wop6x/sBJGOeDEu7yC/s0+Oj7CLs4TzNbiRqK0zLwKRiH
ohgVyzWqhwKFpmcxcDXphjkCTIvpffY8TwDLzkowuuD59R+sQCueJtBHBg9KDB3TOs8bsXLaVtT2x1rLfm
g8/pb+BPQEK9NcNB4hbp693ATivYE3cmxzWykIjEje819SIRGhHFt0wAsqh7WFGSJYNgDi5cLdOYZ+r1+j
7+14RqrM1/A/QYyWS9z0Q15QcJ3G1AJ1XYa5v/ISjA==,nina-b2-debug,rwx
```

NINA-B2 returns a series of “c” characters for as long as the bootloader is running. The XMODEM download is ready to begin from the host.

```
cccccccccccccccccccccccccccccccc
```

- While the bootloader is running, send the u-connectXpress `NINA-B22X-SW-4.0.0-0.003.bin` file to NINA-B2.

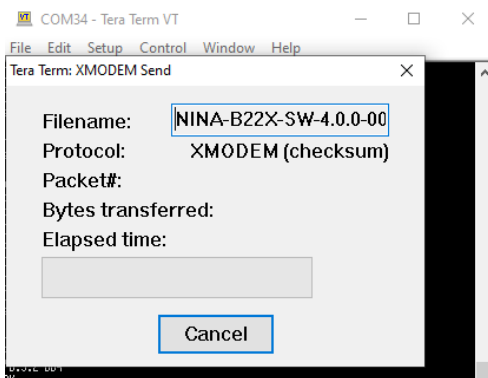

- Once the binary file has been sent, NINA-B2 displays the greeting text `+STARTUP`. Enter the Software version identification `AT+GMR` command again to make sure that the latest software version is now installed.

```
+STARTUP
AT+GMR
"4.0.0-003"
OK
```

For more information about the parameters, see the Software update `+UFWUPD` command in u-connectXpress AT Commands Manual [1], u-connectXpress bootloader protocol specification [8], and u-connectXpress user guide [5].

3 Design-in

3.1 Overview

For an optimal integration of NINA-B2 series modules in the final application board, it is recommended to follow the design guidelines stated in this chapter. Every application circuit must be properly designed to guarantee the correct functionality of the related interface; however, several points require high attention during the design of the application device.

The following list provides important points sorted by rank of importance in the application design, starting from the highest relevance:

1. Module antenna connection: **Ant** pad
Antenna circuit affects the RF compliance of the device integrating NINA-B221 modules with applicable certification schemes. Follow the schematic and layout design recommendations described in [Antenna interface](#).
2. Module supply: **VCC**, **VCC_IO**, and **GND** pins
The supply circuit affects the performance of the device integrating NINA-B2 series module. Follow the schematic and layout design recommendations described in [Supply interfaces](#).
3. High speed interfaces: **UART** pins
High speed interfaces can be a source of radiated noise and can affect compliance with regulatory standards for radiated emissions. Follow the schematic and layout design recommendations described in [Asynchronous serial interface \(UART\) design](#).
4. System functions: **RESET_N**, **GPIO** and other **System input and output pins**
Accurate design is required to guarantee that the voltage level is well defined during module boot. Other pins: Accurate design is required to guarantee proper functionality.

3.2 Supply interfaces

3.2.1 Module supply (VCC) design

Good connection of the module's VCC pin with DC supply source is required for correct RF performance. The guidelines are summarized below:

- The VCC connection must be as wide and short as possible.
- The VCC connection must be routed through a PCB area separated from sensitive analog signals and sensitive functional units. It is a good practice to interpose at least one layer of the PCB ground between VCC track and other signal routing.

There is no strict requirement of adding bypass capacitance to the supply net close to the module. But depending on the layout of the supply net and other consumers on the same net, bypass capacitors might still be beneficial. Though the GND pins are internally connected, connect all the available pins to solid ground on the application board, as a good (low impedance) connection to an external ground can minimize power loss and improve RF and thermal performance.

3.2.2 Digital I/O interfaces reference voltage (VCC_IO)

Good connection of the module's VCC_IO pin with DC supply source is required for correct performance. The guidelines are summarized below:

- The VCC_IO connection must be as wide and short as possible.
- The VCC_IO connection must be routed through a PCB area separated from sensitive analog signals and sensitive functional units. It is a good practice to interpose at least one layer of PCB ground between VCC_IO track and other signal routing.

There is no strict requirement of adding bypass capacitance to the supply net close to the module. But depending on the layout of the supply net and other consumers on the same net, bypass capacitors might still be beneficial. Though the GND pins are internally connected, connect all the available pins to solid ground on the application board, as a good (low impedance) connection to an external ground can minimize power loss and improve RF and thermal performance.

3.3 Antenna interface

As the unit cannot be mounted arbitrarily, the placement should be chosen with consideration so that it does not interfere with radio communication. The NINA-B222 modules with an internal surface mounted antenna cannot be mounted in a metal enclosure. No metal casing or plastics using metal flakes should be used. Avoid metallic based paint or lacquer as well. The NINA-B222 modules offer more freedom as an external antenna can be mounted further away from the module.

- According to the FCC regulations, the transmission line from the module's antenna pin to the antenna or antenna connector on the host PCB is considered part of the approved antenna design. Therefore, module integrators must either follow exactly one of the antenna reference design used in the module's FCC type approval or certify their own designs.

3.3.1 RF transmission line design (NINA-B221 only)

RF transmission lines, such as the ones from the **ANT** pad up to the related antenna connector or up to the related internal antenna pad, must be designed so that the characteristic impedance is as close as possible to 50Ω . Figure 5 shows the design options and the main parameters to be taken into account when implementing a transmission line on a PCB:

- The microstrip (a track coupled to a single ground plane, separated by dielectric material)
- The coplanar microstrip (a track coupled to the ground plane and side conductors, separated by dielectric material)
- The stripline (a track sandwiched between two parallel ground planes, separated by dielectric material).

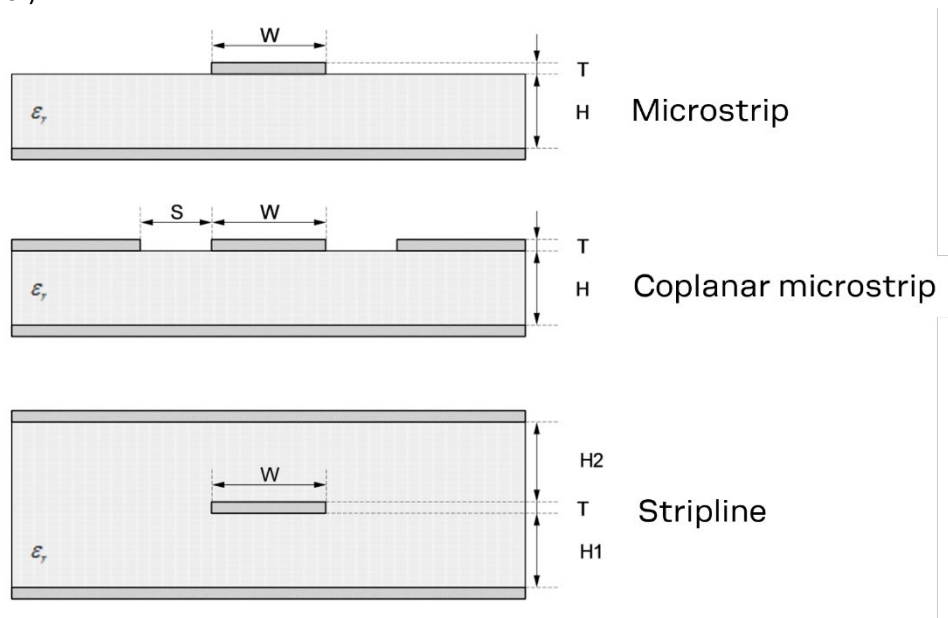

Figure 5: Transmission line trace design

To properly design a 50 Ω transmission line, the following remarks should be taken into account:

- The designer should provide enough clearance from surrounding traces and ground in the same layer; in general, a trace to ground clearance of at least two times the trace width should be considered, and the transmission line should be ‘guarded’ by a ground plane area on each side.
- The characteristic impedance can be calculated as first iteration using tools provided by the layout software. It is advisable to ask the PCB manufacturer to provide the final values that are usually calculated using dedicated software and available stack-ups from production. It could also be possible to request an impedance coupon on panel’s side to measure the real impedance of the traces.
- FR-4 dielectric material, although its high losses at high frequencies can be considered in RF designs provided that:
 - RF trace length must be minimized to reduce dielectric losses.
 - If traces longer than few centimeters are needed, it is recommended to use a coaxial connector and cable to reduce losses
 - Stack-up should allow for thick 50 Ω traces and at least 200 μm trace width is recommended to assure good impedance control over the PCB manufacturing process.
 - FR-4 material exhibits poor thickness stability and thus less control of impedance over the trace length. Contact the PCB manufacturer for specific tolerance of controlled impedance traces.
- The transmission lines width and spacing to the GND must be uniform and routed as smoothly as possible: route RF lines in 45 °C angle or in arcs.
- Add GND stitching vias around transmission lines.
- Ensure solid metal connection of the adjacent metal layer on the PCB stack-up to main ground layer, providing enough vias on the adjacent metal layer.
- Route RF transmission lines far from any noise source (as switching supplies and digital lines) and from any sensitive circuit to avoid crosstalk between RF traces and Hi-impedance or analog signals.
- Avoid stubs on the transmission lines, any component on the transmission line should be placed with the connected pad over the trace. Also avoid any unnecessary component on RF traces.

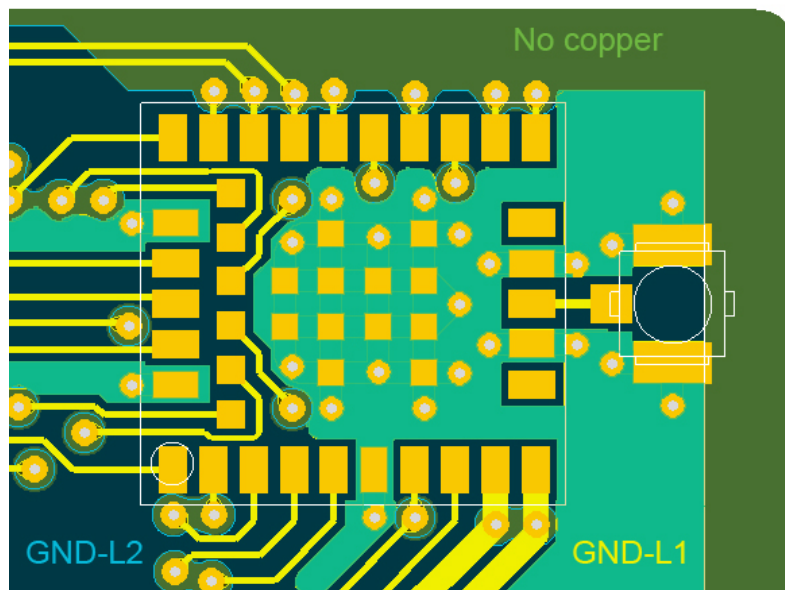

Figure 6: Example of RF trace and ground design from NINA-B2 Evaluation Kit (EVK)

3.3.2 Antenna design (NINA-B221)

Designers must take care of the antennas from all perspective at the beginning of the design phase when the physical dimensions of the application board are under analysis/decision, as the RF compliance of the device integrating NINA-B2 module with all the applicable required certification schemes heavily depends on the radiating performance of the antennas. The designer is encouraged to consider one of the u-blox suggested antenna part numbers and follow the layout requirements.

- External antennas such as linear monopole:
 - External antennas basically do not imply physical restriction to the design of the PCB where the module is mounted.
 - The radiation performance mainly depends on the antennas. It is required to select antennas with optimal radiating performance in the operating bands.
 - RF cables should be carefully selected with minimum insertion losses. Additional insertion loss will be introduced by low quality or long cable. Large insertion loss reduces radiation performance.
 - A high quality 50 Ω coaxial connector provides proper PCB-to-RF-cable transition.
- Integrated antennas such as patch-like antennas:

- Internal integrated antennas imply physical restriction to the PCB design:

Integrated antenna excites RF currents on its counterpoise, typically the PCB ground plane of the device that becomes part of the antenna; its dimension defines the minimum frequency that can be radiated. Therefore, the ground plane can be reduced down to a minimum size that should be similar to the quarter of the wavelength of the minimum frequency that has to be radiated, given that the orientation of the ground plane related to the antenna element must be considered.

The RF isolation between antennas in the system has to be as high as possible and the correlation between the 3D radiation patterns of the two antennas has to be as low as possible. In general, an RF separation of at least a quarter wavelength between the two antennas is required to achieve a maximum isolation and low pattern correlation; increased separation should be considered, if possible, to maximize the performance and fulfil the requirements in Table 5.

As a numerical example, the physical restriction to the PCB design can be considered as shown below:

Frequency = 2.4 GHz → Wavelength = 12.5 cm → Quarter wavelength = 3.125 cm¹

- Radiation performance depends on the whole product and antenna system design, including product mechanical design and usage. Antennas should be selected with optimal radiating performance in the operating bands according to the mechanical specifications of the PCB and the whole product.

¹ Wavelength referred to a signal propagating over the air.

Table 5 summarizes the requirements for the antenna RF interface:

Item	Requirements	Remarks
Impedance	50 Ω nominal characteristic impedance	The impedance of the antenna RF connection must match the 50 Ω impedance of the ANT pin.
Frequency range	2400 - 2500 MHz	Bluetooth.
Return loss	$S_{11} < -10$ dB (VSWR < 2:1) recommended $S_{11} < -6$ dB (VSWR < 3:1) acceptable	The Return loss or the S_{11} , as the VSWR, refers to the amount of reflected power, measuring how well the primary antenna RF connection matches the 50 Ω characteristic impedance of the ANT pin. The impedance of the antenna termination must match as much as possible the 50 Ω nominal impedance of the ANT pin over the operating frequency range thus, maximizing the amount of the power transferred to the antenna.
Efficiency	> -1.5 dB (> 70%) recommended > -3.0 dB (> 50%) acceptable	The radiation efficiency is the ratio of the radiated power to the power delivered to the antenna input; the efficiency is a measure of how well an antenna receives or transmits.
Maximum gain	Refer to the data sheet [2]	The maximum antenna gain must not exceed the value specified in type approval documentation to comply with the radiation exposure limits specified by regulatory agencies.

Table 5: Summary of antenna interface (ANT) requirements for NINA-B221

Observe the following recommendations when selecting external or internal antennas:

- Select antennas that provide optimal return loss (or VSWR) figure over all the operating frequencies.
- Select antennas that provide optimal efficiency figure over all the operating frequencies.
- Select antennas that provide appropriate gain figure (that is, combined antenna directivity and efficiency figure) so that the electromagnetic field radiation intensity does not exceed the regulatory limits specified in some countries (for example, by FCC in the United States).

3.3.2.1 RF connector design

If an external antenna is required, the designer should consider using a proper RF connector. It is the responsibility of the designer to verify the compatibility between plugs and receptacles used in the design.

Table 6 suggests some RF connector plugs that can be used by the designers to connect RF coaxial cables based on the declaration of the respective manufacturers. The Hirose U.FL-R-SMT RF receptacles (or similar parts) require a suitable mated RF plug from the same connector series. Due to wide usage of this connector, several manufacturers offer compatible equivalents.

Manufacturer	Series	Remarks
Hirose	U.FL [®] Ultra Small Surface Mount Coaxial Connector	Recommended
I-PEX	MHF [®] Micro Coaxial Connector	
Tyco	UMCC [®] Ultra-Miniature Coax Connector	
Amphenol RF	AMC [®] Amphenol Micro Coaxial	
Lighthouse Technologies, Inc.	IPX ultra micro-miniature RF connector	

Table 6: U.FL compatible plug connector

Typically, the RF plug is available as a cable assembly. Different types of cable assembly are available; the user should select the cable assembly best suited to the application. The key characteristics are:

- RF plug type: select U.FL or equivalent
- Nominal impedance: 50 Ω
- Cable thickness: Typically from 0.8 mm to 1.37 mm. Select thicker cables to minimize insertion loss.
- Cable length: Standard length is typically 100 mm or 200 mm; custom lengths may be available on request. Select shorter cables to minimize insertion loss.

- RF connector on the other side of the cable: For example, another U.FL. (for board-to-board connection) or SMA (for panel mounting)

Consider that SMT connectors are typically rated for a limited number of insertion cycles. Additionally, the RF coaxial cable may be relatively fragile compared to other types of cables. To increase application ruggedness, connect U.FL connector to a more robust connector such as SMA fixed on panel.

- A de-facto standard for SMA connectors implies the usage of reverse polarity connectors (RP-SMA) on Wi-Fi and Bluetooth® end products to increase the difficulty for the end user to replace the antenna with higher gain versions and exceed regulatory limits.

The following recommendations apply for proper layout of the connector:

- Strictly follow the connector manufacturer's recommended layout:
 - SMA Pin-Through-Hole connectors require GND keep-out (that is, clearance, a void area) on all the layers around the central pin up to annular pads of the four GND posts.
 - U.FL. surface mounted connectors require no conductive traces (that is, clearance, a void area) in the area below the connector between the GND land pads.
- If the connector's RF pad size is wider than the micro strip, remove the GND layer beneath the RF connector to minimize the stray capacitance thus keeping the RF line 50 Ω. For example, the active pad of the U.FL. connector must have a GND keep-out (that is, clearance, a void area) at least on the first inner layer to reduce parasitic capacitance to ground.

3.3.2.2 Integrated antenna design

If integrated antennas are used, the transmission line is terminated by the integrated antennas themselves. Follow the guidelines mentioned below:

- The antenna design process should begin at the start of the whole product design process. Self-made PCBs and antenna assembly are useful in estimating overall efficiency and radiation path of the intended design.
- Use antennas designed by an antenna manufacturer providing the best possible return loss (or VSWR).
- Provide a ground plane large enough according to the related integrated antenna requirements. The ground plane of the application PCB may be reduced down to a minimum size that must be similar to one quarter of wavelength of the minimum frequency that has to be radiated; however overall antenna efficiency may benefit from larger ground planes.
- Proper placement of the antenna and its surroundings is also critical for antenna performance. Avoid placing the antenna close to conductive or RF-absorbing parts such as metal objects, ferrite sheets and so on as they may absorb part of the radiated power or shift the resonant frequency of the antenna or affect the antenna radiation pattern.
- It is highly recommended to strictly follow the detailed and specific guidelines provided by the antenna manufacturer regarding correct installation and deployment of the antenna system, including PCB layout and matching circuitry.
- Further to the custom PCB and product restrictions, antennas may require tuning/matching to comply with all the applicable required certification schemes. It is recommended to consult the antenna manufacturer for the design-in guidelines and plan the validation activities on the final prototypes like tuning/matching and performance measures. See also Table 5.
- RF section may be affected by noise sources like hi-speed digital buses. Avoid placing the antenna close to buses such as DDR or consider taking specific countermeasures like metal shields or ferrite sheets to reduce the interference.

- ⚠ Take care of interaction between co-located RF systems like LTE sidebands on 2.4 GHz band. Transmitted power may interact or disturb the performance of NINA-B2 modules.

3.3.3 On-board antenna design (NINA-B222)

Keep a minimum clearance of 5 mm between the antenna and the casing. Keep a minimum of 10 mm free space from the metal around the antenna including the area below the antenna. If a metal enclosure is required, NINA-B221 with antenna pin must be used.

It is recommended to place the NINA-B222 module so that the internal antenna is in the corner of the host PCB (Pin 15/16 should be in the corner) as shown in Figure 7. The antenna side (short side closest to the antenna), positioned along one side of the host PCB ground plane is the second-best option. It is beneficial to have a large ground plane on the host PCB and have a good grounding on the NINA-B2 module.

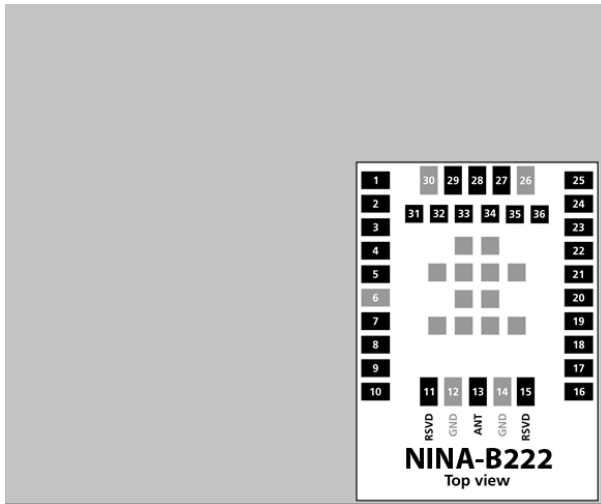

Figure 7: NINA-B222 with internal antenna

- Take care while handling the EVK-NINA-B222. Applying force to the module might damage the internal antenna.

3.4 Data communication interfaces

3.4.1 Asynchronous serial interface (UART) design

The layout of the UART bus should be done so that noise injection and cross talk are avoided. It is recommended to use the hardware flow control with RTS/CTS to prevent temporary UART buffer overrun.

The **RTS/CTS** flow control signals are active low, which means that a 0 (ON state = low level) allows the UART to transmit.

- **CTS** is an input to the NINA-B2 module. If the host sets this signal to 0 (ON state = low level) the module is allowed to transmit.
- **RTS** is an output signal from the NINA-B2 module. The module sets this signal to a 0 (ON state = low level) when it is ready to receive transmission.

3.5 General High Speed layout guidelines

These general design guidelines are considered as best practices and are valid for any bus present in the NINA-B2 series modules; the designer should prioritize the layout of higher speed busses. Low frequency signals are generally not critical for layout.

- One exception is represented by High Impedance traces (such as signals driven by weak pull resistors) that may be affected by crosstalk. For those traces, a supplementary isolation of 4w from other busses is recommended.

3.5.1 General considerations for schematic design and PCB floor-planning

- Verify which signal bus requires termination and add series resistor terminations to the schematics.
- Carefully consider the placement of the module with respect to antenna position and host processor.
- Verify with PCB manufacturer allowable stack-ups and controlled impedance dimensioning.
- Verify that the power supply design and power sequence are compliant with the specification of NINA-B2 series module.

3.5.2 Module placement

- Accessory parts like bypass capacitors should be placed as close as possible to the module to improve filtering capability, prioritizing the placement of the smallest size capacitor close to module pads.

-  Particular care should be taken not to place components close to the antenna area. The designer should carefully follow the recommendations from the antenna manufacturer about the distance of the antenna vs. other parts of the system. The designer should also maximize the distance of the antenna to Hi-frequency busses like DDRs and related components or consider an optional metal shield to reduce interferences that could be picked up by the antenna thus reducing the module's sensitivity.
- An optimized module placement allows better RF performance. For more information about antenna considerations during module placement, see also [Antenna interfaces](#) .

3.5.3 Layout and manufacturing

- Avoid stubs on high-speed signals. Even through-hole vias may have an impact on signal quality.
- Verify the recommended maximum signal skew for differential pairs and length matching of buses.
- Minimize the routing length; longer traces will degrade signal performance. Ensure that maximum allowable length for high-speed busses is not exceeded.
- Ensure that you track your impedance matched traces. Consult with your PCB manufacturer early in the project for proper stack-up definition.
- RF and digital sections should be clearly separated on the board.
- Ground splitting is not allowed below the module.
- Minimize bus length to reduce potential EMI issues from digital busses.
- All traces (including low speed or DC traces) must couple with a reference plane (GND or power); Hi-speed busses should be referenced to the ground plane. In this case, if the designer needs to change the ground reference, an adequate number of GND vias must be added in the area of transition to provide a low impedance path between the two GND layers for the return current.
- Hi-Speed busses are not allowed to change reference plane. If a reference plane change is unavoidable, some capacitors should be added in the area to provide a low impedance return path through the different reference planes.
- Trace routing should keep a distance greater than 3W from the ground plane routing edge.
- Power planes should keep a distance from the PCB edge sufficient to route a ground ring around the PCB, the ground ring must then be connected to other layers through vias.

3.6 Module footprint and paste mask

The mechanical outline of NINA-B2 series modules can be found in the NINA-B2 series data sheet [2]. The proposed land pattern layout reflects the pads layout of the module.

The Non-Solder Mask Defined (NSMD) pad type is recommended over the Solder Mask Defined (SMD) pad type, which implements the solder mask opening 50 μm larger per side than the corresponding copper pad.

It is advisable to follow the copper mask layout described in the NINA-B2 series data sheet [2] .

These are recommendations only and not specifications. The exact mask geometries, distances, and stencil thicknesses must be adapted to the specific production processes of the customer.

3.7 Thermal guidelines

NINA-B2 series modules have been successfully tested in -40 °C to +85 °C. A good grounding should be observed for temperature relief during high ambient temperature.

3.8 ESD guidelines

The immunity of devices integrating NINA-B2 modules to Electro-Static Discharge (ESD) is part of the Electro-Magnetic Compatibility (EMC) conformity, which is required for products bearing the CE marking, compliant with the R&TTE Directive (99/5/EC), the EMC Directive (89/336/EEC) and the Low Voltage Directive (73/23/EEC) issued by the Commission of the European Community.

Compliance with these directives implies conformity to the following European Norms for device ESD immunity: ESD testing standard *CENELEC EN 61000-4-2* and the radio equipment standards *ETSI EN 301 489-1*, *ETSI EN 301 489-7*, *ETSI EN 301 489-24*, the requirements of which are summarized in Table 7.

The ESD immunity test is performed at the enclosure port, defined by *ETSI EN 301 489-1* as the physical boundary through which the electromagnetic field radiates. If the device implements an integral antenna, the enclosure port is seen as all insulating and conductive surfaces housing the device. If the device implements a removable antenna, the antenna port can be separated from the enclosure port. The antenna port includes the antenna element and its interconnecting cable surfaces.

The applicability of ESD immunity test to the whole device depends on the device classification as defined by *ETSI EN 301 489-1*. Applicability of ESD immunity test to the related device ports or the related interconnecting cables to auxiliary equipment, depends on the device accessible interfaces and manufacturer requirements, as defined by the *ETSI EN 301 489-1*.

Contact discharges are performed at conductive surfaces, while air discharges are performed at insulating surfaces. Indirect contact discharges are performed on the measurement setup horizontal and vertical coupling planes as defined in the *CENELEC EN 61000-4-2*.

For the definition of integral antenna, removable antenna, antenna port, and device classification, refer to the *ETSI EN 301 489-1*. For the contact and air discharges definitions, refer to *CENELEC EN 61000-4-2*.

Parameter	Min.	Typical	Max.	Unit	Remarks
ESD immunity. All exposed surfaces of the radio equipment and ancillary equipment in a representative configuration			8*	kV	Indirect discharge according to IEC 61000-4-2
ESD sensitivity, tested for all pins except ANT and RSVD pins #11, #15, and #33			2.0	kV	Human body model according to JEDEC JS001

* Tested on EVK-NINA-W1 evaluation board.

Table 7: Electro-Magnetic Compatibility ESD immunity requirements as defined by CENELEC EN 61000-4-2, ETSI EN 301 489-1, ETSI EN 301 489-7, ETSI EN 301 489-24

NINA-B2 is manufactured with due consideration to specific standards that minimize the occurrence of ESD events; the highly automated process complies with the IEC61340-5-1 (STM5.2-1999 Class M1 devices) standard. The designer should implement proper measures to protect from ESD events any pin that may be exposed to the end user.

Compliance with standard protection level specified in the EN61000-4-2 can be achieved by including the ESD protections in parallel to the line – close to areas accessible by the end user.

4 Handling and soldering

No natural rubbers, hygroscopic materials or materials containing asbestos are employed.

- ⚠** NINA-B2 series modules are Electrostatic Sensitive Devices that demand the observance of special handling precautions against static damage. Failure to observe these precautions can result in severe damage to the product.

4.1 ESD handling precautions

As the risk of electrostatic discharge in the RF transceivers and patch antennas of the module is of particular concern, standard ESD safety practices are prerequisite. See also Figure 8.

Consider also:

- When connecting test equipment or any other electronics to the module (as a standalone or PCB-mounted device), the first point of contact must always be to local GND.
- Before mounting an antenna patch, connect the device to ground.
- When handling the RF pin, do not touch any charged capacitors. Be especially careful when handling materials like patch antennas (~10 pF), coaxial cables (~50-80 pF/m), soldering irons, or any other materials that can develop charges.
- To prevent electrostatic discharge through the RF input, do not touch any exposed antenna area. If there is any risk of the exposed antenna being touched in an unprotected ESD work area, be sure to implement proper ESD protection measures in the design.
- When soldering RF connectors and patch antennas to the RF pin on the receiver, be sure to use an ESD-safe soldering iron (tip).

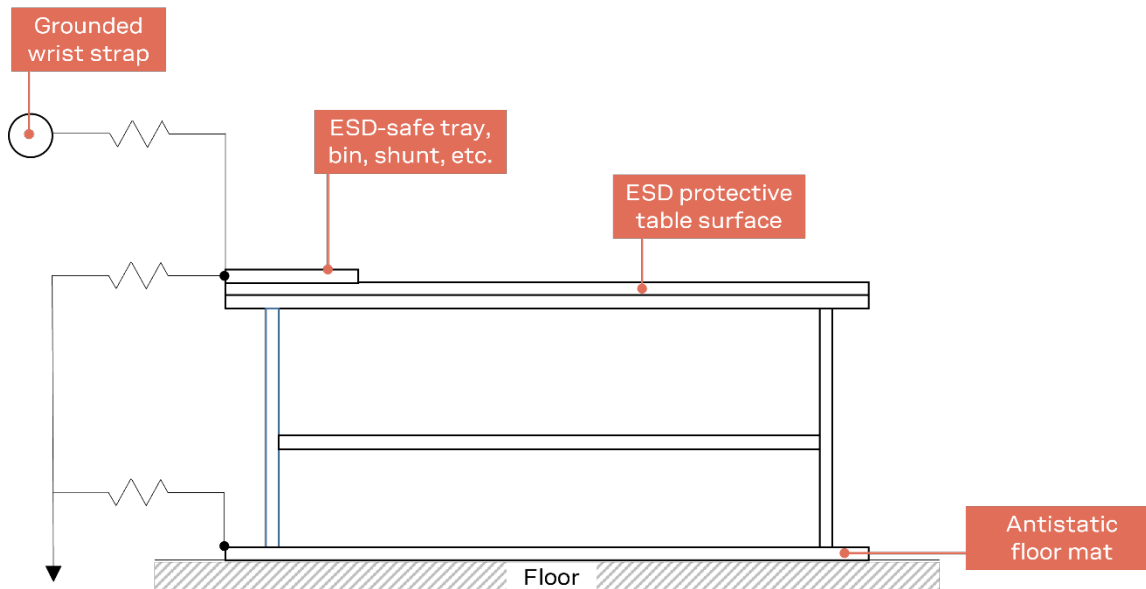

Figure 8: Standard workstation setup for safe handling of ESD-sensitive devices

4.2 Packaging, shipping, storage, and moisture preconditioning

For information pertaining to reels, tapes, or trays, moisture sensitivity levels (MSL), storage, shipment, and drying preconditioning, see the NINA-B2 series data sheet [2]. and Packaging information reference guide [3].

4.3 Reflow soldering process

NINA-B2 series modules are surface mount modules supplied on a FR4-type PCB with gold-plated connection pads. The modules are produced in a lead-free process using lead-free soldering paste. The thickness of solder resist between the top-side of the host PCB and the bottom-side of the NINA-B2 series module must be considered for the soldering process.

NINA-B2 series modules are compatible with industrial reflow profile for RoHS solders, and "No Clean" soldering paste is strongly recommended.

The reflow profile used is dependent on the thermal mass of the entire populated PCB, the heat transfer efficiency of the oven, and the particular type of solder paste that is used. The optimal soldering profile must be trimmed for the specific process and PCB layout.

Target values in Table 8 should be taken as general guidelines for a Pb-free process. For further information, see also the JEDEC J-STD-020C standard.

Process parameter		Unit	Value
Pre-heat	Ramp up rate to T_{SMIN}	K/s	3
	T_{SMIN}	°C	150
	T_{SMAX}	°C	200
	t_s (from +25 °C)	s	150
	t_s (Pre-heat)	s	60 to 120
Peak	T_L	°C	217
	t_L (time above T_L)	s	40 to 60
	T_P (absolute max)	°C	245
Cooling	Ramp-down from T_L	K/s	4
	Allowed soldering cycles	-	2

Table 8: Recommended reflow profile

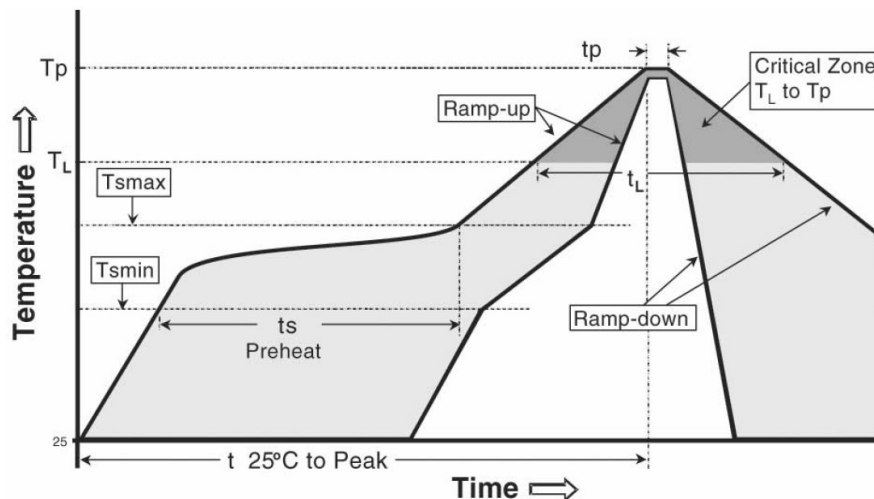

Figure 9: Reflow Profile

Lower value of T_P and slower ramp down rate (2 – 3 °C/sec) is preferred.

4.3.1 Cleaning

Cleaning the modules is not recommended. Residues underneath the modules cannot be easily removed with a washing process.

- Cleaning with water will lead to capillary effects where water is absorbed in the gap between the baseboard and the module. The combination of residues of soldering flux and encapsulated water leads to short circuits or resistor-like interconnections between neighboring pins. Water will also damage the sticker and the ink-jet printed text.
- Cleaning with alcohol or other organic solvents can result in soldering flux residues flooding into the housing, areas that are not accessible for post-wash inspections. The solvent will also damage the sticker and the ink-jet printed text.
- Ultrasonic cleaning will permanently damage the module and the crystal oscillators in particular.

For best results use a "no clean" soldering paste and circumvent the need for a cleaning stage after the soldering process.

4.3.2 Other notes

- Two reflow soldering processes are allowed for boards with a module soldered on it.
- Boards with combined through-hole technology (THT) components and surface-mount technology (SMT) devices may require wave soldering to solder the THT components. Only a single wave soldering process is allowed for boards populated with the modules. Miniature Wave Selective Solder processes are preferred over traditional wave soldering processes.
- Hand soldering is not recommended.
- Rework is not recommended.
- Conformal coating can affect the performance of the module, which means that it is important to prevent the liquid from flowing into the module. The RF shields do not provide protection for the module from coating liquids with low viscosity; therefore, care is required while applying the coating. Conformal Coating of the module will void the warranty.
- Grounding metal covers: Attempts to improve grounding by soldering ground cables, wick, or other forms of metal strips directly onto the EMI covers is done so at the customer's own risk and will void the module warranty. The numerous ground pins on the module are adequate to provide optimal immunity to interferences.
- The modules contain components which are sensitive to Ultrasonic Waves. Use of any Ultrasonic Processes (cleaning, welding, etc.) may damage the module. The use of ultrasonic processes during the integration of the module into an end product will void the warranty.

5 Approvals

For additional regulatory information, see the NINA-B2 series Datasheet [2].

5.1 General requirements

The NINA-B2 series modules comply with the regulatory demands of Federal Communications Commission (FCC), Industry Canada (IC)² and the CE mark. This section provides the instructions that must be followed by an integrator while including NINA-B2 series into an end product.

- Any changes to hardware, hosts or co-location configuration may require new radiated emission and SAR evaluation and/or testing.
- The regulatory compliance of NINA-B2 series does not exempt the end product from being evaluated against applicable regulatory demands; for example, FCC Part 15B criteria for unintentional radiators [9].
- Only authorized antenna(s) may be used.
- Any notification to the end user about how to install or remove the integrated radio module is NOT allowed.

5.2 FCC/IC End-product regulatory compliance

u-blox warrants that the modular transmitter fulfills the FCC/IC regulations when operating in authorized modes on any host product given that the integrator follows the instructions as described in this document.

5.2.1 NINA-B2 series FCC ID and IC certification number

An end product integrating the NINA-B2 series module using u-blox connectivity software can refer to the u-blox FCC ID and IC certification number.

u-blox can support updates to the u-blox regulatory authorization, if needed. For example, adding new antennas to the u-blox authorization for NINA-B2 module using the antenna pin.

5.2.2 Antenna requirements

In addition to the general requirement to use only authorized antennas, the u-blox grant also requires a separation distance of at least 20 cm from the antenna to all persons. Also, the antenna must not be co-located with any other antenna or transmitter (simultaneous transmission) as well. If this cannot be met, a Permissive Change as described below must be made to the grant.

5.2.2.1 Separation distance

If the required separation distance of 20 cm cannot be fulfilled, a SAR evaluation must be performed. This consists of additional calculations and/or measurements. The result must be added to the grant file as a Class II Permissive Change.

5.2.2.2 Co-location (simultaneous transmission)

If the module is to be co-located with another transmitter, additional measurements for simultaneous transmission is required. The results must be added to the grant file as a Class II Permissive Change.

² Official name is Innovation, Science and Economic Development (ISED) Canada.

5.2.2.3 Adding a new antenna for authorization

If the authorized antennas and/or antenna trace design cannot be used, the new antenna and/or antenna trace designs must be added to the grant file. This is done by a Class I Permissive Change or a Class II Permissive Change, depending on the specific antenna and antenna trace design.

- Antennas of the same type and with less or same gain as an already approved antenna can be added under a Class I Permissive Change.
- Antenna trace designs deviating from the u-blox reference design and new antenna types are added under a Class II Permissive Change.

 Integrators who want to refer to the u-blox FCC ID / IC certification ID must [contact](#) their local support team to discuss the Permissive Change Process. Class II Permissive Changes will be subject to NRE costs.

6 Product testing

6.1 u-blox in-line production testing

As part of our focus on high quality products, u-blox maintain stringent quality controls throughout the production process. This means that all units in our manufacturing facilities are fully tested and that any identified defects are carefully analyzed to improve future production quality.

The Automatic test equipment (ATE) deployed in u-blox production lines logs all production and measurement data – from which a detailed test report for each unit can be generated. Figure 10 shows the ATE typically used during u-blox production.

u-blox in-line production testing includes:

- Digital self-tests (firmware download, MAC address programming)
- Measurement of voltages and currents
- Functional tests (host interface communication)
- Digital I/O tests
- Measurement and calibration of RF characteristics in all supported bands, including RSSI calibration, frequency tuning of reference clock, calibration of transmitter power levels, etc.
- Verification of Wi-Fi and Bluetooth RF characteristics after calibration, like modulation accuracy, power levels, and spectrum, are checked to ensure that all characteristics are within tolerance



Figure 10: Automatic test equipment for module test

6.2 OEM manufacturer production test

As all u-blox products undergo thorough in-series production testing prior to delivery, OEM manufacturers do not need to repeat any firmware tests or measurements that might otherwise be necessary to confirm RF performance. Testing over analog and digital interfaces is also unnecessary during an OEM production test.

OEM manufacturer testing should ideally focus on:

- Module assembly on the device; it should be verified that:
 - Soldering and handling process did not damage the module components
 - All module pins are well soldered on application board
 - There are no short circuits between pins
- Component assembly on the device; it should be verified that:
 - Communication with host controller can be established
 - The interfaces between module and device are working
 - Overall RF performance test of the device including antenna

In addition to this testing, OEMs can also perform other dedicated tests to check the device. For example, the measurement of module current consumption in a specified operating state can identify a short circuit if the test result deviates that from that taken against a “Golden Device”.

The standard operational module firmware and test software on the host can be used to perform functional tests (communication with the host controller, check interfaces) and perform basic RF performance testing. Special manufacturing firmware can also be used to perform more advanced RF performance tests.

6.2.1 “Go/No go” tests for integrated devices

A “Go/No go” test compares the signal quality with a “Golden Device” in a location with known signal quality. This test can be performed after establishing a connection with an external device.

A very simple test can be performed by just scanning for a known Bluetooth low energy device and checking the signal level.

These kinds of test may be useful as a “go/no go” test but not for RF performance measurements.

This test is suitable to check the functionality of the communication with the host controller and the power supply. It is also a means to verify if the components are well soldered.

A basic RF functional test of the device including the antenna can be performed with standard Bluetooth low energy devices as remote stations. The device containing the NINA-B2 series module and the antennas should be arranged in a fixed position inside an RF shield box to prevent interferences from other possible radio devices to get stable test results.

Appendix

A Glossary

Abbreviation	Definition
AFA	Automatic Frequency Adaption
AP	Access Point
ATE	Automatic Test Equipment
BP	Band Pass
BPF	Band Pass Filter
BT	Bluetooth
CAN	Controller Area Network
CPU	Central Processing Unit
CTS	Clear To Send
DC	Direct Current
DDR	Double Data Rate
DSR	Data Set Ready
DTR	Data Terminal Ready
EIRP	Equivalent Isotropically Radiated Power
EMC	Electro-magnetic Compatibility
EMI	Electromagnetic Interference
ESD	Electro-Static Discharge
GND	Ground
IoT	Internet of Things
ISM	Industrial, Scientific, and Medical radio
LED	Light-Emitting Diode
LTE	Long-Term Evolution
MAC	Media Access Control
MCU	Microcontroller
MCS	Modulation Coding Scheme
MISO	Master Input Slave Output
MOSI	Master Output Slave Input
MSL	Moisture Sensitivity Level
NSMD	Non Solder Mask Defined
OEM	Original Equipment Manufacturer
PCB	Printed Circuit Board
RF	Radio Frequency
ROM	Read-only Memory
RMII	Reduced Media-independent Interface
RSSI	Received Signal Strength Indicator
RTC	Real-Time Clock
SMA	SubMiniature version A
SPI	Serial Peripheral Interface
SRAM	Static random-access memory
THT	Through-hole Technology
UART	Universal Asynchronous Receiver-Transmitter

Table 9: Explanation of abbreviations used

Related documents

- [1] u-connectXpress AT commands manual, [UBX-14044127](#)
- [2] NINA-B2 series data sheet, [UBX-18006649](#)
- [3] Packaging information reference, [UBX-14001652](#)
- [4] EVK-NINA-W1/EVK-NINA-B2 user guide, [UBX-17011007](#)
- [5] u-connectXpress user guide, [UBX-16024251](#)
- [6] s-center user guide, [UBX-16012261](#)
- [7] Communicating with a u-blox module over SPI bus, application note, [UBX-20028725](#)
- [8] u-connectXpress bootloader protocol specification, [UBX-17065404](#)

 For product change notifications and regular updates of u-blox documentation, register on our website, www.u-blox.com.

Revision history

Revision	Date	Name	Comments
R01	27-Apr-2018	fbro, kgom	Initial release.
R02	3-Jul-2018	cmag, kgom	Modified the product status to Engineering Sample on page 2. Provided reference to NINA-B2 Getting Started.
R03	28-Jan-2019	fbro, mwej	Modified the product status to Initial Production. Removed support for external LPO clock (section 1.4.1). Updated block diagram (Figure 1). Updated Output power data (Table 1). Removed pending status for FCC/IC approval in section 5.
R04	17-Dec-2019	flun	Cleaned up Applicable Products section.
R05	18-Sep-2020	flun	Added SPI in section 1.7.2. Updated ESD Updated boot strapping pins in section 1.6.1, and clarified RTS/CTS pins in section 1.7.1. Updated the Glossary, Related documents and applicable products featured in the Document information section.
R06	01-Nov-2021	lkis	Updated approved reflow soldering cycle to two in Reflow soldering process . Updated Software chapter and all sub-sections. Added programming methods in detail. Revised Product testing and Handling and soldering and information, including the removal of the earlier requirements for bow and twist on bare PCBs. Revised maximum ESD sensitivity in ESD guidelines .

Contact

For complete contact information, visit us at www.u-blox.com.

u-blox Offices

North, Central and South America

u-blox America, Inc.

Phone: +1 703 483 3180
E-mail: info_us@u-blox.com

Regional Office West Coast:

Phone: +1 408 573 3640
E-mail: info_us@u-blox.com

Technical Support:

Phone: +1 703 483 3185
E-mail: support@u-blox.com

Headquarters

Europe, Middle East, Africa

u-blox AG

Phone: +41 44 722 74 44
E-mail: info@u-blox.com
Support: support@u-blox.com

Asia, Australia, Pacific

u-blox Singapore Pte. Ltd.

Phone: +65 6734 3811
E-mail: info_ap@u-blox.com
Support: support_ap@u-blox.com

Regional Office Australia:

Phone: +61 3 9566 7255
E-mail: info_anz@u-blox.com
Support: support_ap@u-blox.com

Regional Office China (Beijing):

Phone: +86 10 68 133 545
E-mail: info_cn@u-blox.com
Support: support_cn@u-blox.com

Regional Office China (Chongqing):

Phone: +86 23 6815 1588
E-mail: info_cn@u-blox.com
Support: support_cn@u-blox.com

Regional Office China (Shanghai):

Phone: +86 21 6090 4832
E-mail: info_cn@u-blox.com
Support: support_cn@u-blox.com

Regional Office China (Shenzhen):

Phone: +86 755 8627 1083
E-mail: info_cn@u-blox.com
Support: support_cn@u-blox.com

Regional Office India:

Phone: +91 80 405 092 00
E-mail: info_in@u-blox.com
Support: support_in@u-blox.com

Regional Office Japan (Osaka):

Phone: +81 6 6941 3660
E-mail: info_jp@u-blox.com
Support: support_jp@u-blox.com

Regional Office Japan (Tokyo):

Phone: +81 3 5775 3850
E-mail: info_jp@u-blox.com
Support: support_jp@u-blox.com

Regional Office Korea:

Phone: +82 2 542 0861
E-mail: info_kr@u-blox.com
Support: support_kr@u-blox.com

Regional Office Taiwan:

Phone: +886 2 2657 1090
E-mail: info_tw@u-blox.com
Support: support_tw@u-blox.com