

DESCRIPTION: MALE - DIP SOLDER - MACHINED - ECONOMY

No. OF PINS	DIMENSIONS					
	A	B	C	D	E	F
9	1.213	0.984	0.666	0.329	0.236	0.496
	30.80	24.99	16.92	8.36	5.99	12.60
15	1.541	1.312	0.994	0.329	0.236	0.496
	39.15	33.32	25.25	8.36	5.99	12.60
25	2.087	1.852	1.534	0.329	0.236	0.496
	53.00	47.04	38.96	8.36	5.99	12.60

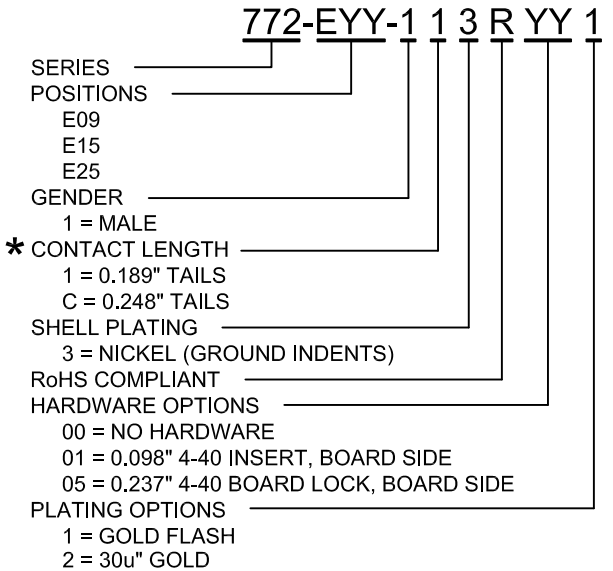
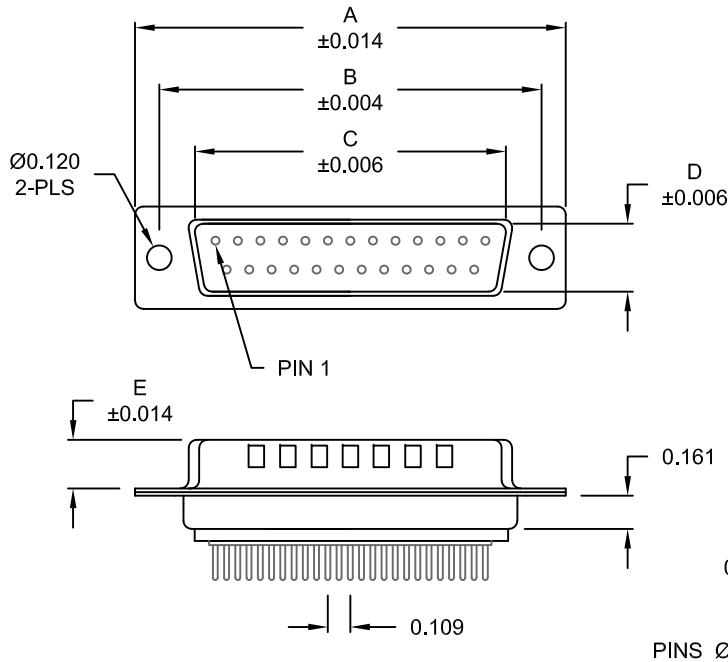

**MATERIAL:**

- SHELL: STEEL, NICKEL PLATED
- INSULATOR: UL 94V-O RATED, WHITE PA6T
- PROCESS TEMP.: 260° C
- CONTACT: BRASS
- SEALING MATERIAL: F08 FLEXIBLE ADHESIVE

**MEETS IP67 STANDARDS**

(SEE PAGE 3 FOR SEALING DETAILS)

UNITS = inch [mm]

**ELECTRICAL:**

- CURRENT RATING: 5 AMPS
- CONTACT RESISTANCE: 15 mOhms Max.
- INSULATION RESISTANCE: 1,000 MOhms min.
- VOLTAGE: 500VAC FOR 1 MINUTE
- TEMPERATURE: -50° C TO 100° C

DO NOT SCALE FROM DRAWING

	THESE DRAWINGS AND SPECIFICATIONS ARE THE PROPERTY OF NorComp AND SHALL NOT BE REPRODUCED, COPIED OR USED AS THE BASIS FOR THE MANUFACTURE OF SALE OF APPARATUS WITHOUT WRITTEN PERMISSION.	DRAWN: PAM JENKINS	DATE: 9-18-08
		SCALE: NTS	SHEET 1 OF 3
<b>NorComp</b>		DWG NO. 772-EYY-113RYY1	

RoHS COMPLIANT

DESCRIPTION: PCB LAYOUT - STANDARD "D"

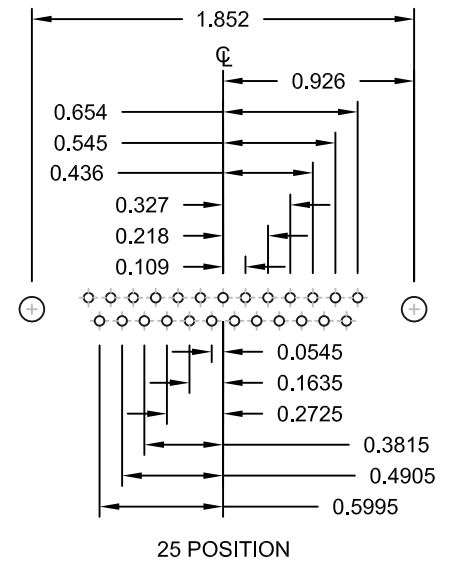
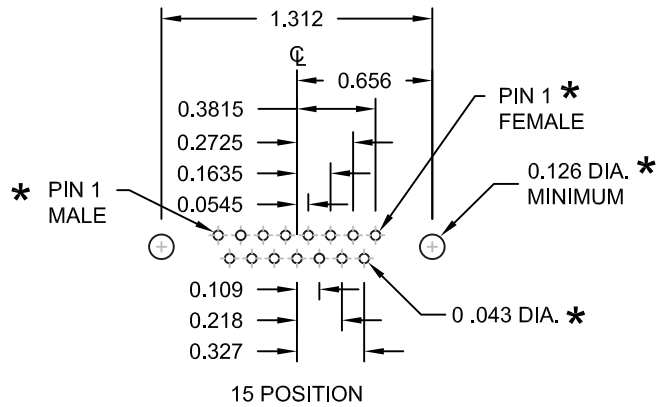
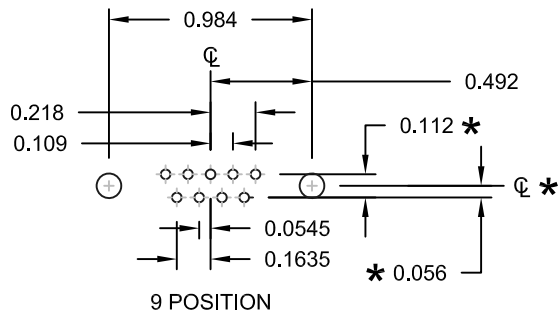

\* TYP.  
SUGGESTED SIZE  
MAY NOT BE SUITABLE FOR ALL APPLICATIONS

UNITS = inch [mm]

DO NOT SCALE FROM DRAWING

	THESE DRAWINGS AND SPECIFICATIONS ARE THE PROPERTY OF NorComp AND SHALL NOT BE REPRODUCED, COPIED OR USED AS THE BASIS FOR THE MANUFACTURE OF SALE OF APPARATUS WITHOUT WRITTEN PERMISSION.		DRAWN: PAM JENKINS	DATE: 9-18-08
	<h1>NorComp</h1>		SCALE: NTS	SHEET 2 OF 3
DWG NO. 772-EYY-113RYY1				

DESCRIPTION: IP67 - MALE - SOLDER CUP - MACHINED - ECONOMY - SEALING PROCESS

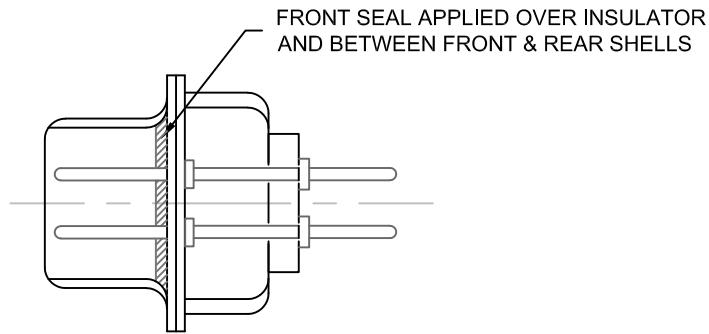
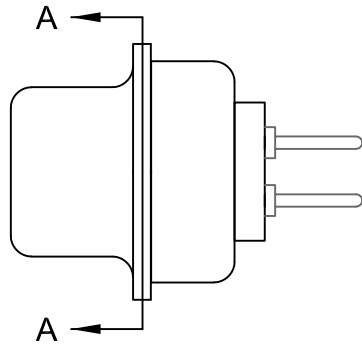

DETAIL A-A

### HARDWARE OPTIONS

ALL CLINCH-NUTS ARE 4-40 INTERNAL THREADS

01X ..... 0.098" (BOARD SIDE)

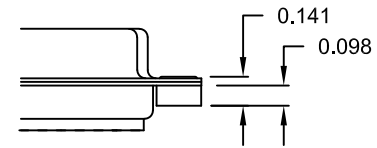

05X ..... 0.237" (BOARD SIDE)

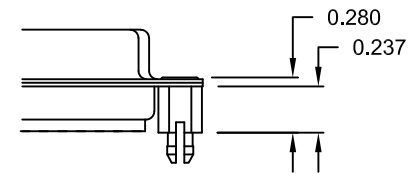

UNITS = inch [mm]

DO NOT SCALE FROM DRAWING



THESE DRAWINGS AND SPECIFICATIONS ARE THE PROPERTY OF NorComp AND SHALL NOT BE REPRODUCED, COPIED OR USED AS THE BASIS FOR THE MANUFACTURE OF SALE OF APPARATUS WITHOUT WRITTEN PERMISSION.

DRAWN:  
PAM JENKINS

DATE:  
9-18-08

# NorComp

SCALE: NTS	SHEET 3	OF 3	REV 5
---------------	------------	---------	----------

DWG NO. 772-EYY-113RYY1