

REVISIONS				
REV	ECO	DESCRIPTION	DATE	BY APPR
A1	-	RELEASED DRAWING	Jul-16-18	Flan Tommy

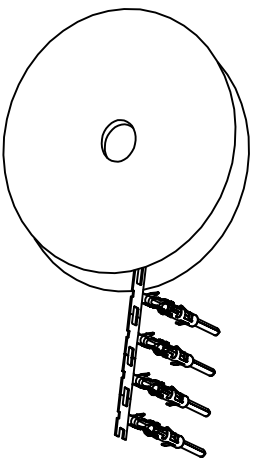

CONTACT ORIENTATION ON ROLL(3000PCS/COIL)

NOTES : (UNLESS OTHERWISE SPECIFIED)

- MATERIAL :
 - CONTACT BODY : COPPER ALLOY.
 - OUTER SPRING : STAINLESS STEEL.
- SPECIFICATIONS :
 - CURRENT RATING : 13A MAX.
 - TERMINATION TYPE : CRIMPING.
 - WIRE RANGE : 22~20AWG.
 - WIRE INSULATION DIA(MAX) : ϕ 2.5mm.
- RoHS COMPLIANT.
- ALL DIMENSIONS ARE FOR REFERENCE USE ONLY.
- AVAILABLE TOOLS :
 - HAND CRIMPER : MFX-3954.
 - CRIMP APPLICATOR : MFX-3957.
 - EXTRACTION TOOL : QXRT16.

P/N	CONTACT PLATING(MATING AREA)
SP20M2T	TIN PLATING OVER NICKEL.
SP20M2N	NICKEL PLATING OVER COPPERIZE.
SP20M2F	GOLD FLASH PLATING OVER NICKEL.
SP20M2G5	5 μ "GOLD PLATING OVER NICKEL.
SP20M2G10	10 μ "GOLD PLATING OVER NICKEL.
SP20M2G15	15 μ "GOLD PLATING OVER NICKEL.
SP20M2G30	30 μ "GOLD PLATING OVER NICKEL.

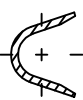
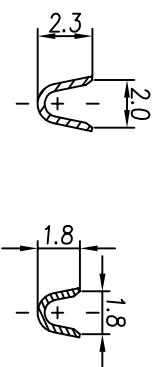
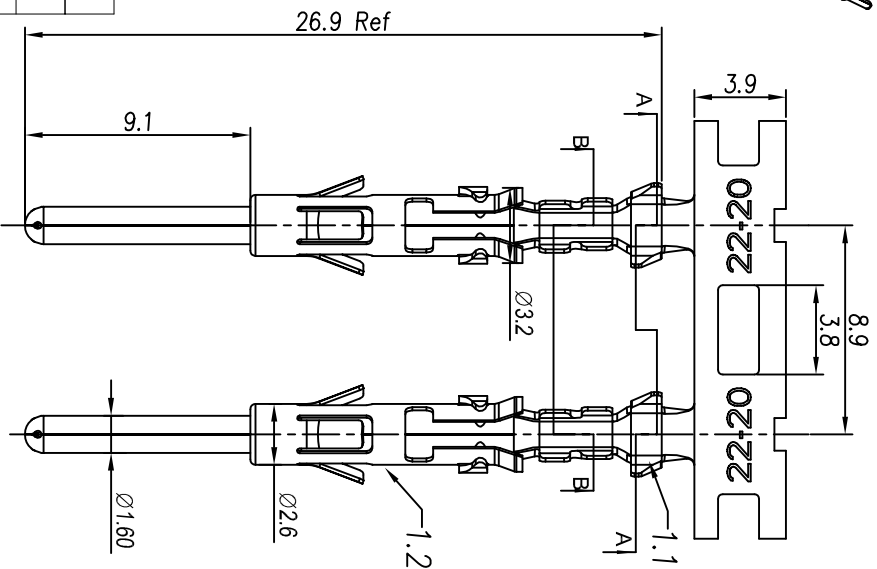

SECTION A-A

QUANTITY	PART NUMBER	DESCRIPTION	ITEM
MATERIALS LIST			
UNLESS OTHERWISE SPECIFIED 1) All dimensions are in millimeters. 2) Tolerances are as follows: 1 PL DEC 20.30 Fractions 1/16" 3 PL DEC 20.08 Fractions 1/16" 3) Note reference =			
PROCESS SPECIFICATIONS:		MATERIAL SPECIFICATIONS:	
DRAWN: Flan		CUSTOMER: Tommy	
CHECKED: Jod		APPROVAL: Jul-16-18	
ENGINEER: Jod		DATE: Jul-16-18	
SIGNATURES:		DATE:	
DRAWN: Flan		DATE: Jul-16-18	
CHECKED: Jod		DATE: Jul-16-18	
ENGINEER: Jod		DATE: Jul-16-18	
APPROVAL: Tommy		DATE: Jul-16-18	
THIS DRAWING IS SUPERSEDED BY THE LATEST REVISIONS. SPECIFICATIONS AND PERFORMANCE DATA ARE SUBJECT TO CHANGE WITHOUT NOTICE. THE MANUFACTURING CORPORATION ASSUMES NO RESPONSIBILITY FOR REPRODUCTION AND ILLUSTRATION. ALL DIMENSIONS AND TOLERANCES ARE IN MILLIMETERS UNLESS OTHERWISE SPECIFIED.			
SCALE: NONE		SCALE: NONE	
SIZE: B		SIZE: B	
TYPE: C-		TYPE: C-	
DRAWING NO: SP20M2XX		DRAWING NO: SP20M2XX	
REVISION: A1		REVISION: A1	

