

NOTE:  
22.5 MAX RAIL TO RAIL  
12.5 MIN RAIL TO RAIL

UNLESS OTHERWISE SPECIFIED:  
DIMENSIONS ARE IN INCHES  
TOLERANCES:  
FRACTIONAL: ±1/8  
ANGULAR: BEND ±1 DEGREE  
TWO PLACE DECIMAL ±.03  
THREE PLACE DECIMAL ±.01

<b>WEB PRINT</b>	
NEXT ASSY	USED ON
APPLICATION	

MATERIAL	DO NOT SCALE DRAWING
FINISH	

NAME	DATE
DRAWN	
CHECKED	
ENG APPR.	
MFG APPR.	
Q.A.	
COMMENTS:	

**KENDALL HOWARD**

TITLE:  
**18U LINIER WM SWINGOUT CABINET- PERFORATED DOOR**

SIZE	DWG. NO.	REV
<b>A</b>	<b>3132-3-001-18 WP</b>	

SCALE: 1:10 WEIGHT: 72.50 SHEET 1 OF 2

**PROPRIETARY AND CONFIDENTIAL**  
THE INFORMATION CONTAINED IN THIS DRAWING IS THE SOLE PROPERTY OF KENDALL HOWARD. ANY REPRODUCTION IN PART OR AS A WHOLE WITHOUT THE WRITTEN PERMISSION OF KENDALL HOWARD IS STRICTLY PROHIBITED.

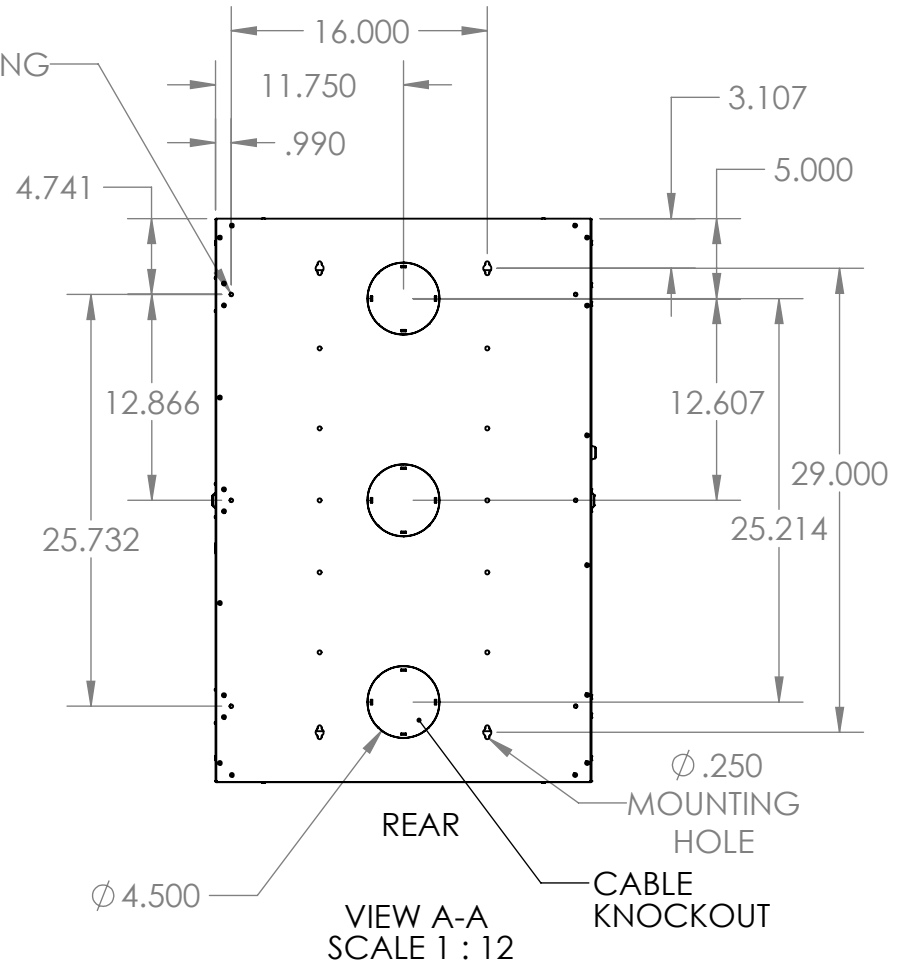
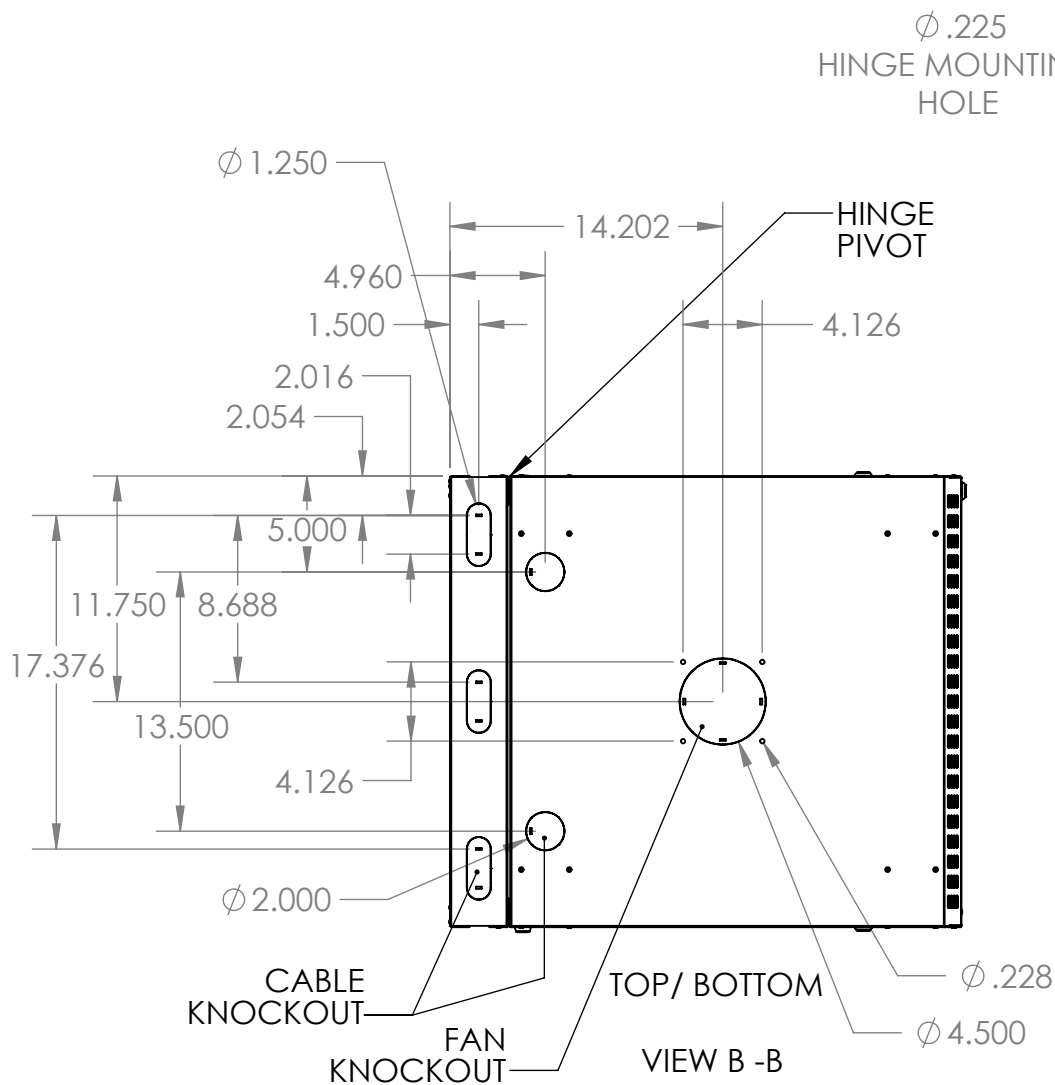

UNLESS OTHERWISE SPECIFIED:  
 DIMENSIONS ARE IN INCHES  
 TOLERANCES:  
 FRACTIONAL  $\pm 1/8$   
 ANGULAR: BEND  $\pm 1$  DEGREE  
 TWO PLACE DECIMAL  $\pm .03$   
 THREE PLACE DECIMAL  $\pm .01$

**WEB PRINT**

**PROPRIETARY AND CONFIDENTIAL**  
 THE INFORMATION CONTAINED IN THIS DRAWING IS THE SOLE PROPERTY OF KENDALL HOWARD. ANY REPRODUCTION IN PART OR AS A WHOLE WITHOUT THE WRITTEN PERMISSION OF KENDALL HOWARD IS STRICTLY PROHIBITED.

NEXT ASSY		USED ON	MATERIAL
APPLICATION		DO NOT SCALE DRAWING	FINISH

	NAME	DATE
DRAWN		
CHECKED		
ENG APPR.		
MFG APPR.		
Q.A.		
COMMENTS:		

**KENDALL HOWARD**  INC.  
 TITLE:  
**18U LINIER WM SWINGOUT CABINET- PERFORATED DOOR**  
 SIZE DWG. NO. REV  
**A** 3132-3-001-18 WP  
 SCALE: 1:10 WEIGHT: 72.50 SHEET 2 OF 2