

REVISIONS					
P.	LTH	DESCRIPTION	DATE	DMN	APVD
B		REVISED PER ECR-14-004138	18MAR2014	MM	SB

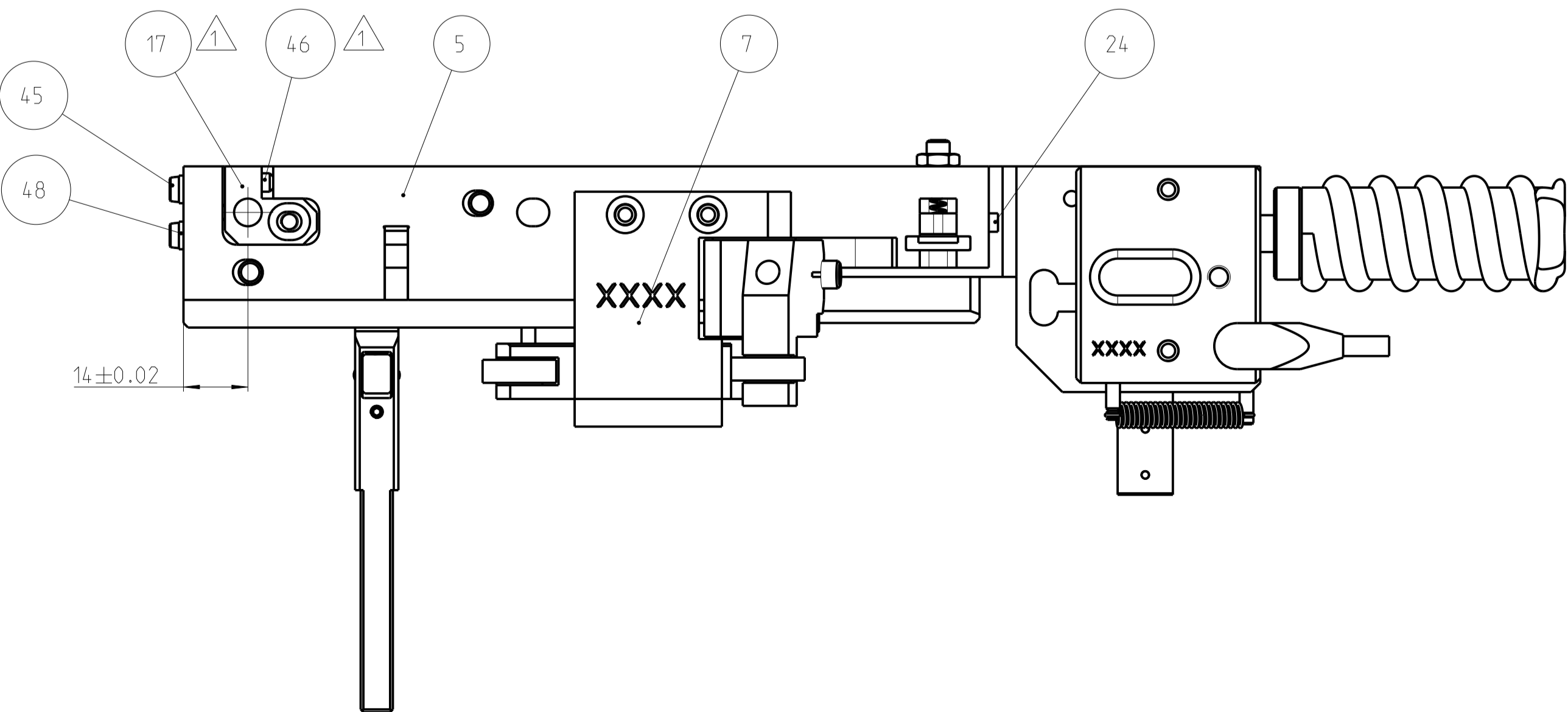
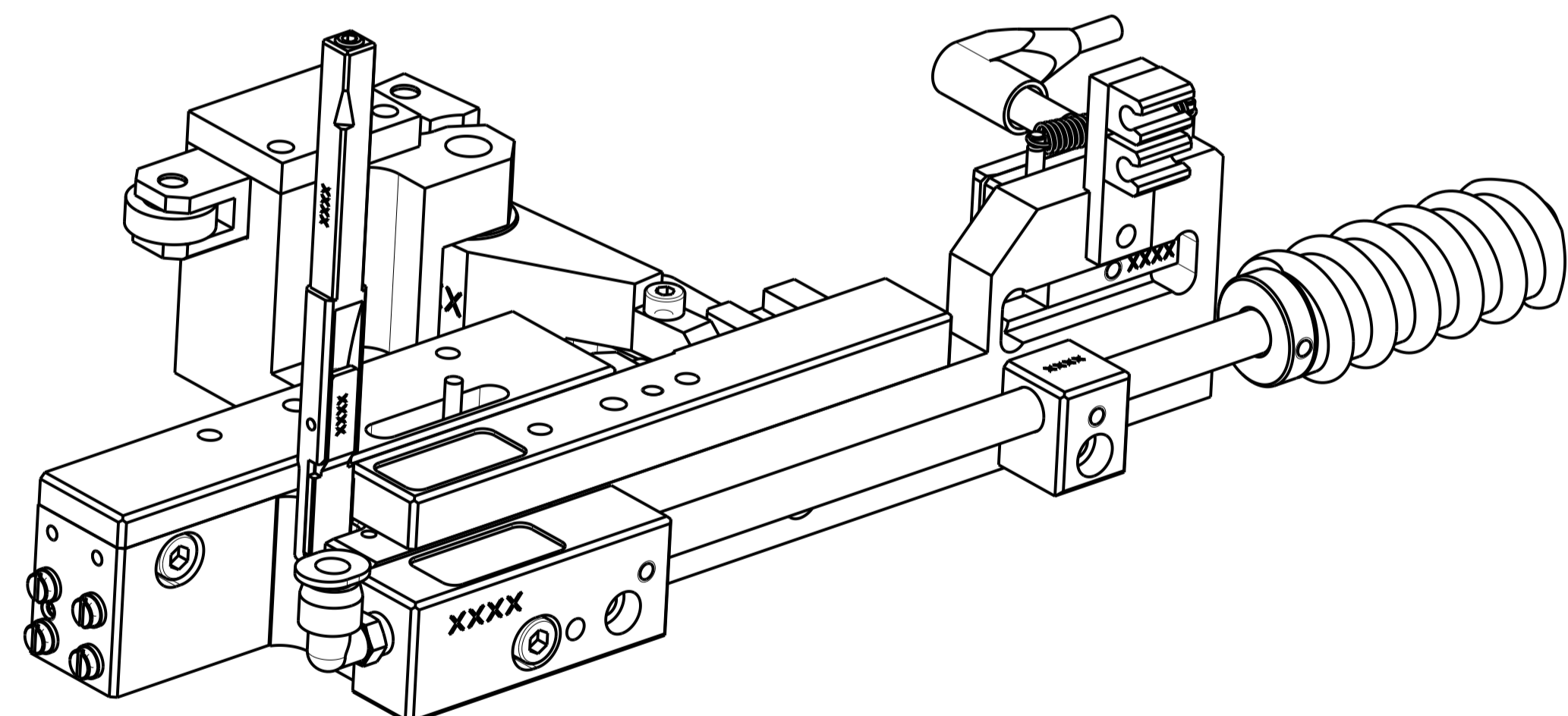
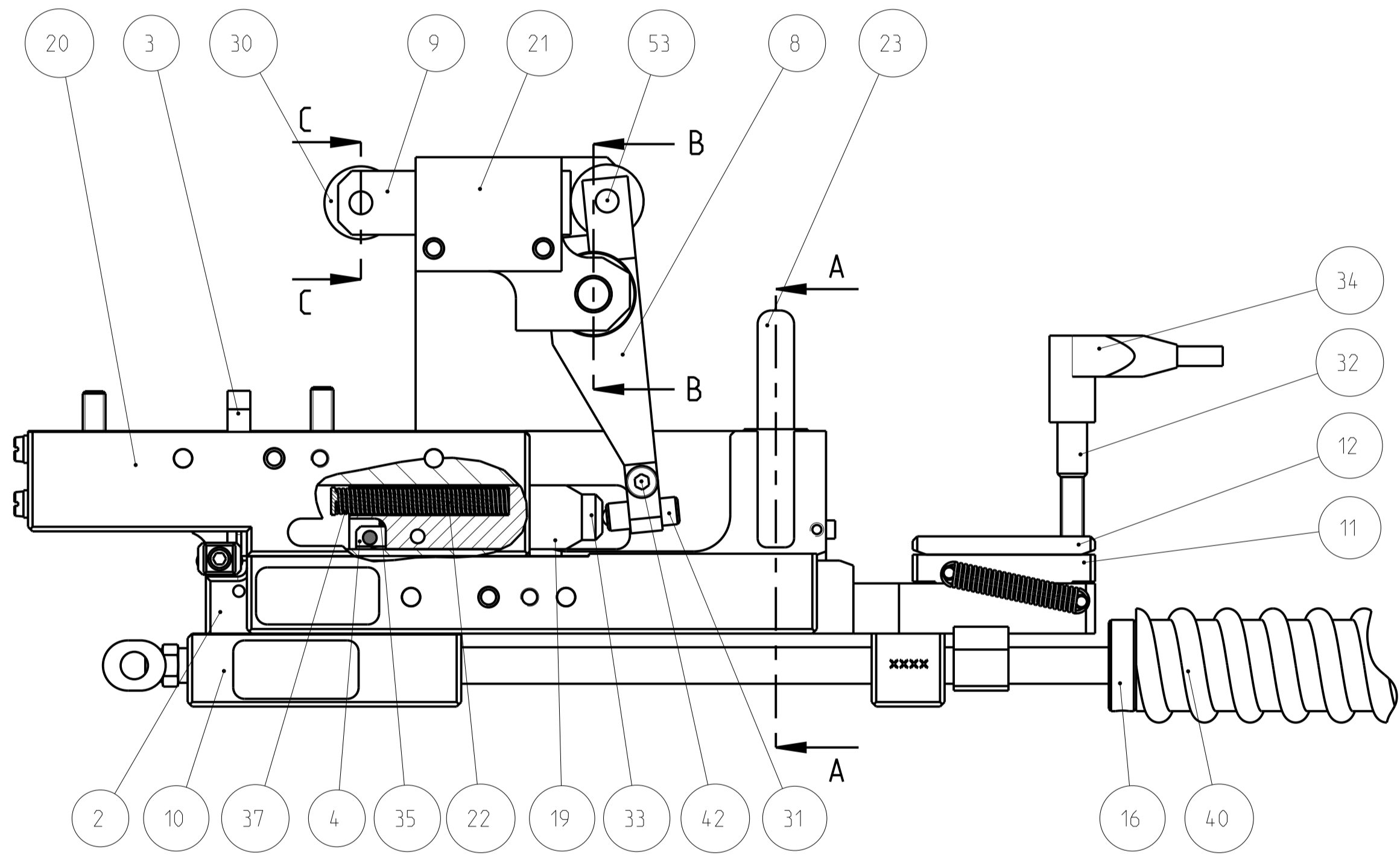
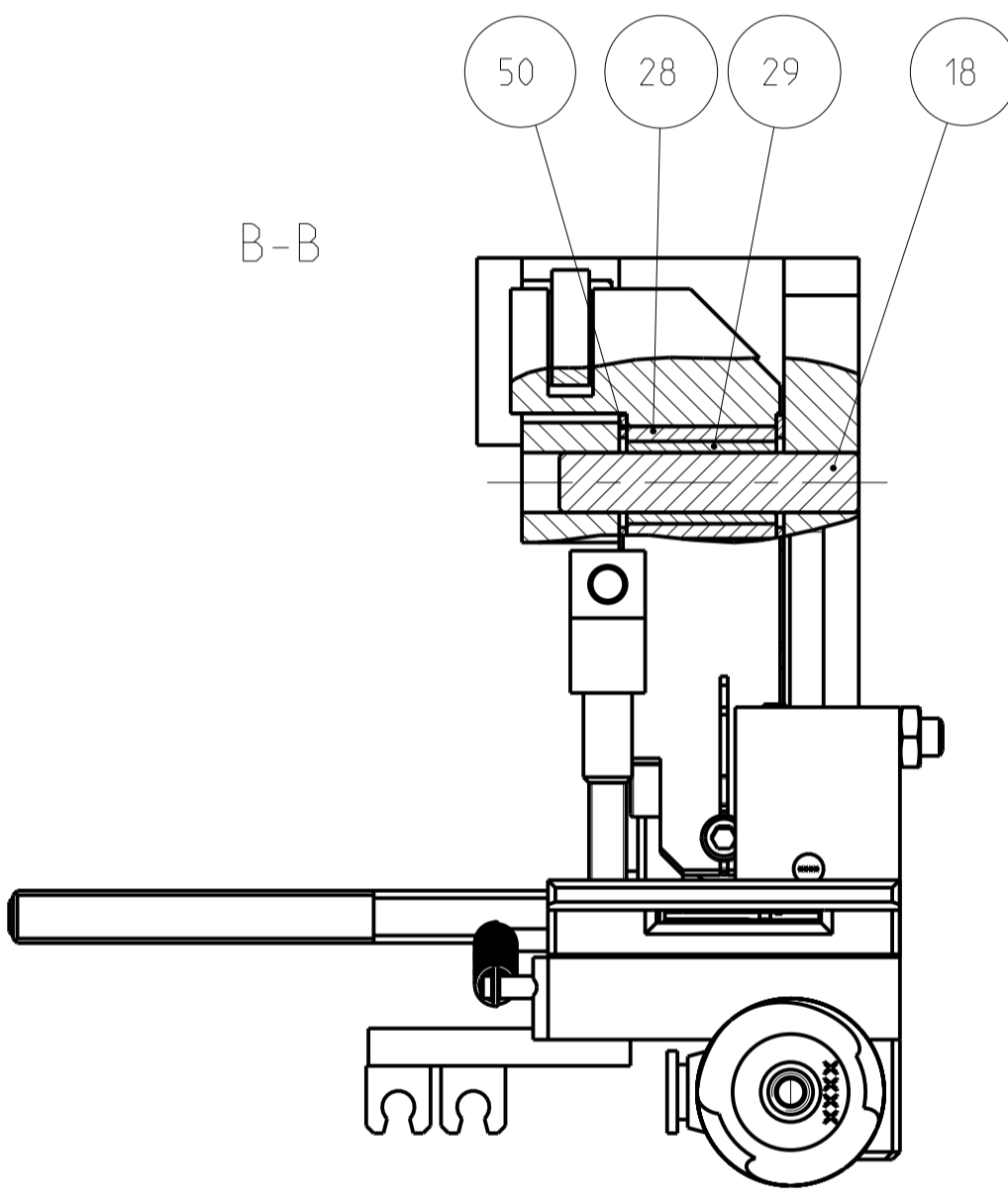
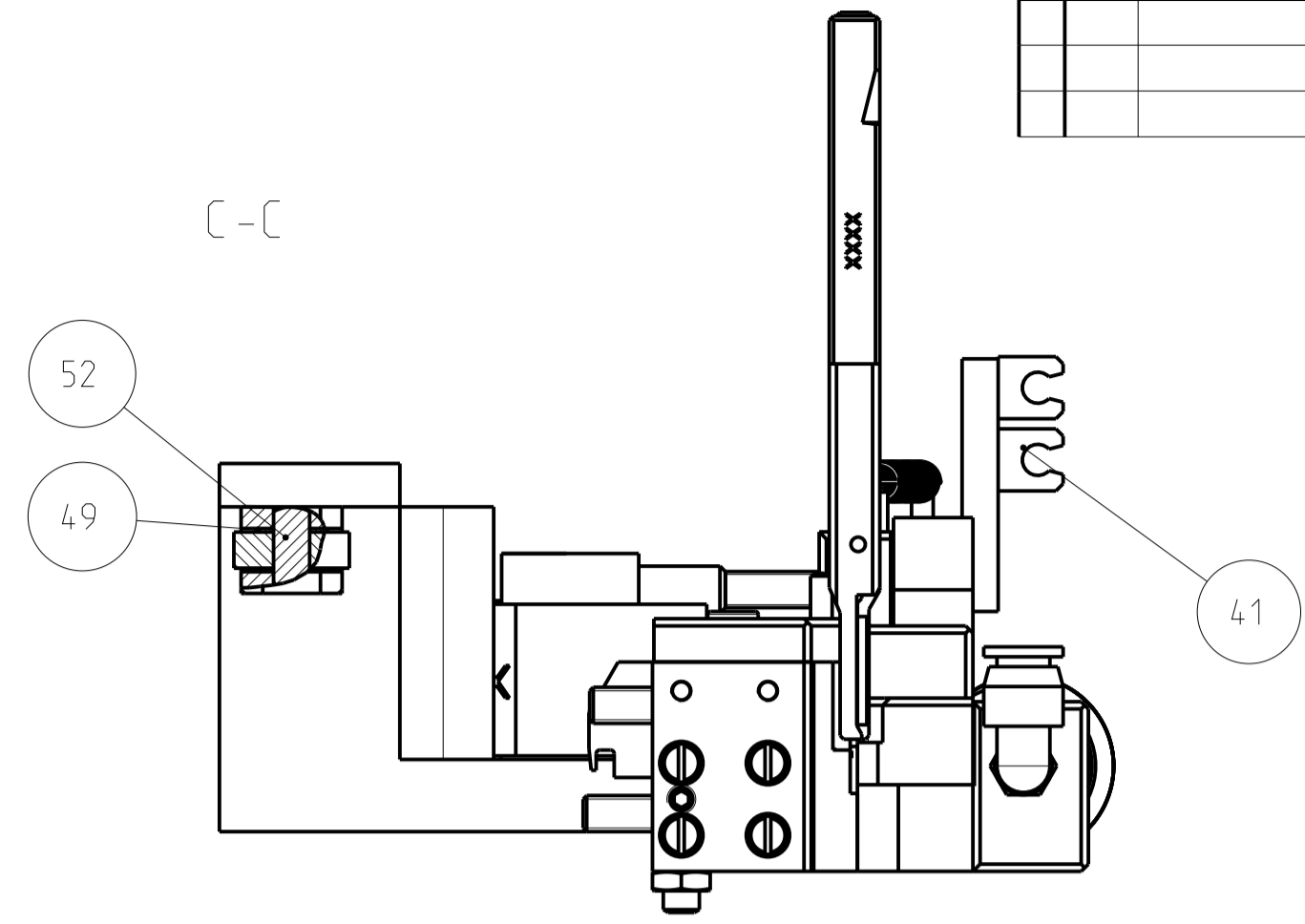
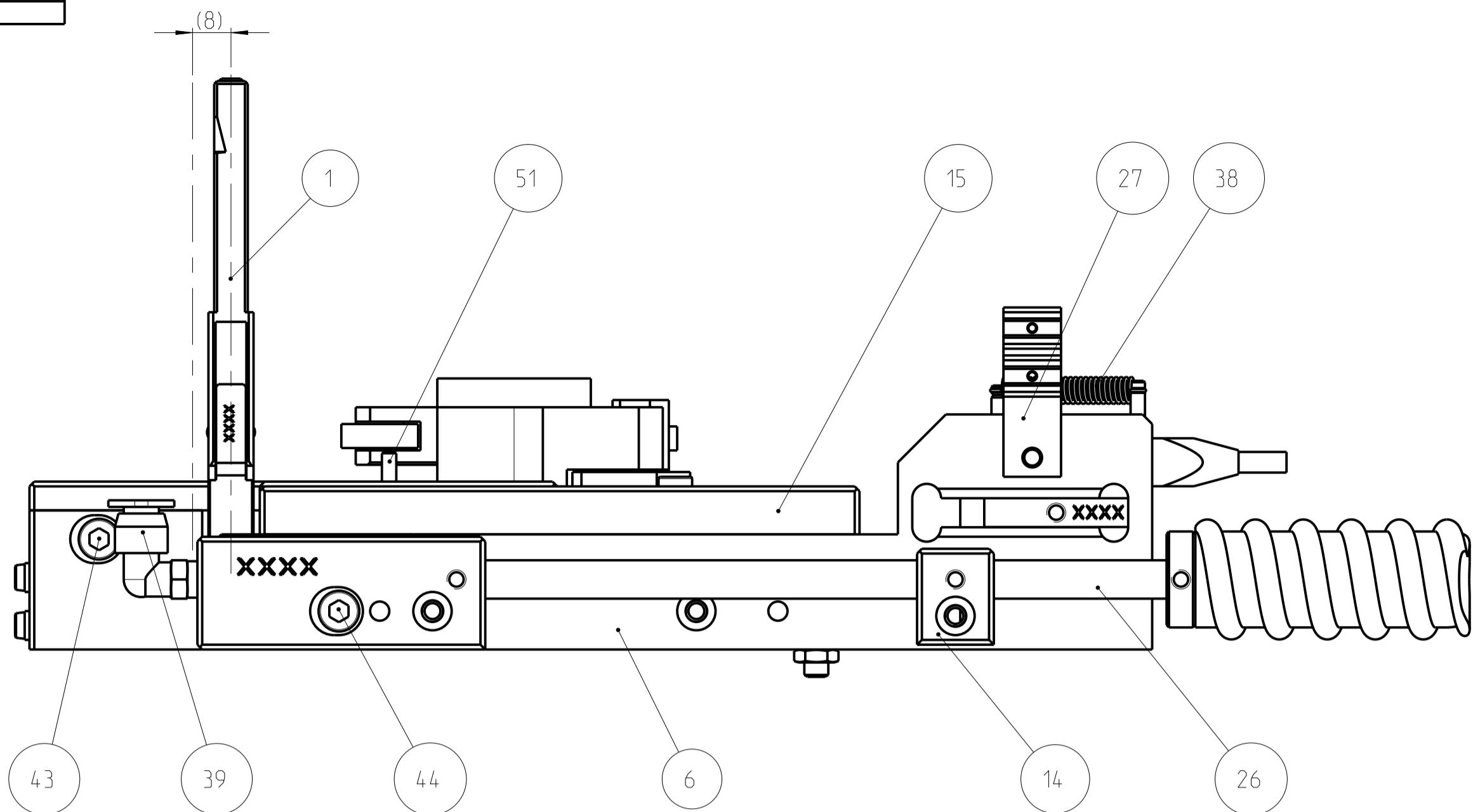
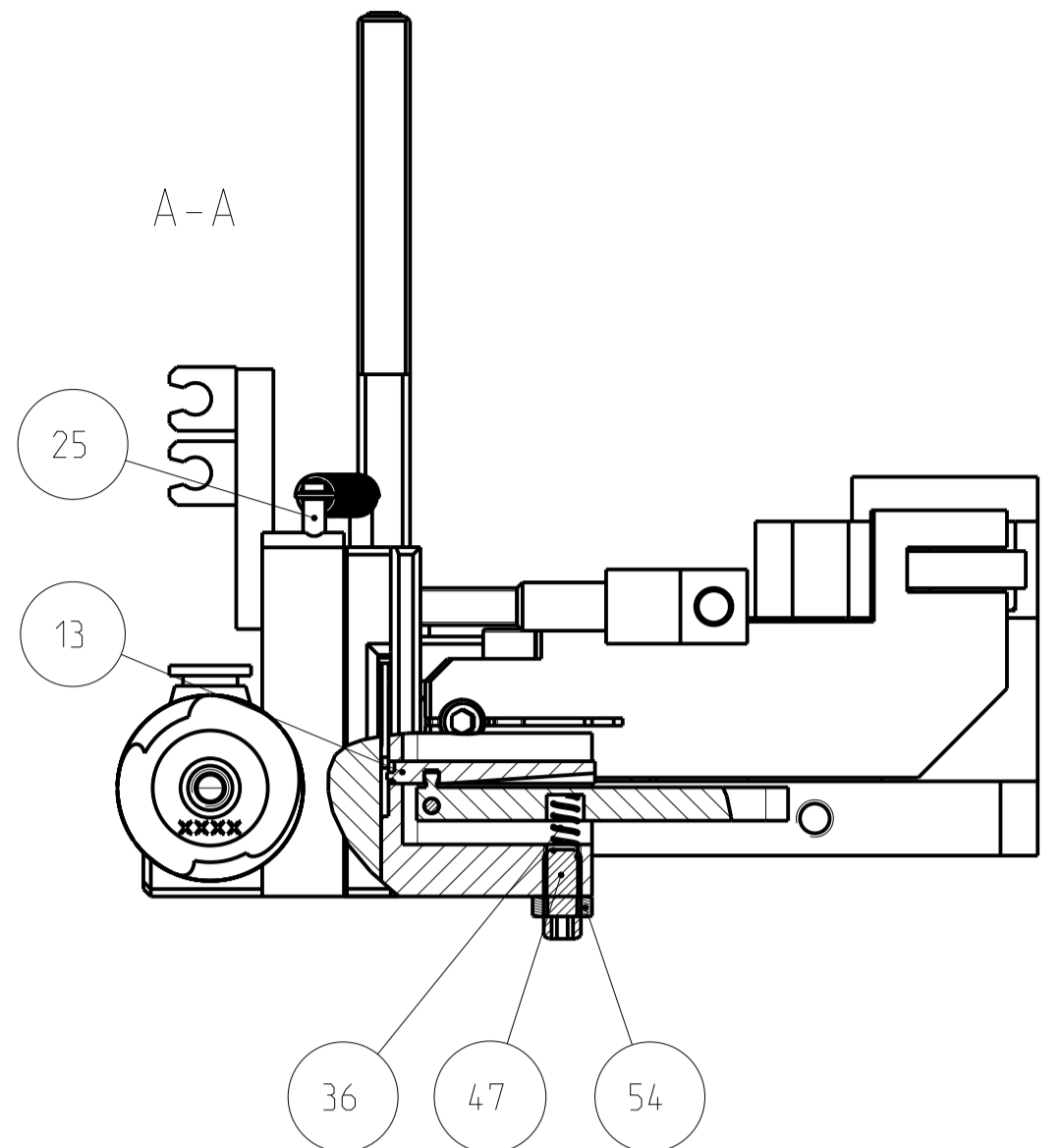

FUER DOPPELSTIFT BASISWERKZEUG  
 FOR DOUBLE PIN INSERTION HEAD

bei Montage abgestimmt  
 adjusted while mounting

EINZELSTIFTVERARBEITUNG MITTIG GEDREHT  
 SINGLE PIN PRODUCTION CENTER TURNED

PRODUCT: TAB 6.3x0.8

THIS DRAWING IS A CONTROLLED DOCUMENT.		DMN RIKON-Riedel	06APR2011	TE Connectivity	
DIMENSIONS:		CHK		NAME	
mm		APVD		UMBAUSATZ CONVERSION KIT	
TOLERANCES UNLESS OTHERWISE SPECIFIED: 0 PLC # # # # # 1 PLC # # # # # 2 PLC # # # # # 3 PLC # # # # # 4 PLC # # # # # ANGLES # # # # #		PRODUCT SPEC		RESTRICTED TO	
MATERIAL		FINISH	WEIGHT	SIZE	CAGE CODE DRAWING NO
				A1	00779 ©=5-1372410-4
			CUSTOMER DRAWING	SCALE	SHEET 1 OF 3 REV B

THIS DRAWING IS UNPUBLISHED. RELEASED FOR PUBLICATION 2012  
 © COPYRIGHT 2012 BY Tyco Electronics AMP GmbH ALL RIGHTS RESERVED.

REVISIONS				
NO.	DATE	DESCRIPTION	BY	APPV
-	-	SEE SHEET 1	-	-

POS	QTY	TE/PN	PART REV	DESCRIPTION	WEAR	SPARE
1	1	4-1372415-1	B	Setzfinger komplett insertion finger complete	YES	YES
2	1	2-1372477-0	A	SCHNITTPLATTE cutting plate	YES	YES
3	1	1-1372477-1	A	SCHNITTMESSER cutting blade	YES	YES
4	1	9-539939-3	B	VORSCHUBFINGER FEEDING FINGER	YES	YES
5	1	2-1372477-1	A	WERKZEUGBASIS tool base	-	-
6	1	2-1372477-2	B	FUEHRUNG VORNE guiding front	-	-
7	1	4-1372421-2	B	HALTER holder	-	-
8	1	4-1372421-3	B	HEBEL lever	-	-
9	1	7-1372335-9	B	STOESSEL ram	-	-
10	1	2-1372386-7	C	ABSAUGKLOTZ sucking block	-	-
11	1	5-1372234-5	B	Spliceerkennung innen recognition inside	-	-
12	1	5-1372234-6	B	Spliceerkennung aussen recognition outside	-	-
13	1	2-1372269-9	C	BREMSE brake	-	-
14	1	5-1372234-8	B	Halter holder	-	-
15	1	2-1372477-3	A	NIEDERHALTER downholder	-	-
16	1	6-1372234-0	C	Adapter adapter	-	-
17	1	2-1372481-2	A	ABSTIMMKLOTZ ADJUSTING BLOCK	-	-
18	1	6-1372234-3	B	Achse axis	-	-
19	1	2-1372477-4	A	TRANSPORTSCHIEBER transport slider	-	-
20	1	7-1372386-5	B	DECKEL cover	-	-
21	1	1-1372347-4	B	DECKEL cover	-	-
22	1	7-1372328-5	B	FEDERBOLZEN spring bolt	-	-
23	1	3-1372269-2	B	HEBEL lever	-	-
24	1	6-539939-7	B	BOLZEN BOLT	-	-
25	2	2-1372209-1	B	STIFT pin	-	-
26	1	2-1372209-2	B	ABSAUGROHR suction tube	-	-
27	1	4-1372234-1	B	Halter holder	-	-
28	1	3-656688-5	B	FUEHRUNGSBUCHSE GUIDE BUSHING	-	YES
29	1	3-656688-7	B	KUGELKAEFIG BALL BEARING CAGE	-	YES
30	2	516403-1	A	FLOW ROLLER LAUFROLL	-	YES
31	1	511591-8	A	KUGELDRUCKSCHRAUBE M6*16 -	-	YES
32	1	4-523159-7	A	Initiator sensor	-	YES
33	1	506797-1	A	BOLT NORELEM: 02010-061	-	YES
34	1	2030564-1	A	CABLE, CONNECTING, METAL COUPLING, ANGLE -	-	YES
35	1	6-510500-5	A	Druckfeder PRESSURE SPRING	-	YES
36	1	8-653861-4	E	DRUCKFEDER PRESSURE SPRING	-	YES
37	1	1372409-1	A	Druckfeder COMPRESSION SPRING	-	YES
38	1	9-653860-9	A	Zugfeder TENSION SPRING	-	YES
39	1	993083-4	A1	CONNECTOR, ELBOW, 90°, MINI -	-	YES
40	1	1372292-2	B	ABSAUGSCHLAUCH PLASTIC TUBE	-	YES
41	2	510974-1	A	CLAMP SCHLAUCHKLEMMEN	-	YES

42	1	2-519000-3	A	Zylinderschr. M4x16 DIN 912 -	-	YES
43	1	3-519000-4_GATD_DKB	A	Zylinderschr. M5x25 DIN 912 -	-	-
44	1	519072-9_GATD_DKB	A	Zylinderschr. M5x65 DIN 912 -	-	-
45	4	2-519003-1_GATD_DKB	A	Zylinderschr. M3x5 DIN 84 -	-	-
46	2	3-519011-0_GATD_DKB	A	Gewindestift M4x8 DIN 913 -	-	-
47	1	3-519011-9_GATD_DKB	A	Gewindestift M5x12 DIN 913 -	-	-
48	4	519115-1_GATD_DKB	A	Passscheibe 3x6x1 DIN 988 -	-	-
49	4	519037-3	A	Passscheibe 5x10x0.5 DIN 988 -	-	YES
50	2	1-519115-0	A	Passscheibe 12x18x1 DIN 988 -	-	YES
51	1	3-519051-7	A	Zyl.-Stift 3m6x24 DIN 6325 -	-	YES
52	1	6-519051-3	A	Zyl.-Stift 5m6x12 DIN 6325 -	-	YES
53	1	6-519051-7	A	Zyl.-Stift 5m6x20 DIN 6325 -	-	YES
54	1	519019-6	A	Mutter M5 DIN 934 Hexagonal Nut M5 DIN 934	-	YES

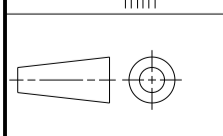
THIS DRAWING IS A CONTROLLED DOCUMENT.		OWN: RIKON-Riedel	06APR2011		
DIMENSIONS: mm		CHK: -	APVD: -		
		TOLERANCES UNLESS OTHERWISE SPECIFIED: 0 PLC ± 1 PLC ± 2 PLC ± 3 PLC ± 4 PLC ± ANGLES ±		NAME: UMBBAUSATZ CONVERSION KIT PRODUCT SPEC: - APPLICATION SPEC: -	
MATERIAL: -		FINISH: -		SIZE: A1 CAGE CODE: 00779 DRAWING NO: ©=5-1372410-4 RESTRICTED TO: -	
CUSTOMER DRAWING		SCALE: 1:1		SHEET 2 OF 3 REV B	

REVISIONS					
P.	LTN	DESCRIPTION	DATE	DWN	APVD
-	-	SEE SHEET 1	-	-	-

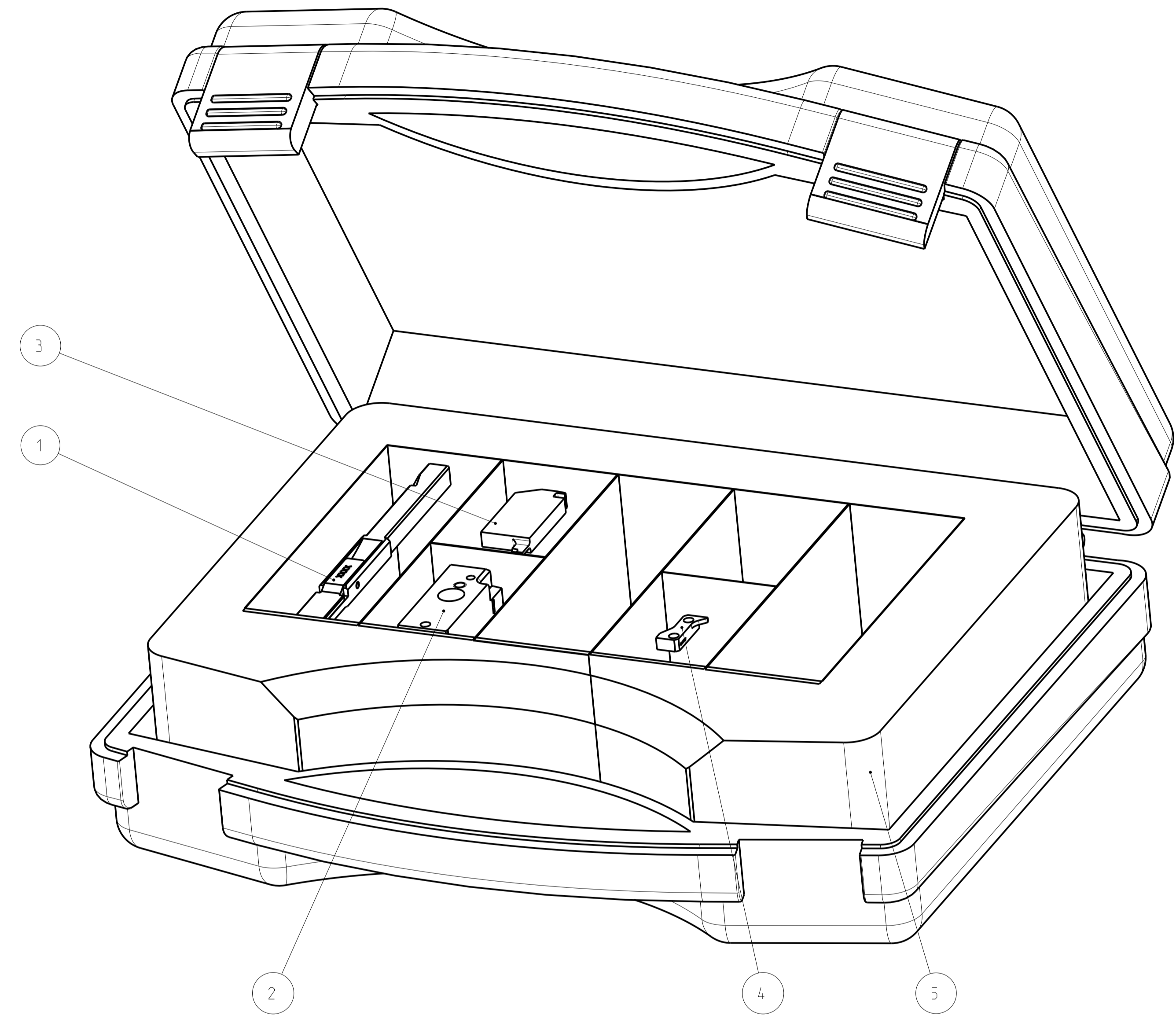

TOOL KIT 5-1372400-4  
 SHOWN

POS	QTY	TE/PN	PART REV	DESCRIPTION	WEAR	SPARE
1	1	4-1372415-1	B	Setzfinger komplett insertion finger complete	YES	YES
2	1	2-1372477-0	A	SCHNITTPLATTE cutting plate	YES	YES
3	1	1-1372477-1	A	SCHNITTMESSER cutting blade	YES	YES
4	1	9-539939-3	B	VORSCHUBFINGER FEEDING FINGER	YES	YES
5	1	539383-5	B	SUIT CASE ERSATZTEILKOFFER	-	-

THIS DRAWING IS A CONTROLLED DOCUMENT. DWN: RIKON-Riedel 06APR2011  
 DIMENSIONS: mm TOLERANCES UNLESS OTHERWISE SPECIFIED: 0 PLC ±0.1, 1 PLC ±0.1, 2 PLC ±0.1, 3 PLC ±0.1, 4 PLC ±0.1, ANGLES ±0.1  
 MATERIAL: - FINISH: -  
 CUSTOMER DRAWING

**STE** TE Connectivity  
 NAME: UMBBAUSATZ CONVERSION KIT  
 PRODUCT SPEC: -  
 APPLICATION SPEC: -  
 SIZE: A1 CAGE CODE: 00779 DRAWING NO: 5-1372410-4 RESTRICTED TO: -  
 WEIGHT: - SCALE: 1:1 SHEET 3 OF 3 REV B