



A Product Line of
Diodes Incorporated



SPECIFICATION FOR APPROVAL

CUSTOMER	_____
NOMINAL FREQUENCY	25.000000 MHz
PRODUCT TYPE	TYPE F8 8.0x4.5 GLASS SEALED CRYSTAL
SPEC. NO. (P/N)	F82500071
CUSTOMER P/N	_____
ISSUE DATE	January 5, 2018
VERSION	C

APPROVED	PREPARED	QA

Diodes Incorporated

No.2, Ziqiang 5th Rd., Zhongli Industrial Park,
 Zhongli Dist., Taoyuan City 32063, Taiwan (R.O.C.)
 TEL: 886-3-451-8888
 FAX: 886-3-461-3865
<https://www.diodes.com>

*RoHS Exemption
 *HF-Halogen Free
 *REACH Compliant

TYPE F8 8.0x4.5 GLASS SEALED CRYSTAL

F82500071

VER. C 5-Jan-18

ELECTRICAL SPECIFICATIONS

Item	Symbol	Specifications	Units	Notes
Nominal Frequency	Fn	25.000000	MHz	
Mode of Oscillation	MO	AT Cut-Fundamental		
Calibration Load Capacitance	CL	16	pF	
Calibration Tolerance	FL	±50	ppm	at 25°C±3°C
Operating Temperature Range	TR	-20 to +70	°C	
Frequency Stability (Frequency Deviation over the Operating Temperature Range)	F/T	±50	ppm	Reference to the Frequency at 25°C
Operating Drive Level		10	μW	
Maximum Drive Level		100	μW	
Equivalent Series Resistance	ESR	50	Ω	Max
Shunt Capacitance	C0	5	pF	Max.
Aging at 25°C		±5	ppm	Max, 1st year
Storage Temperature		-55 to +125	°C	
Insulation Resistance		500	MΩ	Min

TYPE F8 8.0x4.5 GLASS SEALED CRYSTAL

F82500071

VER. C 5-Jan-18

RELIABILITY SPECIFICATIONS

MECHANICAL AND ENVIRONMENTAL RATINGS:

- a) FINE LEAK TEST: JESD22-A109 (Condition 1A)
- b) GROSS LEAK TEST: JESD22-A109 (Condition C)
- c) MOISTURE RESISTANCE: JESD22-A113
- d) SHOCK: JESD22-B104 (Condition B)
- e) SOLDERABILITY : (RoHS version): J-STD-002
- f) VIBRATION: JESD22-B103
- g) SOLVENT RESISTANCE: JESD22-B107
- h) RESISTANCE TO SOLDERING HEAT (RoHS version): J-STD-020D Table 5.2 Pb free devices (3 cycles max)

SUGGESTED IR REFLOW PROFILE

*As per IPC-JEDEC J-STD-020D

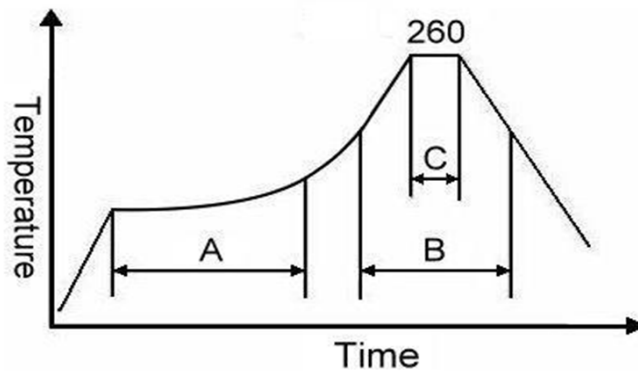

Note:

	Stage	Temperature	Time
A	Preheat	150~200°C	60~120 Sec
B	Primary Heat	217°C	60~150 Sec
C	Peak	260°C	10 Sec

TYPE F8 8.0x4.5 GLASS SEALED CRYSTAL

F82500071

VER. C 5-Jan-18

MARKING

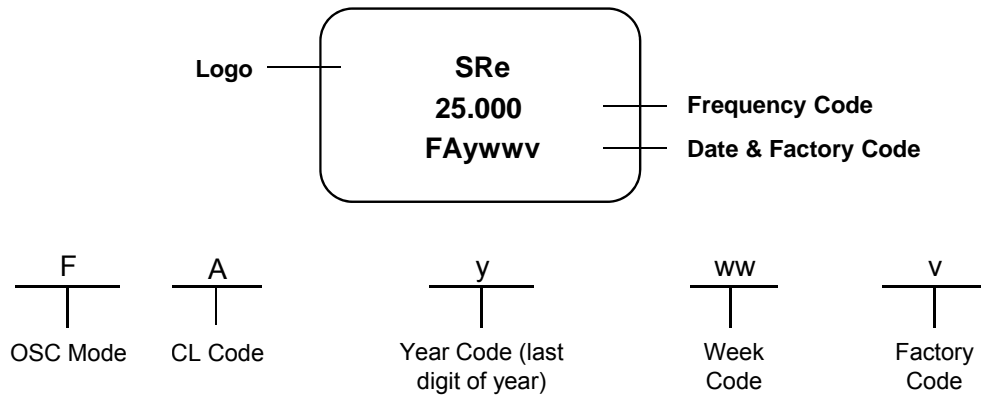

MECHANICAL DRAWINGS (Scale: None. Dimensions are in mm.)

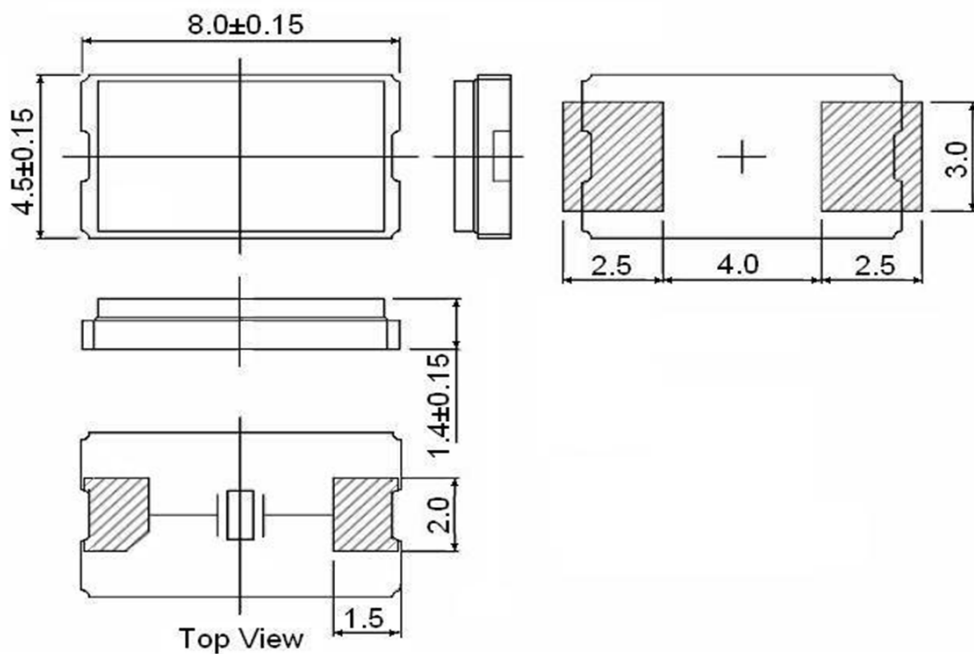

TYPE F8 8.0x4.5 GLASS SEALED CRYSTAL

F82500071

VER. C 5-Jan-18

Tape & Reel

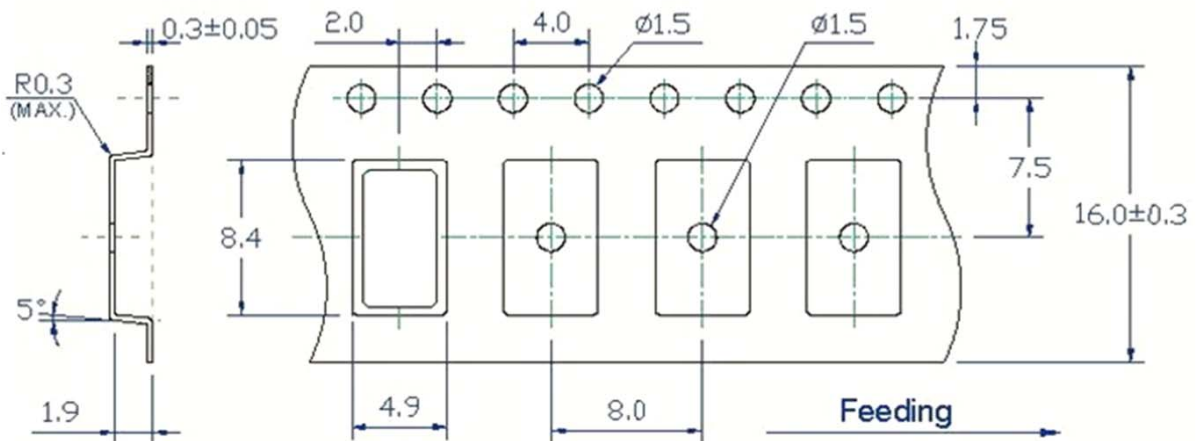

1. 230mm minimum leafer which consist of carrier and/or tape followed by a minimum of 160mm of empty carrier tape sealed with cover tape.
2. 160mm minimum trailer of empty carrier tape sealed with cover tape.

TYPE F8 8.0x4.5 GLASS SEALED CRYSTAL

F82500071

VER. C 5-Jan-18

PACKING

