

THIS DRAWING IS UNPUBLISHED. RELEASED FOR PUBLICATION
 © COPYRIGHT - By - ALL RIGHTS RESERVED.

LOC	DIST	REVISIONS			
P	LTR	DESCRIPTION	DATE	DWN	APVD
AF	50	G2	ECR-15-005665	10AUG2015	BDA/ PK

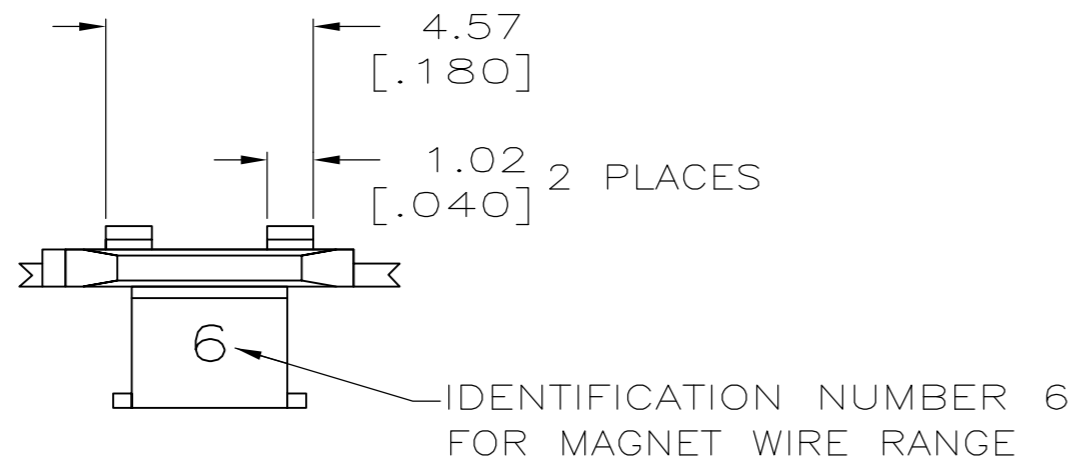

- 1 CONTINUOUS STRIP ON REELS WITH TERMINALS LOCATED ON 8.38±0.08 [.330±.003] CENTERS.
- 2 SLOT ACCEPTS 0.25-0.36mm [#30-#27] AWG COPPER MAGNET WIRE.
 SLOT ACCEPTS 0.32-0.45mm [#28-#25] AWG ALUMINUM MAGNET WIRE.
 ALUMINUM WIRE RANGE APPLIES FOR POST-TIN PLATED VERSIONS ONLY.
 2 WIRES OF THE SAME SIZE MAX PER SLOT.
- 3 0.002032[.000080] MIN TIN PER MIL-T-10727.

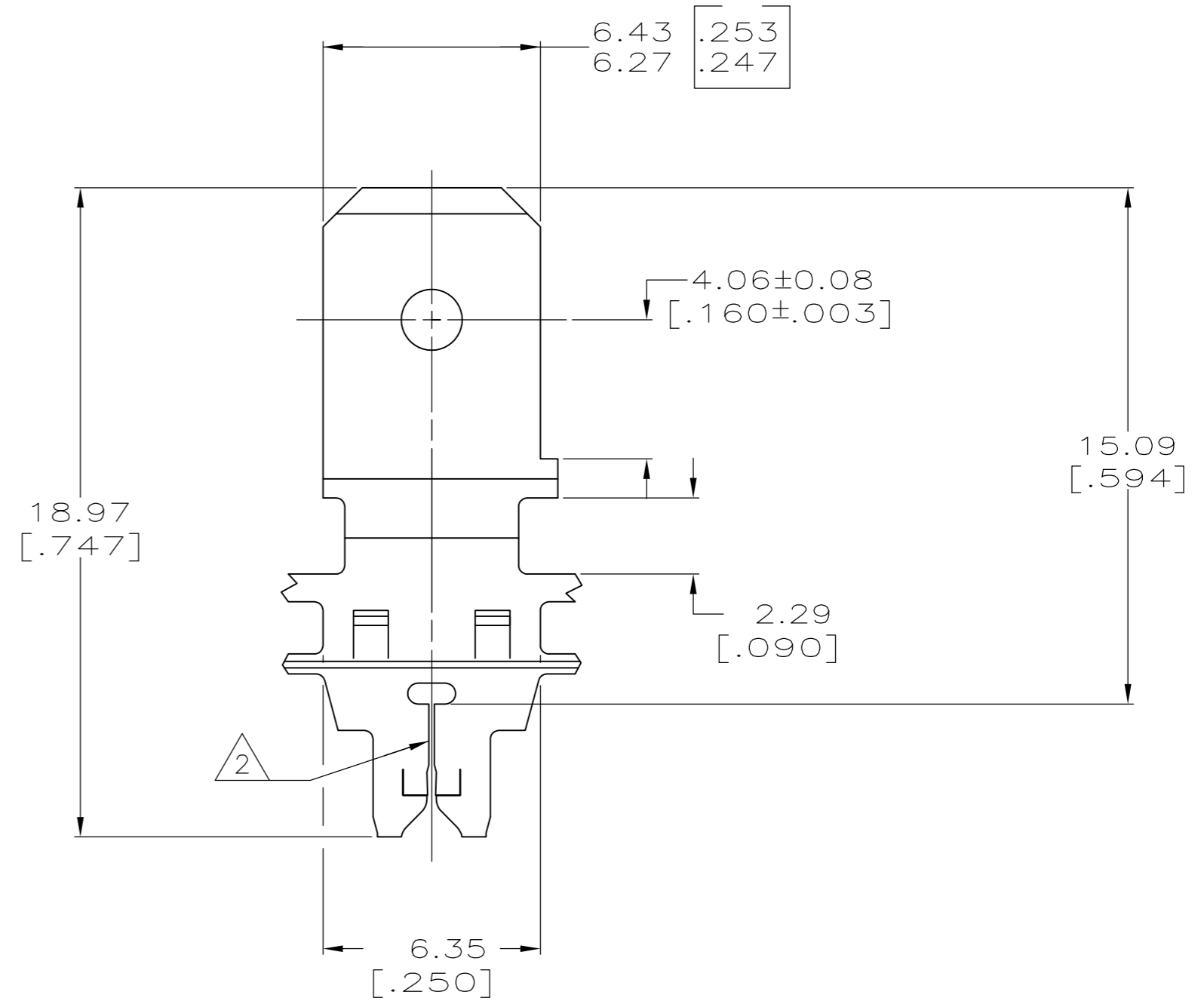
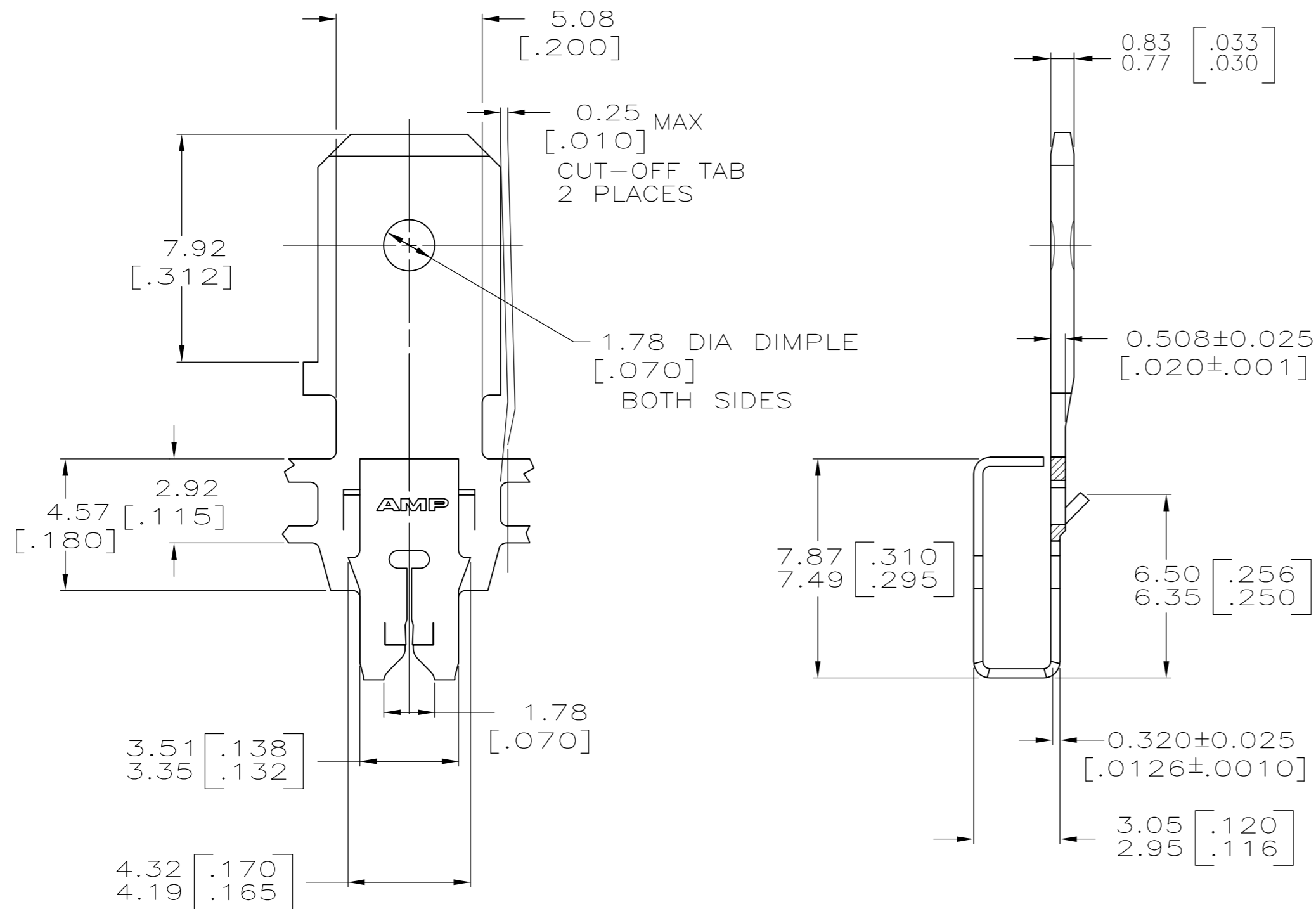

MATERIAL	FINISH	PART NUMBER
082 BRASS	3	63132-3
4M BRASS	NONE	63132-2
4M BRASS	3	63132-1

THIS DRAWING IS A CONTROLLED DOCUMENT.		DWN MICHAEL S. FEHER 07FEB97	TE TE Connectivity		
DIMENSIONS: mm [INCHES]		CHK RICHARD GRZYBOWSKI 10FEB97			
TOLERANCES UNLESS OTHERWISE SPECIFIED:		APVD NELSON E. NEFF 10FEB97	NAME TAB, 6.35[.250] FASTON™ MAG-MATE™		
0 PLC ± - 1 PLC ± - 2 PLC ± 0.25[.010] 3 PLC ± - 4 PLC ± - ANGLES ± 1°		PRODUCT SPEC 108-2012	SIZE A2	CAGE CODE 00779	DRAWING NO 63132
MATERIAL SEE TABLE		FINISH SEE TABLE	WEIGHT -	RESTRICTED TO -	SCALE 6:1
CUSTOMER DRAWING			SHEET 1 of 1	REV G2	