

DIN rail mounting frame - HC-CIF-B16-HFWL-PL - 1424336

Please be informed that the data shown in this PDF Document is generated from our Online Catalog. Please find the complete data in the user's documentation. Our General Terms of Use for Downloads are valid (<http://phoenixcontact.com/download>)



HEAVYCON DIN rail mounting frame, for type B16 contact inserts



COMPLIANT

Key Commercial Data

Packing unit	1 pc
GTIN	 4 055626 370743
GTIN	4055626370743

Technical data

Dimensions

Length	144 mm
Width	42 mm
Height	61 mm

Ambient conditions

Ambient temperature (operation)	-40 °C ... 125 °C
---------------------------------	-------------------

General

Size	B16
Material	PC
Flammability rating according to UL 94	V0
Color	traffic grey
Note	for B16, BB32, DD72, HS6, HV6 contact inserts and B16 module frame

Standards and Regulations

Flammability rating according to UL 94	V0
--	----

Environmental Product Compliance

	Lead 7439-92-1
China RoHS	Environmentally Friendly Use Period = 50

DIN rail mounting frame - HC-CIF-B16-HFWL-PL - 1424336

Technical data

Environmental Product Compliance

	For details about hazardous substances go to tab "Downloads", Category "Manufacturer's declaration"
--	---

Drawings

Dimensional drawing

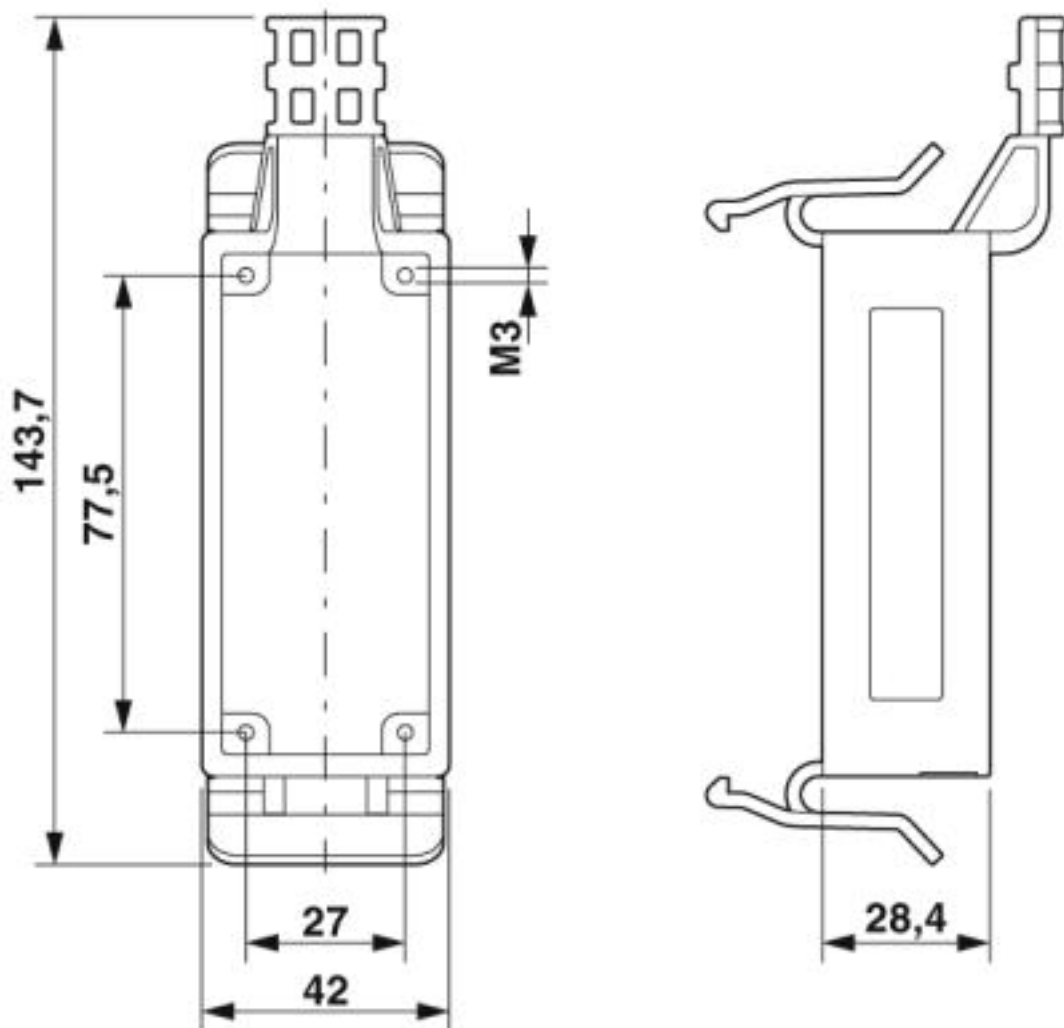

Dimensional drawing

Approvals

Approvals

DIN rail mounting frame - HC-CIF-B16-HFWL-PL - 1424336

Approvals

Approvals

EAC / UL Recognized / cUL Recognized / cULus Recognized

Ex Approvals

Approval details

EAC		EAC-Zulassung	
UL Recognized		http://database.ul.com/cgi-bin/XYV/template/LISEXT/1FRAME/index.htm	E118976
cUL Recognized		http://database.ul.com/cgi-bin/XYV/template/LISEXT/1FRAME/index.htm	E118976
cULus Recognized			

Phoenix Contact 2019 © - all rights reserved
<http://www.phoenixcontact.com>

PHOENIX CONTACT GmbH & Co. KG
Flachsmarktstr. 8
32825 Blomberg
Germany
Tel. +49 5235 300
Fax +49 5235 3 41200
<http://www.phoenixcontact.com>