

| MATERIAL NO. | ENGINEERING NO. | FINISHED LENGTH |
|--------------|-----------------|-----------------------------------|
| 1300068143 | 105007B21M050 | 16'5" +6.50"-0 (5M +165.1mm-0) |
| 1300068144 | 105007B21M100 | 32'10" +12.50"-0 (10M +317.5mm-0) |
| 1300068145 | 105007B21M200 | 65'7" +24.50"-0 (20M +622.3mm-0) |
| 1300068146 | 105007B21M300 | 98'5" +24.50"-0 (30M +622.3mm-0) |

NOTES:

- MATERIAL: SEE TABLE
- FINISHES: SEE TABLE
- ELECTRICAL SPECIFICATIONS
VOLTAGE RATING: 300V AC/DC
CURRENT RATING: 8 AMPS
- PROTECTION: IP67
- ASSEMBLY IS RoHS COMPLIANT BY EXEMPTION

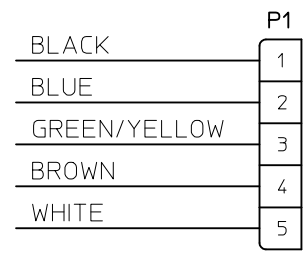
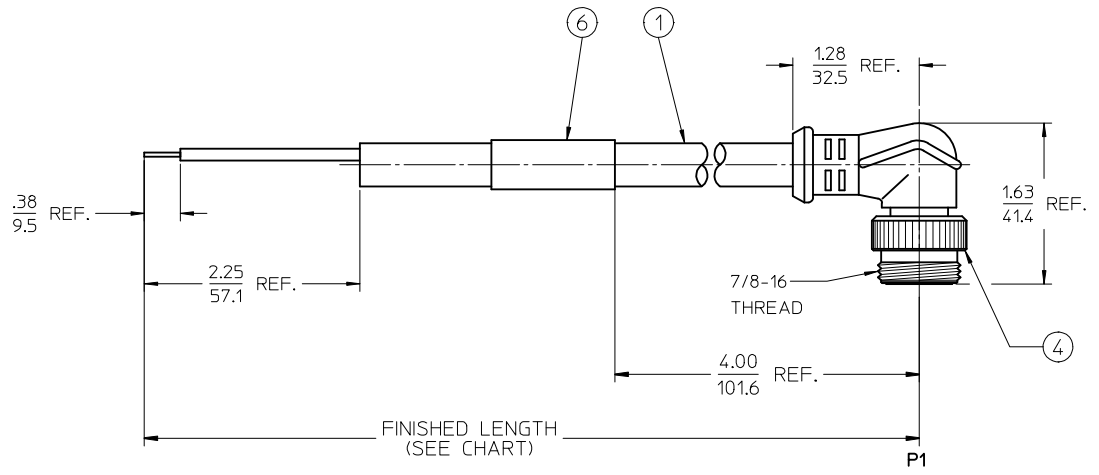

WIRING DIAGRAM

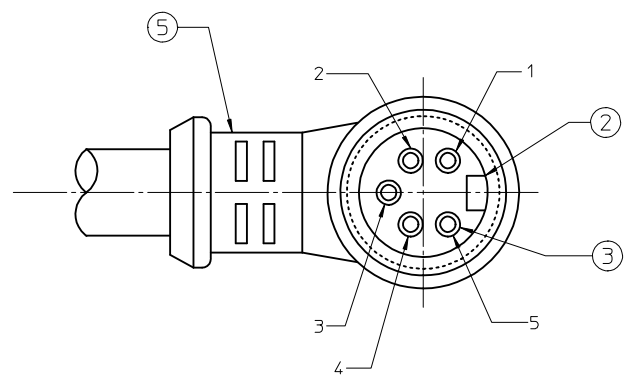

MALE FACE VIEW
SCALE: 2X

| 6 | 1 | WRAP LABEL | MYLAR | BLACK/YELLOW |
|------|------|--|---------------|--------------|
| 5 | 2 | OVERMOLD-90 DEG | PUR | BLACK |
| 4 | 1 | COUPLING RING-EXT. THREAD | ZINC DIE-CAST | BLACK |
| 3 | 5 | CONTACT PIN | Cu ALLOY | GOLD PLATED |
| 2 | 1 | INSERT, 5P-MALE | PUR | BLACK |
| 1 | A/R | CABLE 5/C, 1.5mm ² (16 AWG) | PUR JACKET | GRAY |
| ITEM | QTY. | DESCRIPTION | MATERIAL | FINISH |

| RELEASED EC NO: DRWINRSTONE 2012/11/12 CHKDK JOZWIK 2012/11/26 APPR: | DESCRIPTION REV: | QUALITY SYMBOLS ▽=0 ▽=0 | GENERAL TOLERANCES (UNLESS SPECIFIED) <table border="1"> <thead> <tr> <th></th> <th>mm</th> <th>INCH</th> </tr> </thead> <tbody> <tr> <td>4 PLACES</td> <td>± ---</td> <td>± ---</td> </tr> <tr> <td>3 PLACES</td> <td>± ---</td> <td>± ---</td> </tr> <tr> <td>2 PLACES</td> <td>± ---</td> <td>± .01</td> </tr> <tr> <td>1 PLACE</td> <td>± 0.3</td> <td>± ---</td> </tr> <tr> <td>0 PLACE</td> <td>± ---</td> <td>± ---</td> </tr> </tbody> </table> | | mm | INCH | 4 PLACES | ± --- | ± --- | 3 PLACES | ± --- | ± --- | 2 PLACES | ± --- | ± .01 | 1 PLACE | ± 0.3 | ± --- | 0 PLACE | ± --- | ± --- | DIMENSION STYLE IN/MM | SCALE 1:1 | DESIGN UNITS INCH | THIRD ANGLE PROJECTION |
|---|---------------------|-------------------------------|--|---|----------------------------|------|----------|-------|-------|----------|-------|-------|----------|-------|-------|---------|-------|-------|---------|-------|-------|---------------------------------|---------------------|-----------------------------|------------------------|
| | | mm | INCH | | | | | | | | | | | | | | | | | | | | | | |
| | 4 PLACES | ± --- | ± --- | | | | | | | | | | | | | | | | | | | | | | |
| | 3 PLACES | ± --- | ± --- | | | | | | | | | | | | | | | | | | | | | | |
| 2 PLACES | ± --- | ± .01 | | | | | | | | | | | | | | | | | | | | | | | |
| 1 PLACE | ± 0.3 | ± --- | | | | | | | | | | | | | | | | | | | | | | | |
| 0 PLACE | ± --- | ± --- | | | | | | | | | | | | | | | | | | | | | | | |
| DRAFT WHERE APPLICABLE MUST REMAIN WITHIN DIMENSIONS | | | DRAWN BY: RSTONE DATE: 2012/11/12 CHECKED BY: K JOZWIK DATE: 2012/11/26 APPROVED BY: DATE: | TITLE MINI CHANGE CABLE ASSY. 5P MP, 90 DEGREE 1.5MM² (16 AWG) PUR | | | | | | | | | | | | | | | | | | | | | |
| MATERIAL NO. SEE CHART | | | DOCUMENT NO. SD-130006-046 | | SHEET NO. 1 OF 1 | | | | | | | | | | | | | | | | | | | | |
| THIS DRAWING CONTAINS INFORMATION THAT IS PROPRIETARY TO MOLEX INCORPORATED AND SHOULD NOT BE USED WITHOUT WRITTEN PERMISSION | | | | | | | | | | | | | | | | | | | | | | | | | |

| MATERIAL NO. | ENGINEERING NO. | FINISHED LENGTH |
|--------------|-----------------|-----------------------------------|
| 1300068143 | 105007B21M050 | 16'5" +6.50"-0 (5M +165.1mm-0) |
| 1300068144 | 105007B21M100 | 32'10" +12.50"-0 (10M +317.5mm-0) |
| 1300068145 | 105007B21M200 | 65'7" +24.50"-0 (20M +622.3mm-0) |
| 1300068146 | 105007B21M300 | 98'5" +24.50"-0 (30M +622.3mm-0) |

NOTES:

1. MATERIAL: SEE TABLE
2. FINISHES: SEE TABLE
3. ELECTRICAL SPECIFICATIONS
VOLTAGE RATING: 300V AC/DC
CURRENT RATING: 8 AMPS
4. PROTECTION: IP67
5. ASSEMBLY IS RoHS COMPLIANT BY EXEMPTION

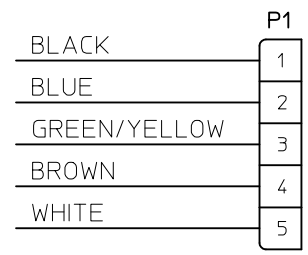
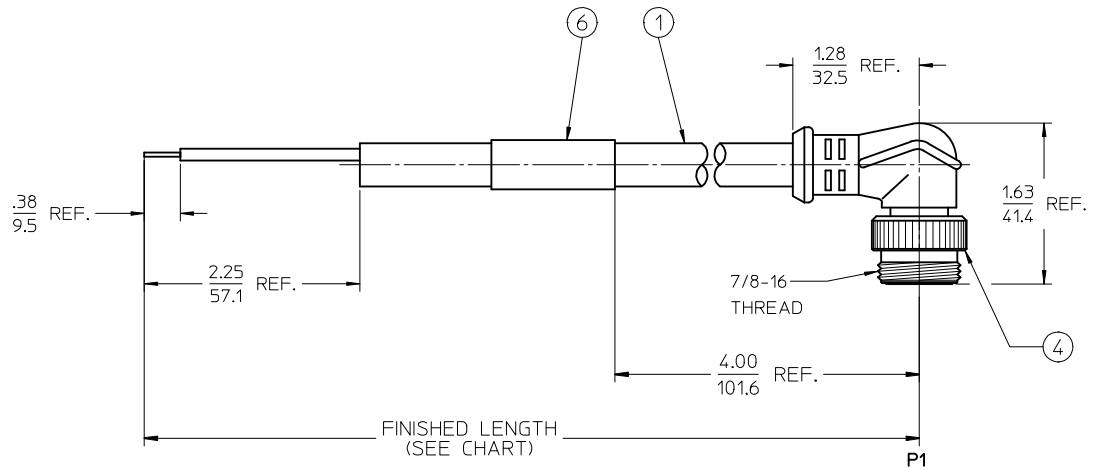

WIRING DIAGRAM

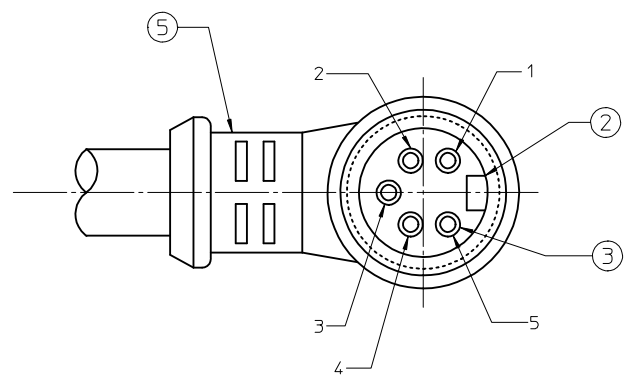

MALE FACE VIEW
SCALE: 2X

| 6 | 1 | WRAP LABEL | MYLAR | BLACK/YELLOW |
|------|------|--|---------------|--------------|
| 5 | 2 | OVERMOLD-90 DEG | PUR | BLACK |
| 4 | 1 | COUPLING RING-EXT. THREAD | ZINC DIE-CAST | BLACK |
| 3 | 5 | CONTACT PIN | Cu ALLOY | GOLD PLATED |
| 2 | 1 | INSERT, 5P-MALE | PUR | BLACK |
| 1 | A/R | CABLE 5/C, 1.5mm ² (16 AWG) | PUR JACKET | GRAY |
| ITEM | QTY. | DESCRIPTION | MATERIAL | FINISH |

| RELEASED EC NO: DRWINRSTONE 2012/11/12 CHKDK JOZWIK 2012/11/26 APPR: | DESCRIPTION QUALITY SYMBOLS ▽=0 ▽=0 | GENERAL TOLERANCES (UNLESS SPECIFIED) | | DIMENSION STYLE IN/MM | SCALE 1:1 | DESIGN UNITS INCH | THIRD ANGLE PROJECTION | | | | | | | | | | | | | | | | | | | |
|---|--|---|--------------------|----------------------------------|-------------------------------|----------------------|------------------------|-------|-------|----------|-------|-------|----------|-------|-------|---------|-------|-------|---------|-------|-------|--------------------|--------------------|--|--|--|
| | | <table border="1"> <thead> <tr> <th></th> <th>mm</th> <th>INCH</th> </tr> </thead> <tbody> <tr> <td>4 PLACES</td> <td>± ---</td> <td>± ---</td> </tr> <tr> <td>3 PLACES</td> <td>± ---</td> <td>± ---</td> </tr> <tr> <td>2 PLACES</td> <td>± ---</td> <td>± .01</td> </tr> <tr> <td>1 PLACE</td> <td>± 0.3</td> <td>± ---</td> </tr> <tr> <td>0 PLACE</td> <td>± ---</td> <td>± ---</td> </tr> </tbody> </table> | | | mm | INCH | 4 PLACES | ± --- | ± --- | 3 PLACES | ± --- | ± --- | 2 PLACES | ± --- | ± .01 | 1 PLACE | ± 0.3 | ± --- | 0 PLACE | ± --- | ± --- | DRAWN BY RSTONE | DATE 2012/11/12 | TITLE MINI CHANGE CABLE ASSY. 5P MP, 90 DEGREE 1.5MM ² (16 AWG) PUR molex | | |
| | | | mm | INCH | | | | | | | | | | | | | | | | | | | | | | |
| | | 4 PLACES | ± --- | ± --- | | | | | | | | | | | | | | | | | | | | | | |
| 3 PLACES | ± --- | ± --- | | | | | | | | | | | | | | | | | | | | | | | | |
| 2 PLACES | ± --- | ± .01 | | | | | | | | | | | | | | | | | | | | | | | | |
| 1 PLACE | ± 0.3 | ± --- | | | | | | | | | | | | | | | | | | | | | | | | |
| 0 PLACE | ± --- | ± --- | | | | | | | | | | | | | | | | | | | | | | | | |
| ANGULAR ± 2 ° DRAFT WHERE APPLICABLE MUST REMAIN WITHIN DIMENSIONS | | CHECKED BY K JOZWIK | DATE 2012/11/26 | MATERIAL NO. SEE CHART | DOCUMENT NO. SD-130006-046 | SHEET NO. 1 OF 1 | | | | | | | | | | | | | | | | | | | | |
| THIS DRAWING CONTAINS INFORMATION THAT IS PROPRIETARY TO MOLEX INCORPORATED AND SHOULD NOT BE USED WITHOUT WRITTEN PERMISSION | | | | | | | | | | | | | | | | | | | | | | | | | | |