

| DATE    | REV | ECN   | APP'D. BY |
|---------|-----|-------|-----------|
| 1-5-15  | A2  | 10167 | TRM       |
| 3-14-16 | A3  | 10606 | TRM       |
|         |     |       |           |
|         |     |       |           |

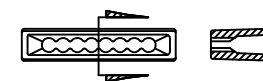

MANAGEMENT BAR TO BE USED WITH PLUG

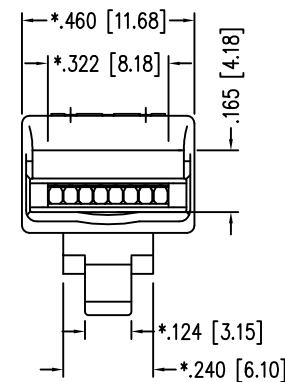
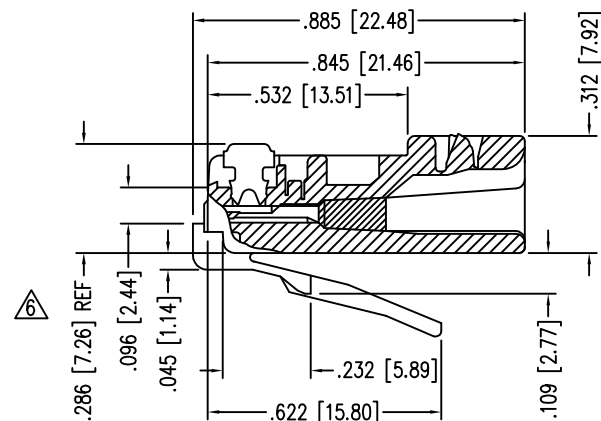
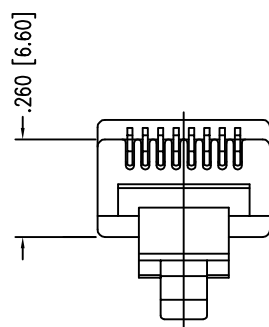
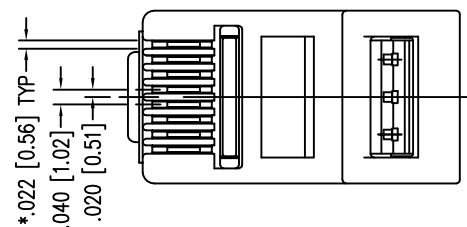

NOTES:

- 1- PLUG KIT CONSISTS OF :  
PRE-INSERTED PLUG HOUSING  
MANAGEMENT BAR
- 2- MATERIALS :  
FRONT HOUSING PLASTIC : CLEAR POLYCARBONATE, UL 94-V0  
MANAGEMENT BAR : CLEAR POLYCARBONATE, UL 94-V0  
CONTACTS : PHOSPHOR BRONZE, SELECTIVE GOLD PLATING
- 3- CONTACTS TERMINATE STRANDED CONDUCTORS UP TO .037 [0.94] OUTSIDE DIAMETER OF INSULATION.
- 4- FOR PRODUCT SPECIFICATION SEE PR026-01.
- 5- DIMENSIONS AND TOLERANCES COMPLY WITH TIA-1096 STANDARD.
- 6- TERMINATED PLUG HEIGHT: .237 [6.02] ±.005 [0.13]

|         |                                   |                        |
|---------|-----------------------------------|------------------------|
| BULK    | 50 MICRO-INCHES [1.27um]          | 937-SP-3088-2PC-F-A192 |
| BULK    | 50 MICRO-INCHES [1.27um]          | 937-SP-3088-2PC-A192   |
| PACKAGE | CONTACT PLATING<br>IN MATING AREA | PART NUMBER            |

THIRD ANGLE PROJECTION

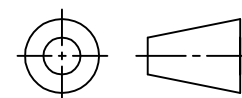

1118 Susquehanna Trail South  
Glen Rock, PA 17327-9199  
(717) 235-7512

<http://www.stewartconnector.com>

DO NOT SCALE DRAWING  
DRAWING IS SUBJECT TO  
CHANGE WITHOUT NOTICE

TITLE: EIGHT CONDUCTOR/EIGHT POSITION LINE CORD MODULE;

DIMENSIONS: INCHES [METRIC]  
UNLESS OTHERWISE SPECIFIED  
TOLERANCES ARE ±.005 [0.13]  
ANGLES ARE ± 1°

THIS DRAWING AND THE SUBJECT MATTER SHOWN THEREON ARE CONFIDENTIAL AND THE PROPRIETARY PROPERTY OF STEWART CONNECTOR AND SHALL NOT BE REPRODUCED, COPIED, OR USED IN ANY MANNER WITHOUT PRIOR WRITTEN CONSENT OF STEWART CONNECTOR. ONE OR MORE U.S. PATENTS MAY APPLY TO THIS PRODUCT. FOR DETAILS, PLEASE VISIT: [HTTP://BELFUSE.COM/STEWART/STEWART\\_PATENTS/](http://BELFUSE.COM/STEWART/STEWART_PATENTS/)

DRN BY: KRL DATE 1/31/06

APPD BY: JM DATE 2-1-06

DWG NO. CT300110 REV. A3

SHEET NO. 1 OF 1

