

PART NUMBER	LENGTH (METERS)	TOLERANCE (METERS)	PART NUMBER	LENGTH (METERS)	TOLERANCE (METERS)
106410-1001	1*	+0.1/-0.0	106410-1021	21	+1.0/-0.0
106410-1002	2*	+0.2/-0.0	106410-1025	25	+1.0/-0.0
106410-1003	3*	+0.3/-0.0	106410-1026	26	+1.0/-0.0
106410-1004	4	+0.4/-0.0	106410-1027	27	+1.0/-0.0
106410-1005	5	+0.5/-0.0	106410-1028	28	+1.0/-0.0
106410-1006	6	+0.6/-0.0	106410-1029	29	+1.0/-0.0
106410-1007	7	+0.7/-0.0	106410-1030	30	+1.0/-0.0
106410-1008	8	+0.8/-0.0	106410-1031	31	+1.0/-0.0
106410-1009	9	+0.9/-0.0	106410-1034	34	+1.0/-0.0
106410-1010	10	+1.0/-0.0	106410-1050	50	+1.0/-0.0
106410-1011	11	+1.0/-0.0	106410-1070	70	+1.0/-0.0
106410-1012	12	+1.0/-0.0	106410-1075	75	+1.0/-0.0
106410-1013	13	+1.0/-0.0	106410-1100	100	+1.0/-0.0
106410-1014	14	+1.0/-0.0	106410-1150	150	+1.0/-0.0
106410-1015	15	+1.0/-0.0	106410-1180	180	+1.0/-0.0
106410-1016	16	+1.0/-0.0	106410-1200	200	+1.0/-0.0
106410-1017	17	+1.0/-0.0	106410-1250	250	+1.0/-0.0
106410-1018	18	+1.0/-0.0	106410-1300	300	+1.0/-0.0
106410-1019	19	+1.0/-0.0	106410-1500	500	+1.0/-0.0
106410-1020	20	+1.0/-0.0			

* FOR CABLES 3 METERS OR LESS, ONE SPLICE PROTECTOR LOCATED APPROXIMATELY IN THE MIDDLE OF CABLE MAY BE USED.

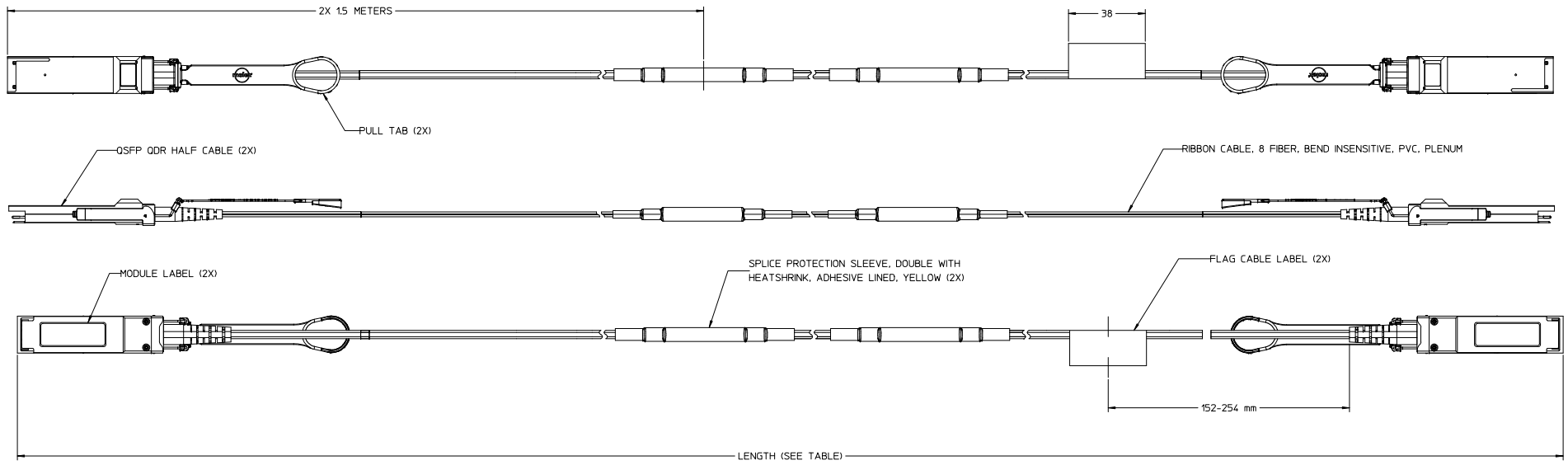

- NOTES:
- MODULES MEET SFF-8436 SPECIFICATION COMPLIANT TO EU DIRECTIVE 2002/95/EC - RoHS 6/6 (EU RoHS - NO EXEMPTIONS ALLOWED).
 - MATERIALS:
 - HOUSINGS: ZINC DIE CAST WITH NICKEL PLATING
 - RELEASE MECHANISM: STAINLESS STEEL SLIDE/WIRE HANDLE WITH PULL TAB
 - PCB FINISH: ENIG
 - ELECTROLESS Ni: 0.005MM - 0.0063 MM (200 - 250 MICRONS)
 - ELECTROLESS Pd-Ni: 0.0003MM-0.0005MM (12 - 20 MICRONS)
 - IMMERSION Au: 0.00003MM-0.00015MM (1-6 MICRONS)
 - SCREWS: STAINLESS STEEL
 - CABLE:
 - TYPE: PLENUM (OFNP) WITH 8 CHANNEL SINGLE-MODE RIBBON
 - COLOR: YELLOW
 - DIAMETER: 4.1MM WIDTH X 2.5MM HEIGHT
 - MINIMUM BEND RADIUS: 25MM
 - CABLE MARKING: CABLE P/N, REVISION, TYPE (OFNP), ROHS, LOT#, METER MARK

ENTER DESCRIPTION EC NO: MF2012-0196 DRAWN BY: EEFUNG CHKD: CHKD APPROVED BY: APPROVED BY DATE: 2011/10/06 DATE: 2011/10/13	QUALITY SYMBOLS ∇=0 ∇=0 ∇=0	GENERAL TOLERANCES (UNLESS SPECIFIED)		DIMENSION STYLE MM ONLY	SCALE 1:1	DESIGN UNITS INCH	THIRD ANGLE PROJECTION
		4 PLACES ± mm ± INCH 3 PLACES ± mm ± INCH 2 PLACES ± mm ± INCH 1 PLACE ± mm ± INCH	DRAWN BY: EEFUNG DATE: 2011/09/21 CHECKED BY: DATE:	TITLE QSFP QDR CABLE			
		ANGULAR ±1/2°	APPROVED BY: DATE:	MOLEX INCORPORATED			
		DRAFT WHERE APPLICABLE MUST REMAIN WITHIN DIMENSIONS	MATERIAL NO: SEE TABLE DOCUMENT NO: SD-106410-1001	SHEET NO: 1 OF 2			

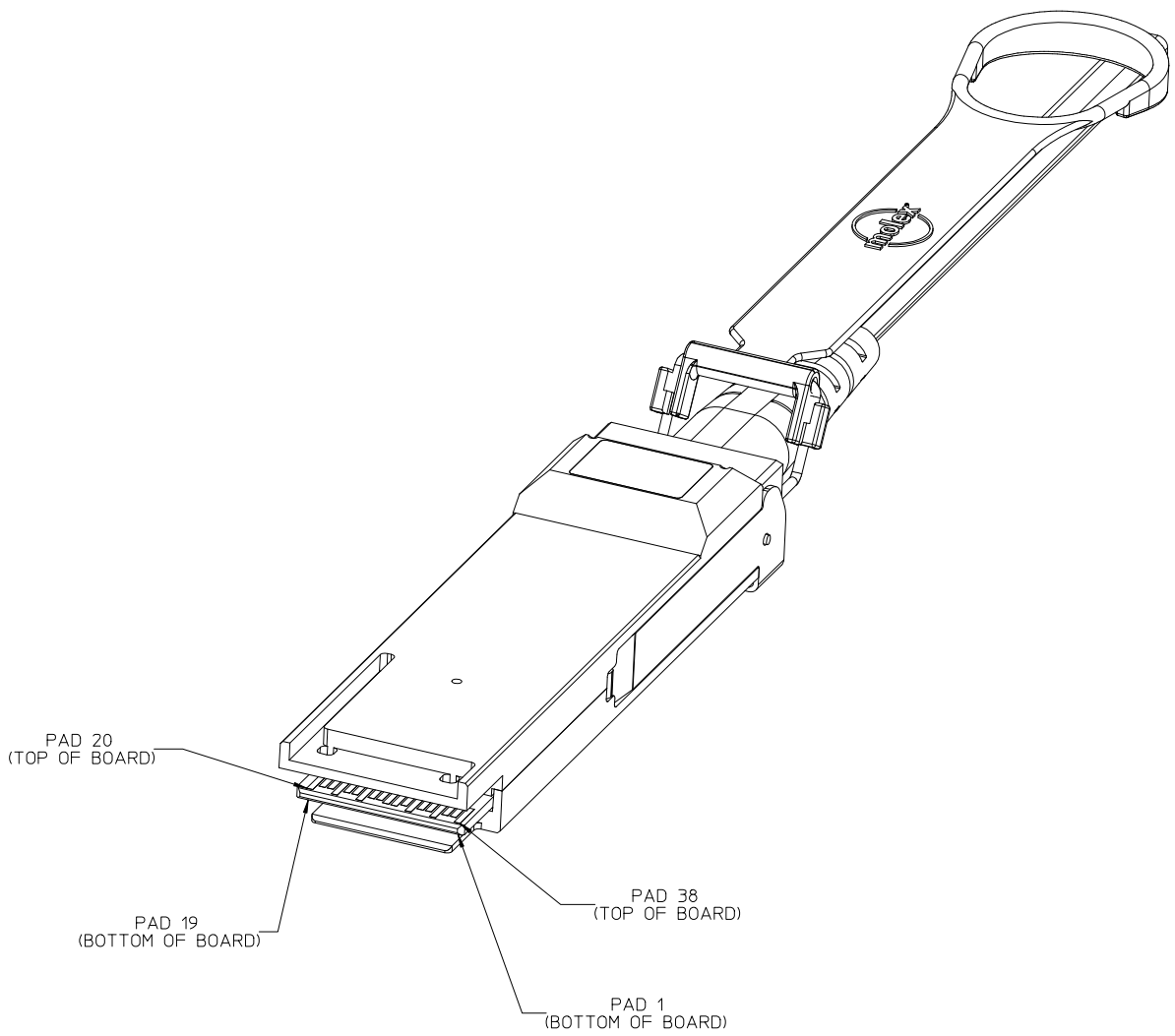

BOTTOM CONTACTS		TOP CONTACTS	
PCB PAD NO.	FUNCTION	PCB PAD NO.	FUNCTION
1	GND	20	GND
2	Tx2n	21	Rx2n
3	Tx2p	22	Rx2p
4	GND	23	GND
5	Tx4n	24	Rx4n
6	Tx4p	25	Rx4p
7	GND	26	GND
8	ModSelL	27	ModPrsL
9	ResetL	28	InTL
10	Vcc Rx	29	Vcc Tx
11	SCL	30	Vcc1
12	SDA	31	LPMode
13	GND	32	GND
14	Rx3p	33	Tx3p
15	Rx3n	34	Tx3n
16	GND	35	GND
17	Rx1p	36	Tx1p
18	Rx1n	37	Tx1n
19	GND	38	GND

PAD 20
(TOP OF BOARD)

PAD 19
(BOTTOM OF BOARD)

PAD 38
(TOP OF BOARD)

PAD 1
(BOTTOM OF BOARD)

ENTER DESCRIPTION EC NO: MF2012-0196 DRAWN/EEFUNG 2011/10/06 CHKD: APPR: BANDREJ 2011/10/13 REV: C1	QUALITY SYMBOLS ▽=0 ▽=0 ▽=0	GENERAL TOLERANCES (UNLESS SPECIFIED) <table border="1"> <tr><th></th><th>mm</th><th>INCH</th></tr> <tr><td>4 PLACES</td><td>± ---</td><td>± ---</td></tr> <tr><td>3 PLACES</td><td>± ---</td><td>± ---</td></tr> <tr><td>2 PLACES</td><td>± ---</td><td>± ---</td></tr> <tr><td>1 PLACE</td><td>± ---</td><td>± ---</td></tr> </table> ANGULAR ±1/2° DRAFT WHERE APPLICABLE MUST REMAIN WITHIN DIMENSIONS		mm	INCH	4 PLACES	± ---	± ---	3 PLACES	± ---	± ---	2 PLACES	± ---	± ---	1 PLACE	± ---	± ---	DIMENSION STYLE MM ONLY DRAWN BY DATE EEFUNG 2011/09/21 CHECKED BY DATE APPROVED BY DATE	SCALE 1:1 DESIGN UNITS INCH THIRD ANGLE PROJECTION	TITLE QSFP QDR CABLE
		mm	INCH																	
	4 PLACES	± ---	± ---																	
	3 PLACES	± ---	± ---																	
2 PLACES	± ---	± ---																		
1 PLACE	± ---	± ---																		
MATERIAL NO. SEE TABLE		DOCUMENT NO. SD-106410-1001		SHEET NO. 2 OF 2																
THIS DRAWING CONTAINS INFORMATION THAT IS PROPRIETARY TO MOLEX INCORPORATED AND SHOULD NOT BE USED WITHOUT WRITTEN PERMISSION																				
MOLEX INCORPORATED																				