

REVISIONS				
ZONE	REV	DESCRIPTION	DATE	APPROVED

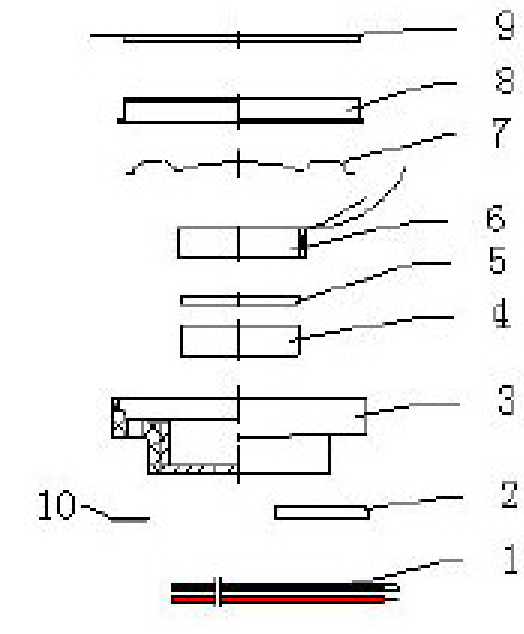

No.	Part Name	Material	Quantity
1	UL1571 AWG32#	Red/Black	2
2	PCB	FR-4	1
3	Frame	PBT	1
4	Magnet	Nd Fe B	1
5	Plate	SPCC	1
6	Voice Coil	Copper	1
7	Membrane	PEN	1
8	Cap	SUS303	1
9	Gasket	Black Net	1
10	Screen	Black Cloth	1

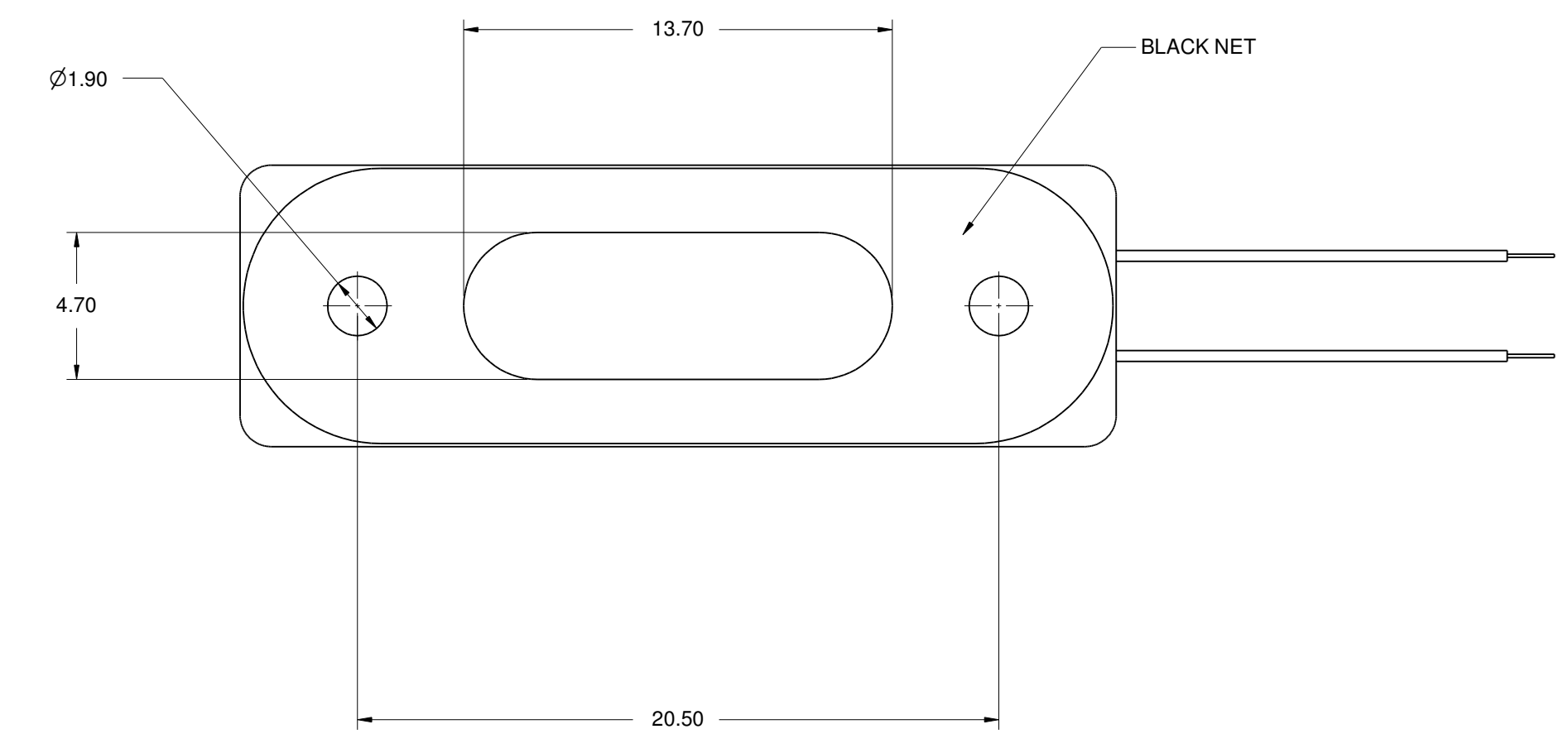
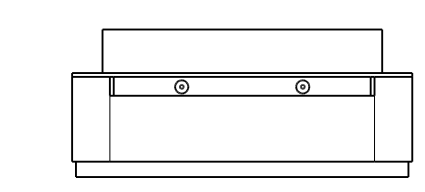
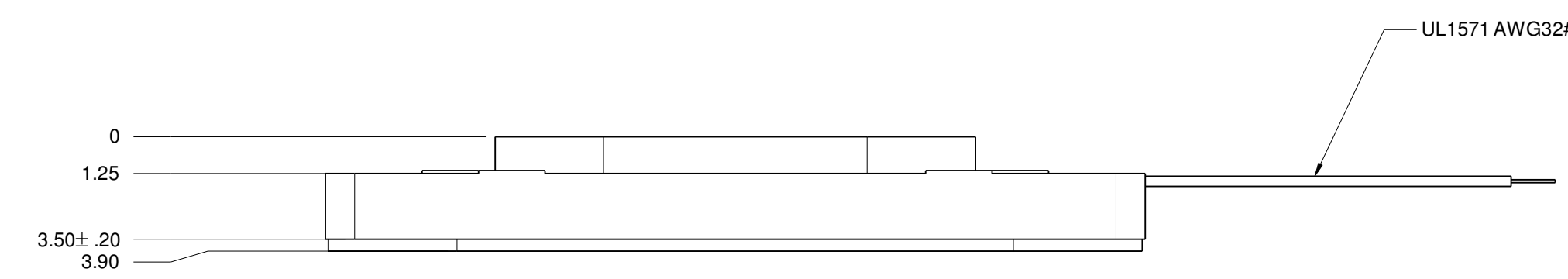
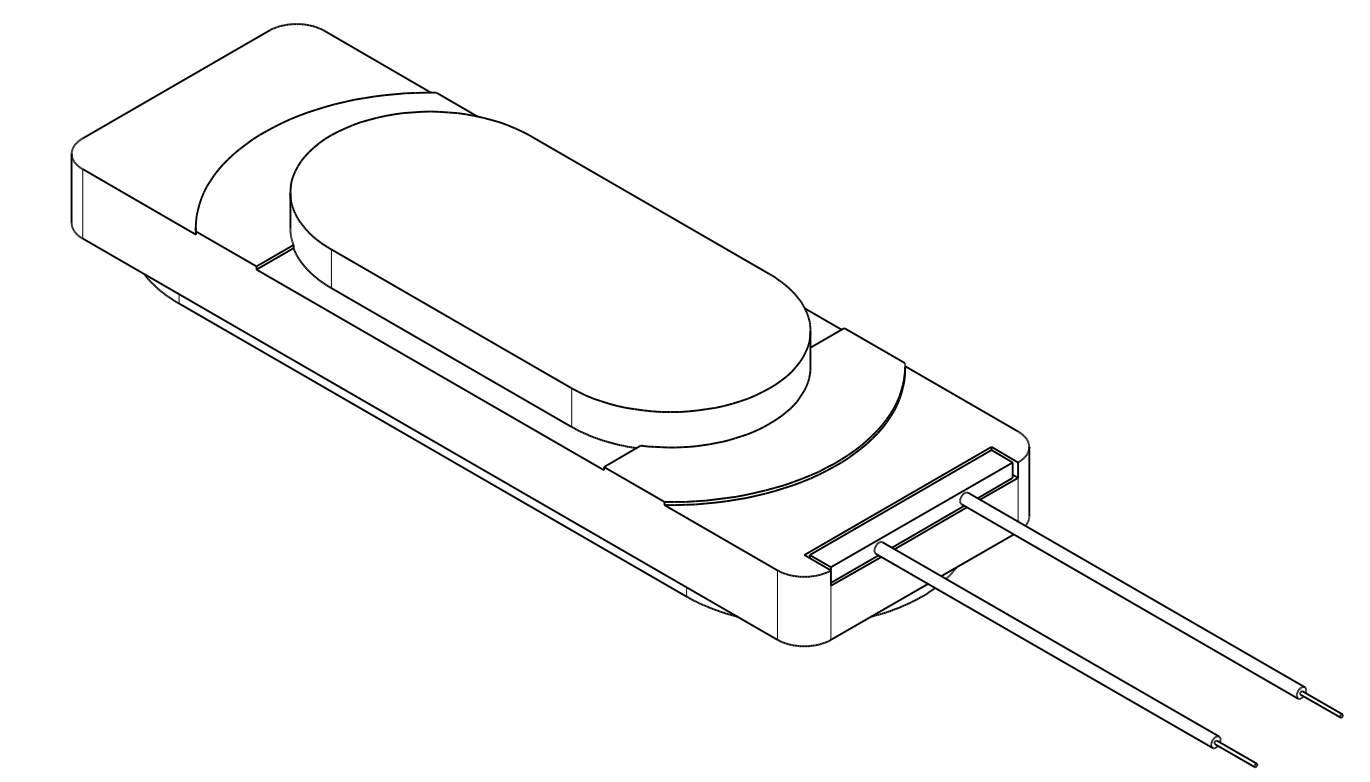
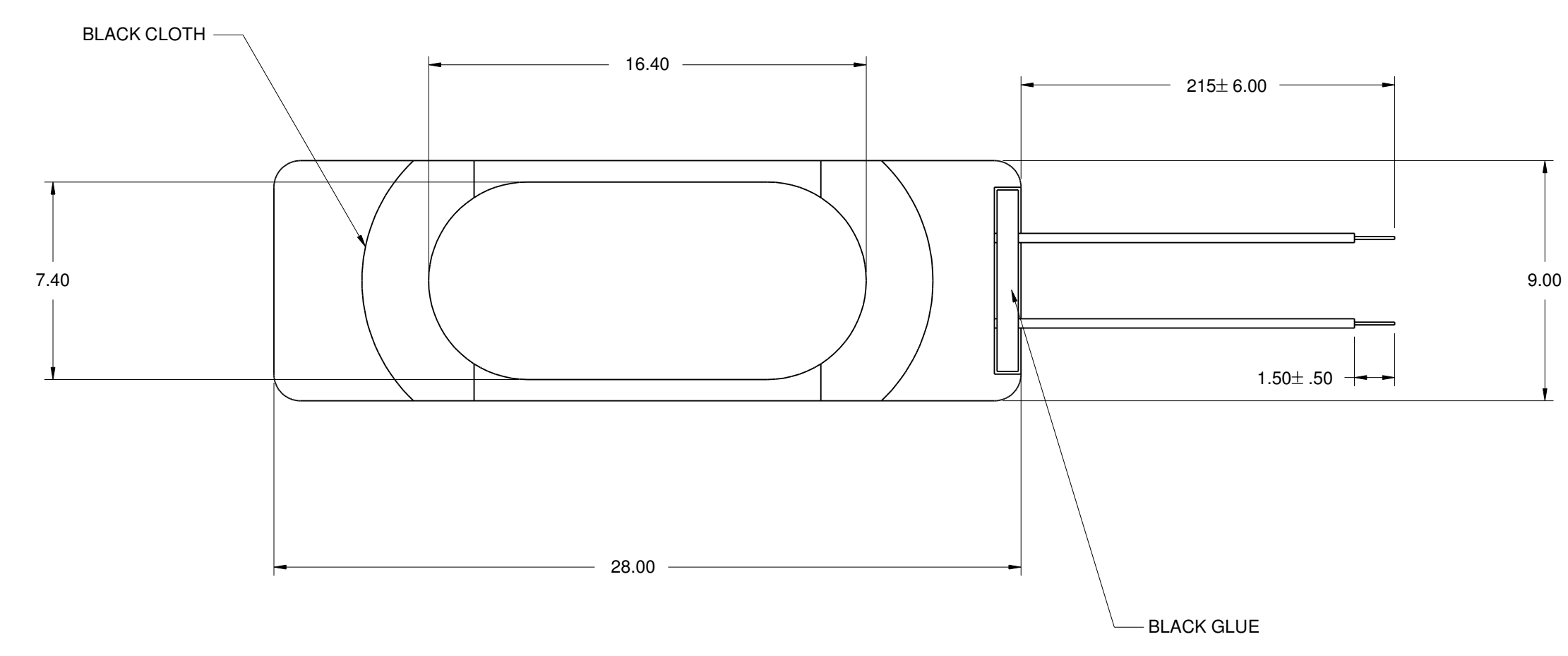

TOLERANCE +/- 0.5MM UNLESS NOTED



SIZE D	FSCM NO.	DWG NO. sp-2809	REV
SCALE 1:1	SHEET 1 OF 1		